

SKG123N系列规格书 L1+L5双频定位模块 SKG123N Series Datasheet L1+L5 Dual-band Positioning Module

文档信息/Document information

标题/Title	SKG123N L1+L5 双频定位模块规格书	
	SKG123N L1+L5 Dual-band Positioning Module Datasheet	
文档类型/Document type	规格书/Datasheet	
文档编号/Document number	SL-22120306	
修订和日期/Revision and date	V1.01	9-Jan-2023
公开限制/Disclosure restriction	公开/Public	

版本历史/Revision History

版本/Version	描述/Description	制定/Make	日期/Date
V1.01	初始版本/Initial version	George	20230110

SKYLAB 保留本文档及本文档所包含的信息的所有权利。SKYLAB 拥有本文档所述的产品、名称、标识和设计的全部知识产权。严禁没有征得 SKYLAB 的许可的情况下复制、使用、修改或向第三方披露本文档的全部或部分内容。

SKYLAB 对本文档所包含的信息的使用不承担任何责任。没有明示或暗示的保证，包括但不限于关于信息的准确性、正确性、可靠性和适用性。SKYLAB 可以随时修订这个文档。可以访问 www.skylab.com.cn 获得最新的文件。

Copyright © 2023, 深圳市天工测控技术有限公司。

SKYLAB® 是深圳市天工测控技术有限公司在中国的注册商标。

SKYLAB reserves all rights to this document and the information contained herein. Products, names, logos and designs described herein may in whole or in part be subject to intellectual property rights. Reproduction, use, modification or disclosure to third parties of this document or any part thereof without the express permission of SKYLAB is strictly prohibited.

The information contained herein is provided "as is" and SKYLAB assumes no liability for the use of the information. No warranty, either express or implied, is given, including but not limited, with respect to the accuracy, correctness, reliability and fitness for a particular purpose of the information. This document may be revised by SKYLAB at any time. For most recent documents, visit www.skylab.com.cn.

Copyright © 2023, Skylab M&C Technology Co., Ltd.

SKYLAB® is a registered trademark of Skylab M&C Technology Co., Ltd in China

目录/Contents

1 产品简介/Product Introduction	4
2 典型应用/Applications	5
3 产品特点/Features	5
4 高级特性/ Advanced features	6
AGNSS Support for Fast TTFF (EPO™)	6
EASY™	6
RTK- Real - time kinematic	6
DR- Dead Reckoning	7
授时/ Timing	7
AIC_Multi-tone active interference canceller	7
5 传输及外设接口/Transmission and peripheral interface	8
5.1 PPS	8
5.2 UART	8
5.3 通信频率/Frequency of communication	8
5.4 通信协议/Communication protocol	8
5.5 控制命令/Control command	9
6 电气特性/Electrical specification	9
7 性能指标/Performance evaluation	11
8 管脚定义/PIN Definition	13
9 管脚描述/Pin description	14
10 机械尺寸/Machine Dimension	15
11 参考电路/Reference circuit	16
12 软件说明/ Software description	16
12.1 NMEA 0183 协议/ The NMEA 0183 protocol is available	16
12.2 GGA-定位数据信息/GGA- Location information	17
12.3 GSA-当前卫星信息/GSA- GNSS satellites in using	18
12.4 GSV-可见卫星信息//GSV-GNSS Satellites in View	19
12.5 RMC-推荐定位信息/ RMC-Recommended Minimum locating information	20
12.6 GLL-地理定位信息/Geographic Position – Latitude/Longitude	21
12.7 VTG-地面速度信息/VTG-Course Over Ground and Ground Speed	22
12.8 ZDA-时间日期信息/ ZDA-Date and Time	23
13 联系方式/ Contact Information	23

1 产品简介/Product Introduction

SKG123N 系列模块包括 SKG123N、SKG123ND、SKG123NT、SKG123NR 和 SKG123NRD，是一款 L1+L5 双频段、高精度、高性能的 GNSS 领域定位模块，模块能够同时支持 GPS、BDS、GLONASS、Galileo 以及 QZSS 的卫星定位系统、并且支持 AGPS；集成了高性能、高可靠性的定位引擎，可实现快速精确的 GNSS 定位。

SKG123N Series modules include SKG123N, SKG123ND, SKG123NT, SKG123NR and SKG123NRD, is a L1 + L5 dual band, high precision, high performance GNSS field positioning module, module can support GPS, BDS, GLONASS, Galileo and QZSS satellite positioning system, and support AGPS; integrated high performance, high reliability positioning engine, can achieve fast and accurate GNSS positioning.

SKG123N 提供常规 GNSS 高精度定位，可实现米级定位服务。

SKG123N Provide conventional GNSS high-precision positioning, which can realize meter-level positioning service.

SKG123ND 提供常规 GNSS 高精度定位和惯导定位服务，模块集成了 6 轴 IMU 并支持 DR 算法，可融合 6 轴 IMU 数据和 GNSS 原始数据，确保模块即便在 GNSS 信号不存在或信号较弱的情况下也能发挥优越的定位性能。

SKG123ND Provide conventional GNSS high-precision positioning and inertial navigation positioning services. The module integrates 6-axis IMU and supports DR algorithm, which can integrate 6-axis IMU data and GNSS raw data to ensure that the module can perform superior positioning performance even when the GNSS signal does not exist or the signal is weak.

SKG12NT 提供常规 GNSS 高精度定位和授时服务，实现高精度授时。

SKG12NT Provide conventional GNSS high-precision positioning and timing services to achieve high-precision timing.

SKG123NR 提供 RTK 相位差分高精度定位，定位精度可达 10cm，实现厘米级定位。

SKG123NR Provide RTK phase difference high precision positioning, positioning accuracy can reach 10cm, to achieve centimeter-level positioning.

SKG123NRD 提供 RTK 相位差分高精度定位和惯导定位服务，实现厘米级和惯导定位。

SKG123NRD Provide RTK phase difference high-precision positioning and inertial navigation positioning services, to achieve centimeter-level and inertial navigation positioning.



图 1: SKG123N 正视图/Top view

2 典型应用/Applications

- ◆ 汽车导航/ Auto navigation
- ◆ 车辆高精度 RTK 导航/ High precision RTK navigation
- ◆ 车辆惯性导航/ Vehicle inertial navigation
- ◆ RTK 高精度定位应用/ High-precision localization of the RTK is used
- ◆ 授时应用/ Time application
- ◆ 车辆远程监控/ Remote vehicle monitoring

3 产品特点/Features

- ◆ L1 支持 GPS, GLO, GAL, BDS, QZSS 系统/ L1 supports GPS, GLO, GAL, BDS, QZSS systems
- ◆ L5 支持 GPS, GAL, BDS, QZSS/ L5 supports GPS, GAL, BDS, and QZSS
- ◆ 支持 SBAS(WAAS, EGNOS, MSAS, GAGAN)/ Support SBAS(WAAS, EGNOS, MSAS, GAGAN)
- ◆ 支持 RTCM(v2.3 和 v3.3)/ Support RTCM(v2.3 和 v3.3)
- ◆ 标准通信协议 NEMA0183/Plug and play standard communication protocol NEMA0183
- ◆ 支持 AGPS: EPO, EASY, NVRAM, hotstill/ Support AGPS: EPO, EASY, NVRAM, hotstil
- ◆ 极快的 TTFF: 冷启动 <28s (CTTFF is 24s with GLO); 热启动 <1s/ TTFF: cold start <28s (CTTFF is 24s with GLO); hot start <1s
- ◆ 弱信号下具有较好的定位精度和位置有效性/ It has better positioning accuracy and location effectiveness under weak signals
- ◆ 符合 RoHS, FCC, CE /Compliance with RoHS, FCC, CE

4 高级特性/ Advanced features

AGNSS Support for Fast TTFF (EPO™)

AGNSS (EPO™) 提供预测扩展预测轨道数据以加速 TTFF，用户可以通过互联网或无线网络从 FTP 服务器下载到 GNSS 引擎，当卫星导航信息不足或弱信号区时，GNSS 引擎将使用 EPO 数据协助位置计算。

The AGNSS (EPO™) supply the predicated Extended Prediction Orbit data to speed TTFF, users can download the EPO data to GNSS engine from the FTP server by internet or wireless network, the GNSS engine will use the EPO data to assist position calculation when the navigation information of satellites are not enough or weak signal zone.

EASY™

EASY™是嵌入式的，用于快速定位的辅助系统。通电时 GNSS 引擎将自动计算和预测单个环境（最长达 3 天），并将预测信息保存到内存中，如果没有足够的卫星信息，GNSS 引擎将使用这些信息进行定位，因此该功能将有助于在室内或城市条件下的定位和 TTFF 改进。备份电源（VBACKUP）是必要的。

The EASY™ is embedded assist system for quick positioning, the GNSS engine will calculate and predict automatically the single emperies (Max. up to 3 days) when power on, and save the predict information into the memory, GNSS engine will use these information for positioning if no enough information from satellites, so the function will be helpful for positioning and TTFF improvement under indoor or urban condition, the Backup power (VBACKUP) is necessary.

RTK- Real - time kinematic

SKG123NR 和 SKG123NRD 支持 RTK 功能。为支持 RTK 功能，该模块需要通过 UART 接口接收 RTK 校正信息。RTK 校正信息可通过使用一个蜂窝模块或者其他地面网络技术传送。默认配置下，模块将基于接收到的校正数据尝试实现最优的定位精度。

SKG123NR and SKG123NRD support the RTK function. To support the RTK function, the module needs to receive the RTK correction information through the UART interface. RTK correction information can be transmitted using a cellular module or other terrestrial network technology. Under the default configuration, the module tries to achieve the optimal positioning accuracy based on the received correction data.

当模块接收到一条 RTCM 信息流时，将进入 RTK 浮点模式。一旦载波相位模糊度确定，模块进入 RTK 固定模式。RTK 固定模式下，模块可实现厘米级高精度定位。

When the module receives an RTCM information flow, it enters the RTK floating point mode. Once the carrier phase ambiguity is determined, the module enters the RTK fixed mode. In the RTK fixed mode, the module can achieve high-precision positioning at the centimeter-level.

通常在 60 秒内，移动站就能够确定载波模糊度并从 RTK 浮点模式切换到 RTK 固定模式。该时间间隔称为收敛时间。

Usually within 60 seconds, the mobile station is able to determine the carrier ambiguity and switch from RTK floating point mode to RTK fixed mode. The time interval called the convergence time.

DR- Dead Reckoning

SKG123ND 和 SKG123NRD 模块支持 DR 功能。模块可将卫星导航数据与车轮速度、陀螺仪和加速度计信息相结合，因此在车辆状态（如速度、前进方向或垂直位移）发生变化，甚至在卫星信号部分或完全受阻的情况下，仍能够在诸如隧道、城市峡谷等弱信号环境中实现连续、高精度的定位。详细信息见文档《SkyLab_SKG123ND_规格书 datasheet》。

The SKG123ND and SKG123NRD modules support the DR function. Module can combine satellite navigation data and wheel speed, gyroscope and accelerometer information, so that the vehicle state changes (such as speed, forward direction or vertical displacement), even the case of satellite signal partially or completely blocked, It can still achieve continuous and high-precision positioning in weak signal environments such as tunnels and urban canyons. See the details in the document 《SkyLab_SKG123ND_规格书 datasheet》.

授时/ Timing

SKG123NT 支持授时功能。提供 1PPS（1Pulse Per Second）秒脉冲信号和高达 10Hz 的 PVT 信息输出。详细信息见文档《SkyLab_SKG123NT_规格书 datasheet》。

SKG123NT Support the timing function. Provide 1 PPS (1Pulse Per Second) second pulse signal and PVT information output up to 10Hz. For details, see the document 《SkyLab_SKG123NT_规格书 datasheet》.

AIC_Multi-tone active interference canceller

由于导航系统集成了不同的应用（Wi-Fi、GSM/GPRS、3G/4G、蓝牙），射频信号的谐波会影响 GPS 的接收。多音调有源干扰消除器可以抑制来自主板上其他有源部件的外部射频干扰，在不改变设计硬件的情况下提高 GPS 接收能力。SKG123N 可以抵消多达 12 个独立的信道干扰连续波。

Because different application (Wi-Fi , GSM/GPRS,3G/4G,Bluetooth) are integrated into navigation system , the harmonic of RF signal will influence the GPS reception. The multi- tone active-interference canceller can reject external RF interference which come from other active components on the main board, to improve the capacity of GPS reception without any needed HW change in the design. SKG123N can cancel up to 12 independent channel interference continuous wave.

5 传输及外设接口/Transmission and peripheral interface

5.1 PPS

秒脉冲（PPS）：SKG123N 提供非常精准的时间脉冲 PPS 信号，PPS 信号可为外部系统提供授时功能，脉冲宽度可调，精度 15ns 每 24h，默认情况下每秒输出一个脉冲。

Second pulse (PPS): The SKG123N provides a very accurate time pulse PPS signal, the PPS signal can provide the timing function for the external system, the pulse width is adjustable, the accuracy is 15ns every 24h, by default, it output a pulse per second.

5.2 UART

SKG123N 模块提供了两个串口，其中，UART0 用于发送卫星信息和接收差分信息，UART2 用于输入、输出差分信息。支持数据传输、固件升级功能，输入/输出信号类型为 LVTTTL 电平。默认波特率为 115200bps，最高可设为 921600bps，串口波特率均可由用户自行配置。

The SKG123N module provides two serial ports. Serial UART0 is used to send satellite information and receive differential information, and serial port 2 is used to input and output differential information. Support data transmission, firmware upgrade function, input / output signal type is LVTTTL level. The default port rate is 115200bps, which can be set up to 921600bps, and the serial port port rate can be configured by the user.

5.3 通信频率/Frequency of communication

目前，系统支持输出 1hz 和 10hz 的数据刷新频率，默认频率为 1HZ。

Currently, the system supports the output data refresh frequency of 1hz and 10hz. The default frequency is 1hz.

5.4 通信协议/Communication protocol

目前，SKG123N 模块输出常见的 NMEA0183 协议，例如：GPGGA、GPRMC，GPGSV，GPGSA。

At present, THE SKG123N module outputs common NMEA0183 protocols, such as GPGGA, GPRMC, GPGSV and GPGSA.

5.5 控制命令/Control command

SKG123N 系统支持用户通过串口发控制命令实现如下功能，但是，SKG123N 无法保存设置，即 SKG123N 每次上电都是按默认方式输出。

The SKG123N system supports the following functions by sending control commands through the serial port.

However, the SKG123N cannot save the Settings. That is, the SKG123N output the default mode every time it is powered on.

6 电气特性/Electrical specification

◆ 极限参数/limit Parameter

参数/Parameter	符号/Symbol	最小值/Min.	最大值/Max.	单位/Unit
电源/power supply				
供电电压/Supply Voltage	VCC	-0.3	3.6	V
输入输出/ IO				
I/O 特性/I/O Features	VIO	-0.3	3.6	V
RF 输入功率/RF Input power	RF_IN		0	dBm
静电保护/ESD	RF_IN		2000	V
环境/Environment				
存储温度/Storage temperature	Tstg	-40	85	° C
湿度/Humidity			95	%

◆ 电气特性/Electrical specification

参数/Parameter	符号/Symbol	条件/Condition	最小值/Min.	典型值/Type	最大值/Max.	单位/Unit
电源电压/Supply voltage	VCC		3.0	3.3	3.6	V
电源电压/Supply voltage	V_BCKP		2.2	3.3	3.6	V

输入高压/input high voltage	VIH		2.4		3.6	V
输入低压/input low voltage	VIL		0		0.6	V
输出高压/output high voltage	VOH	Ioh=4mA	2.8			V
输出低压/output low voltage	VOL	Iol=4mA			0.4	V
工作温度 /Operating temperature	Topr		-40		85	°C

注：本产品内部有复杂的组合导航算法，所以功耗比一般的导航模块高，请在设计硬件电路过程中，一定给本产品预留足够的功耗，即电流不小于 150mA。

Note: This product has a complex integrated navigation algorithm, so the power consumption is higher than that of ordinary navigation modules. Please reserve enough power consumption for this product during the design of hardware circuit, that is, the current is not less than 150mA.

V_BCKP 注意事项/ V_BCKP Considerations:

1. V_BCKP 电压不可低于推荐工作电压的最小值，否则模块无法正常工作。
1. The V_BCKP voltage shall not be lower than the minimum value of the recommended operating voltage, otherwise the module cannot work normally.
2. 在 Continuous 模式下，V_BCKP 最大耗流为 100 μA，这将使电池逐渐耗尽，因此不推荐使用不可充电电池。
2. In Continuous mode, the maximum flow consumption of V_BCKP is 100 μA, which will gradually exhaust the battery, so it is not recommended Electric battery.
3. 请根据电池的充电电流选择合适的电阻。
3. Select the appropriate resistance according to the charging current of the battery.
4. 建议通过 MCU 来控制模块的 V_BCKP，以便在模块进入异常状态时重新启动模块。
4. It is recommended that the V_BCKP of the module be controlled through the MCU to restart the module when the module enters an abnormal state.

7 性能指标/Performance evaluation

表 1: 产品特性/ Table 1: Product Characteristics

特性/Characteristic		SKG123N	SKG123ND	SKG123NT	SKG123NR	SKG123NRD	
等级	工规	●	●	●	●	●	
	车规	-	-	-	-	-	
种类	标准精度 GNSS	●	●	●	-	-	
	授时	-	-	●	-	-	
	DR	-	●	-	-	●	
	RTK	-	-	-	●	●	
通信接口	UART	●	●	●	●	●	
	SPI	-	-	-	-	-	
	I2C	●	●	●	●	●	
集成特性	前端双频 LNA	●	●	●	●	●	
	前端双频滤波器	●	●	●	●	●	
	6 轴 IMU	-	●	-	-	●	
星系	GPS	L1C/A	●	●	●	●	●
		L5	●	●	●	●	●
		L2C	-	-	-	-	-
	GLONASS	L1	●	●	●	-	●
		L2	-	-	-	-	-
	Galileo	E1	●	●	●	●	●
		E5a	●	●	●	●	●
		E5b	-	-	-	-	-
	BDS	B1I	●	●	●	●	●
		B2a	●	●	●	●	●
		B2I	-	-	-	-	-
	QZSS	L1C/A	●	●	●	-	●

		L5	●	●	●		●	
		L2C	-	-	-	-	-	
	IRNSS	L5	-	-	-	-	-	
	SBAS	L1	●	●	-	-	-	
温度范围		工作温度范围: -40 ° C 至+85 ° C						
		存储温度范围: -40 ° C 至+90 ° C						
物理特性		尺寸: (12.2 ±0.15) mm ×(16.3±0.3) mm ×(2.4 ±0.20) mm						
		重量: 约 0.9 g						

表 2: 产品性能/ Table 2: Product performance

参数	规格	SKG123N	SKG123ND	SKG123NT	SKG123NR	SKG123NRD
功耗 ¹ (GPS+ GLONASS+ Galileo+BDS +QZSS)	捕获	46mA	66mA	46mA	48mA	待定
	跟踪	44mA	69mA (INS)	44mA	58mA(RTK)	待定
	Backup 模 式	25µA	25µA	25µA	25µA	待定
灵敏 (GPS+ GLONASS+ Galileo+BDS +QZSS)	捕获	-147dBm	-145dBm	-145dBm	-145dBm	待定
	重捕获	-159dBm	-157dBm	-157dBm	-157dBm	待定
	跟踪	-165dBm	-165dBm	-165dBm	-165dBm	待定
TTF (AGNSS 关闭) ¹	完全冷启动	26s	26s	26s	26s	待定
	温启动	16s	16s	16s	16s	待定
	热启动	1s	1s	1s	1s	待定
TTFF (EASY 开启) ²	完全冷启动	16s	16s	16s	-	-
	温启动	2s	2s	2s	-	-
	热启动	1s	1s	1s	-	-
TTFF (EPO 开启) ²	完全冷启动	5s	5s	5s	-	待定
	温启动	3s	3s	3s	-	待定
	热启动	1s	1s	1s	-	待定

水平定位精度	自主: 1.2m	自主: 1.2m	自主: 1.2m	自主: 1.2m RTK: 2cm+ 1ppm	自主: 1.2m RTK: 1cm+ 1ppm
收敛时间	-		-	RTK: <10s	RTK4: 待定
更新频率	PVT: 1~10 Hz GNSS 原始 数据: 1 Hz	PVT: 1 Hz/10 Hz GNSS 原始数 据: 1 Hz	PVT: 1 Hz/10 Hz GNSS 原始数 据: 10 Hz	PVT: 1 Hz (RTK) GNSS 原始数 据: 1 Hz	PVT: 待定 (RTK) GNSS 原始数 据: 1Hz
1PPS 精度 ¹	20ns	20ns	2ns	20ns	20ns
速度精度 ¹	0.2 m/s	0.05 m/s	0.2 m/s	0.05 m/s	0.2 m/s
动态性能 ¹	最大高度: 10000 m 最大速度: 500 m/s 最大加速度: 4g				

8 管脚定义/PIN Definition

1	SCL	GND	24
2	SDA	VCC_IN	23
3	GPIO10	VBAT_VRTC	22
4	EFUSE	UART0_RXD	21
5	UART2_RTS	UART0_TXD	20
6	UART2_CTS	UART2_RXD	19
7	VIO18	UART2_TXD	18
8	CHIP_EN	UART1_RXD	17
9	VCC_RF	UART1_TXD	16
10	GND	GPIO26	15
11	RF_IN	LNA_EN	14
12	GND	GND	13

SKG123N
Top view

图 3: SKG123N 管脚定义/pin definitions

9 管脚描述/Pin description

管脚编号 /Pin No.	管脚定义/Pin name	IO	使用说明/Description	电压/Voltage(±5%)
1	SCL	DI	GPIO2; I2C_SCL/I2C 串行时钟	+2.8V
2	SDA	DIO	GPIO3; I2C_SDA/I2C 串行数据	+2.8V
3	GPIO10	DO	GPIO10; PPS 秒脉冲信号输出/Second pulse signal output	+2.8V
4	EFUSE	P_IN	eFuse 供电/eFuse power source	+1.8V
5	UART2_RTS	DO	GPIO0; UART2_RTS	+2.8V
6	UART2_CTS	DI	GPIO1; UART2_CTS	+2.8V
7	VIO18	P_out	DC1.8V Output/1.8V 电源输出	+1.8V
8	CHIP_EN	DI	模块复位, 低电平有效/Module reset, active low	+2.8V
9	VCC_RF	P_out	有源天线供电端输出/Active antenna power output	VCC
10	GND	G	电源地/Ground	GND
11	RF_IN	AI	GNSS 天线接口	/
12	GND	G	电源地/Ground	GND
13	GND	G	电源地/Ground	GND
14	LNA_EN	DO	GPIO32; 外部 LNA 使能输出	+1.8V
15	GPIO26	DIO	GPIO26	+2.8V
16	UART1_TXD	DO	GPIO17; UART1_TXD	+1.8V
17	UART1_RXD	DI	GPIO16; UART1_RXD	+1.8V
18	UART2_TXD	DO	GPIO6; UART2_TXD; 备用串口发送 /Standby serial port transmission	+2.8V
19	UART2_RXD	DI	GPIO5; UART2_RXD; 备用串口接收 /Standby serial port reception	+2.8V
20	UART0_TXD	DO	GPIO7; UART0_TXD; 串口发送/Serial	+2.8V
21	UART0_RXD	DI	GPIO8; UART0_RXD; 串口接收/Serial	+2.8V

22	VBAT_VRTC	P_in	备份电池/Backup battery: 2.2V--3.6V	2.2V--3.6V
23	VCC_IN	P_in	工作电压/Operating voltage: 3.0-3.6V	3.0-3.6V
24	GND	G	电源地/Ground	GND

10 机械尺寸/Machine Dimension

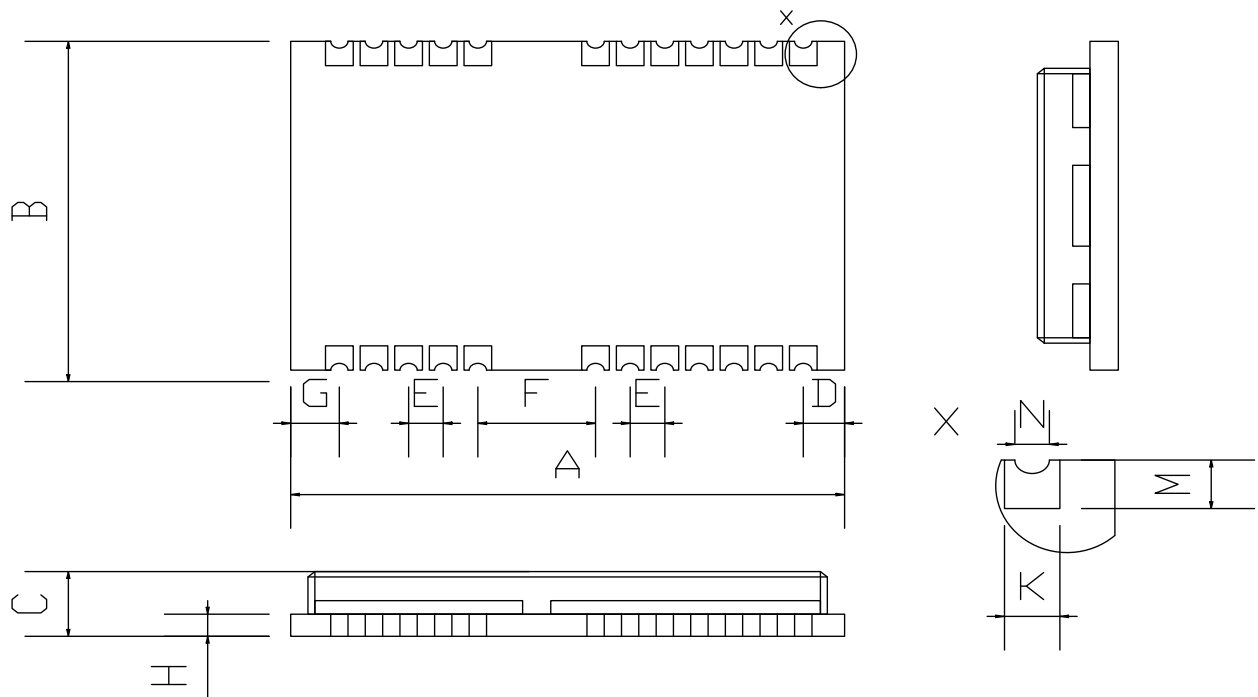

Symbol	Min.(mm)	Type(mm)	Max.(mm)
A	15.9	16.0	16.6
B	12.1	12.2	12.3
C	2.2	2.4	2.6
D	0.9	1.0	1.3
E	1.0	1.1	1.2
F	2.9	3.0	3.1
G	0.9	1.0	1.3
H		0.82	
M	0.7	0.8	0.9
N	0.8	0.9	1.0
K	0.4	0.5	0.6
Weight	1.6g		

图 4: SKG123N 机械尺寸/Machine Dimension

11 参考电路/Reference circuit



图 5: SKG123N 参考电路//Reference circuit

12 软件说明/ Software description

12.1 NMEA 0183 协议/ The NMEA 0183 protocol is available

表 12.1-1 NMEA-0183 输出信息/ Table 10.1-1 NMEA-0183 Output information

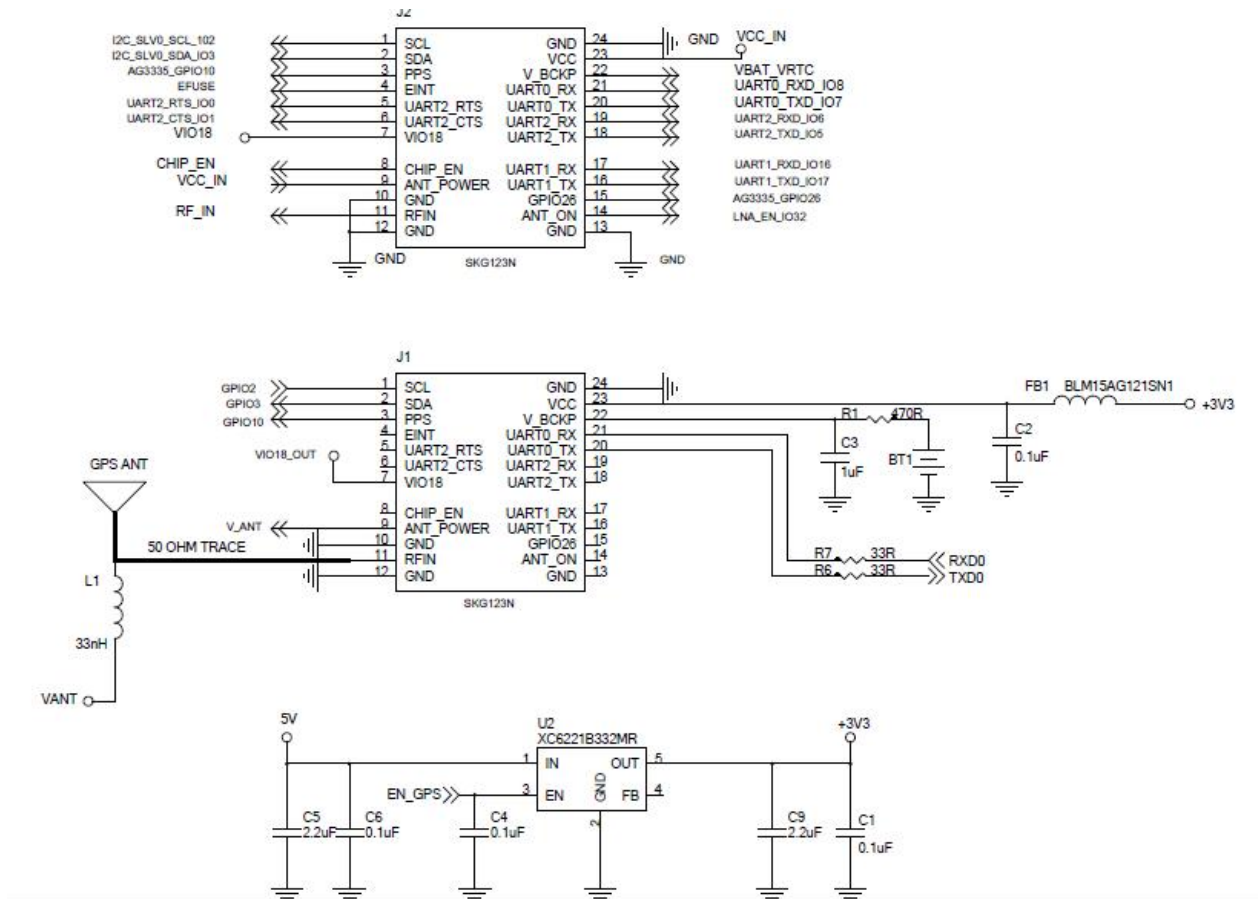
NMEA 协议/NMEA protocol	描述/Description	默认/Default
GGA	定位数据信息/ Global positioning system fixed data	打开/Y
GSA	当前卫星信息/ DOP and active satellites	打开/Y
GSV	可见卫星信息/ Satellites in view	打开/Y
RMC	推荐定位信息/Recommended minimum specific data	打开/Y
GLL	大地坐标信息/Geographic position—latitude/longitude	打开/Y
VTG	地面速度信息/ Course over ground and ground speed	打开/Y
ZDA	当前时间(UTC1)信息/Date and Time	打开/Y

表 12.1-2 标识符助记码/Identifier mnemonic code

标识符/Identifier	数据类型/ Data type
GB	北斗模式/ Beidou mode
GP	GPS 模式/ GPS mode
GN	GNSS 模式/ GNSS mode
GA	Galileo 模式/ Galileo mode
GL	GLONASS 模式/ GLONASS mode

12.2 GGA-定位数据信息/GGA- Location information

此语句包含定位位置、定位时间、定位精度。

Contains the location, time, and precision factor of navigation positioning.

\$GNGGA,022326.000,2238.3443,N,11403.0962,E,1,22,0.72,104.0,M,-2.2,M,,*69

表 12.2-1 GGA 语句格式/GGA Data Format

名称/Name	举例/Example	单位/Units	描述/Description
语句 ID/Message ID	\$GNGGA		表明语句为 GGA 信息/ GGA protocol header
UTC 时间/UTC Position	022326.000		hhmmss.sss 时分秒格式/Time seconds format
纬度/ Latitude	2238.3443		ddmm.mmmm 度分格式/Degree split format
纬度 N/S / N/S indicator	N		N=北纬 S=南纬
经度/ Longitude	11403.0962		dddmm.mmmm 度分格式
经度 E/W / E/W Indicator	E		E=东经 W=西经/ N=north or S=south
定位状态/ Position Fix Indicator	1		见附表 10.2-2/ See Table 10.2-2
已使用卫星数量 /Satellites Used	22		范围 0 到 24/ Range 0 to 12
HDOP 水平精度因子	0.72		
海拔高度/MSL Altitude	104.0	米/M	
单位/Unit	M		
大地水准面高度/ geoidal height	-2.2		
水准面划分单位/Level surface division unit	M	米/M	
校验值/ Checksum	*69		
EOL	<CR> <LF>		结束标志符/ End of message termination

表 12.2-2 定位状态描述/ Position Fix Indicators

数值/Value	描述//Description
0	未定位或定位信息不可用/ Unpositioned or positioned information is not available
1	SPS 模式/ SPS model
2	GNSS, SPS 模式/ GNSS, SPS mode
3	PPS 模式/ PPS model

12.3 GSA-当前卫星信息/GSA- GNSS satellites in using

此条语句包含模块的选定工作模式，定位类型，已使用卫星的 PRN 信息及 PDOP, HDOP, VDOP 等信息。

This statement contains the selected working mode of the module, positioning type, PRN information of used satellites, PDOP, HDOP, VDOP and other information.

\$GNGSA,A,3,199,195,08,26,09,31,16,194,193,27,03,04,1.07,0.72,0.79,1*05

\$GNGSA,A,3,67,66,,,,,,,,,1.07,0.72,0.79,2*0E

\$GNGSA,A,3,,,,,,,,,1.07,0.72,0.79,3*0E

\$GNGSA,A,3,37,20,07,,,,,,,,,1.07,0.72,0.79,4*08

表 12.3-1 GSA 语句格式/GSA Data Format

名称/Name	举例/Example	单位/Units	描述/Description
语句 ID/ Message ID	\$GNGSA		表明语句为 GSA 信息 / Indicates that the statement is GSA information
模式 1/ Mode 1	A		表 10.3-3/ See Table 10.3-3
模式 2/ Mode 2	3		表 10.3-2/ See Table 10.3-2
已使用卫星 ID 信息/ ID of satellite used	199		第一信道的 Sv 信息/Sv on Channel 1
已使用卫星 ID 信息/ ID of satellite used	195		第二信道的 Sv 信息/Sv on Channel 2
...
已使用卫星 ID 信息/ ID of satellite used	<Null>		十二信道的 Sv 信息（未使用则为空）/ Sv on Channel 12 (Null fields when it is not Used)
PDOP	1.07		综合位置精度因子/Position Dilution of Precision
HDOP	0.72		水平精度因子/Horizontal Dilution of Precision
VDOP	0.79		垂直精度因子/Vertical Dilution of Precision
校验值	*05		
EOL	<CR> <LF>		结束标志符/End of message termination

表 12.3-2/Table 10.3-2

值/Value	描述/Description
1	未定位
2	2D 定位
3	3D 定位

表 12.3-3 /Table 10.3-3

值/Value	描述/Description
M	手动选择 2D 或者 3D 模式
A	自动选择 2D 或者 3D 模式

12.4 GSV-可见卫星信息//GSV-GNSS Satellites in View

此语句包含可见卫星的 PRNs, 方位角和仰角等信息。

This sentence contains the mode of operation, type of fix, PRN of the satellites used in the solution as well as PDOP, HDOP and VDOP.

\$GPGSV,4,1,13,27,78,149,46,199,60,149,39,04,59,289,43,194,56,045,44,1*64

\$GPGSV,4,2,13,195,54,108,43,16,50,008,43,08,45,203,42,26,33,038,40,1*5A

\$GPGSV,4,3,13,09,28,313,33,31,28,098,42,193,26,167,39,03,11,233,39,1*52

\$GPGSV,4,4,13,22,,,35,1*60

\$GPGSV,3,1,10,27,78,149,50,199,60,149,48,04,59,289,46,194,56,045,45,8*6C

\$GPGSV,3,2,10,195,54,108,46,08,45,203,48,26,33,038,36,09,28,313,31,8*54

\$GPGSV,3,3,10,193,26,167,44,03,11,233,43,8*55

\$GLGSV,1,1,02,66,38,231,37,67,31,297,33,1*7A

\$GAGSV,1,1,02,05,,,41,24,,,41,7*72

\$GAGSV,1,1,02,05,,,45,24,,,41,1*70

\$GBGSV,3,1,11,07,65,346,40,37,50,357,43,23,33,068,26,10,32,262,41,1*7A

\$GBGSV,3,2,11,20,28,264,35,01,,,42,02,,,36,16,,,42,1*48

\$GBGSV,3,3,11,03,,,40,05,,,28,32,,,38,1*74

\$GBGSV,1,1,04,37,50,357,41,23,33,068,45,20,28,264,37,32,,,41,4*44

表 12.4-1 GSV 语句格式/ GSV Data Format

名称/Name	举例/Example	单位/Units	描述/Description
语句 ID/Message ID	\$GPGSV		表明此语句为 GSV 信息/GSV protocol header
GSV 总数信息/ Number of Message	4		本次 GSV 语句的总条数/ Total number of GSV sentences
GSV 条数信息/ Message Number	1		本条语句为 GSV 语句中的第几条/ Sentence number of the total
可见卫星信息/ Satellites in View	13		当前可见卫星总数/Number of satellites in view
卫星 ID/Satellite ID	27		
卫星仰角/Elevation	78	度/degrees	范围 00 到 90/ Range 00 to 90
卫星方位角/Azinmuth	149	度/degrees	范围 000 到 359/ Range 000 to 359
信噪比(C/NO)/SNR(C/NO)	46	dB-Hz	范围 00 到 99 (未使用则为空) / Range 00 to 99, null when not tracking
...			...
可见卫星信息/ Satellites in View	194		
卫星 ID/Satellite ID	56	度/degrees	范围 00 到 90/ Range 00 to 90
卫星仰角/Elevation	045	度/degrees	范围 000 到 359/ Range 000 to 359
卫星方位角/Azinmuth	44	dB-Hz	范围 00 到 99 (未使用则为空) / Range 00 to 99, null when not tracking
校验值/Checksum	*64		
EOL	<CR> <LF>		结束标志符/End of message termination

12.5 RMC-推荐定位信息/ RMC-Recommended Minimum locating information

此语句包含推荐定位的卫星定位信息。

This statement contains the satellite positioning information for the recommended location.

\$GNRMC,022326.000,A,2238.3443,N,11403.0962,E,0.01,169.33,120421,,,A,V*07

表 12.5-1: RMC 语句格式/ RMC Data Format

名称/Name	举例/Example	单位/Units	描述/Description
语句 ID/Message ID	\$GNRMC		表明此语句为 RMC 信息/RMC protocol header

UTC 时间/UTS Position	022326.000		hhmmss.sss
使用状态/Status	A		A=数据已使用 V=数据未使用/A=data valid or V=data not valid
纬度/Latitude	2238.3443		ddmm.mmmm
纬度 N/S/ N/S Indicator	N		N=北纬 S=南纬/N=north or S=south
经度/Longitude	11403.0962		dddmm.mmmm
经度 E/W /E/W Indicator	E		E=东经 W=西经/E=east or W=west
速度/ Speed Over Ground	0.01	节	
方位角/Course Over Ground	169.33	度	
UTC 日期/Date(UTC)	120421		ddmmyy
磁偏角/Magnetic variation	<Null>	度	未使用则为空/Null fields when it is not Used
磁偏角方位/Magnetic Variation Direction	<Null>		E=东经 W=西经 /E=east or W=west
定位模式/Fix Mode	A		A=自动, N=未定位, D=DGPS, E=DR/ A=autonomous, N = No fix, D=DGPS, E=DR
校验值/Checksum	*07		
EOL	<CR> <LF>		结束标志符/End of message termination

12.6 GLL-地理定位信息/Geographic Position – Latitude/Longitude

包含纬度和经度信息。

This sentence contains the fix latitude and longitude.

\$GNGLL, 2238.3443,N, 11403.0962,E, 022326.000,A,A*4F

表 12.6.1: GLL 数据格式/GLL Data Format

名称/Name	举例/Example	单位/Units	描述/Description
Message ID	\$GNGLL		GLL protocol header
Latitude	2238.3443		ddmm.mmmm
N/S Indicator	N		N=north or S=south
Longitude	11403.0962		dddmm.mmmm
E/W Indicator	E		E=east or W=west
UTC Position	022326.000		hhmmss.sss

Fix Status	A		A=data valid or V=data not valid
Fix Mode	A		A=autonomous, N = No fix, D=DGPS, E=DR
Checksum	*4F		
EOL	<CR> <LF>		End of message termination

12.7 VTG-地面速度信息/VTG-Course Over Ground and Ground Speed

此语句包含地面速度信息。

This statement contains the ground speed information.

\$GNVTG,169.33,T,,M,0.01,N,0.02,K,A*2E

表 12.7-1: VTG 语句格式/VTG statement format

名称/Name	举例/Example	单位/Units	描述/Description
语句 ID/Message ID	\$GNVTG		表明此语句为 VTG 信息/VTG protocol header
以真北为参考的地面航向 /Ground course with true north as reference	169.33		000~359 度，前面的 0 也将被传输/At 000~359 degrees, the front 0 will also be transmitted
间隔符/Blank character	T		
以磁北为参考的地面航向 /Ground heading with magnetic north as reference	<Null>		000~359 度，前面的 0 也将被传输/At 000~359 degrees, the front 0 will also be transmitted
间隔符/Blank character	M		
地面速率/Ground rate	0.01	Knots	000.0~999.9
间隔符 /Blank character	N		
地面速率/Ground rate	0.02	Km / h	0000.0~1851.8Km / h
间隔符 /Blank character	K		
模式指示/Mode indication	A		A=自主定位, D=差分, E=估算, N=数据无效/ A= autonomous localization, D= difference, E= imputation, and N= invalid data
EOL	<CR> <LF>		结束标志符/ End of message termination

12.8 ZDA-时间日期信息/ ZDA-Date and Time

此语句包含时间和日期信息

This sentence contains UTC date & time, and local time zone offset information.

\$GNZDA,022326.000,12,04,2021,,*49

表 12.8-1: ZDA 语句格式/ ZDA Data Format

名称/Name	举例/Example	单位/Units	描述/Description
语句 ID/Message ID	\$GNZDA		表明此语句为 ZDA 信息/ZDA protocol header
UTC 时间/UTC Time	022326.000		hhmmss (时分秒) 格式
UTC 日期/UTC data	12		日
UTC 日期/UTC Month	04		月
UTC 日期/UTC Year	2021		年
时区/local zone hours	<Null>		
校验值/Checksum	*49		
EOL	<CR> <LF>		结束标志符/ End of message termination

13 联系方式/ Contact Information

Skylab M&C Technology Co., Ltd.

深圳市天工测控技术有限公司

地址: 深圳市龙华区龙华街道工业东路利金城科技工业园 9# 厂房 6 楼

电话: 86-755 8340 8210 (Sales Support)

电话: 86-755 8340 8510 (Technical Support)

传真: 86-755-8340 8560

邮箱: technicalsupport@skylab.com.cn

网站: www.skylab.com.cn www.skylabmodule.com