

SKM89 Datasheet

L1+L5 GNSS module

Document Information

Title SKM89 High-performance L1+L5 GNSS module Datasheet

Document type Datasheet

Document number SL-22060255

Revision and date V1.01 15-May-2022

Disclosure restriction Public

Revision History:

Revision	Description	Approved	Date
V1.01	Initial Release	Wilson	20220515

SKYLAB reserves all rights to this document and the information contained herein. Products, names, logos and designs described herein may in whole or in part be subject to intellectual property rights. Reproduction, use, modification or disclosure to third parties of this document or any part thereof without the express permission of SKYLAB is strictly prohibited.

The information contained herein is provided "as is" and SKYLAB assumes no liability for the use of the information. No warranty, either express or implied, is given, including but not limited, with respect to the accuracy, correctness, reliability and fitness for a particular purpose of the information. This document may be revised by SKYLAB at any time. For most recent documents, visit www.skylab.com.cn.

Copyright © 2022, Skylab M&C Technology Co., Ltd.

SKYLAB® is a registered trademark of Skylab M&C Technology Co., Ltd in China.

Content

1 General Description	5
2 Applications	5
3 Features	6
4 Pin Assignment	6
5 Pin Description	7
6 Interfaces Configuration	7
Power Supply	7
UART Ports	7
PPS	7
7 Advanced Software Features	8
Standby Mode	8
Periodic Mode	8
Always Locate™	8
AGPS Support for Fast TTFF (EPO™)	8
EASY™	9
Embedded Logger function	9
GNSS	9
8 Performance introduction	9
9 Electrical Characteristics	10
Absolute Maximum Rating	10
Operating Conditions	11
10 Mechanical Specification	12
11 Software Protocol	13
NMEA 0183 Protocol	13
GGA-Global Positioning System Fixed Data	13

GSA-GNSS DOP and Active Satellites	14
GSV-GNSS Satellites in View	15
RMC-Recommended Minimum Specific GNSS Data	17
VTG-Course Over Ground and Ground Speed	18
ZDA-Date and Time	18
CMD List	19
12 Contact Information	20

3 Features

- ◆ L1 + L5 dual band, L1 supports GPS, GLO, GAL, BDS, QZSS and SBAS systems Ultra high sensitivity: -164dBm, L5 supports GPS, GAL, BDS and QZSS
- ◆ NMEA protocol (default baud rate: 115200 BPS)
- ◆ Internal spare battery
- ◆ Embedded ceramic antenna 25 x 25 x 2.5mm and 18.2 x 18.2 x 2.0mm
- ◆ Advanced Features: Always Locate; EPO; EASY, NVRAM, hotstill
- ◆ Operating temperature range: -40~85°C
- ◆ Compliance with ROHS, CE, FCC standards
- ◆ Size: 30* 26* 8mm

4 Pin Assignment

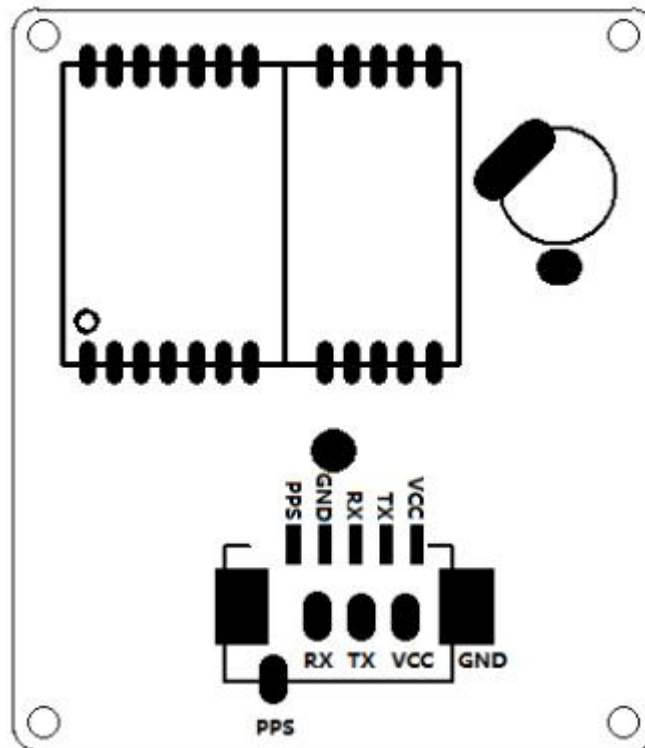

Figure 2: SKM89 Pin Package

5 Pin Description

Pin No.	Pin name	I/O	Description	Remark
1	VCC	P	Module Power Supply	Operating range: 3.3V to 5.5V
2	TXD	O	UART Serial Data Output	Leave open if not used
3	RXD	I	UART Serial Data Input	Leave open if not used
4	GND	G	Ground	
5	PPS	O	Time pulse Signal (100ms)	Leave open if not used

6 Interfaces Configuration

Power Supply

Regulated power for the SKM89 is required. SKM89 series input voltage VCC range is 3.3V ~ 5.5V, current requirement is greater than 100mA. Place decoupling capacitors (10uF and 1uF) close to the interface power supply.

It can reduce the Noise from power supply and increase power stability.

Main power supply VCC current varies according to the processor load and satellite acquisition. Maximum VCC peak current is about 57mA during acquisition.

UART Ports

The module supports one full duplex serial channels UART. The SKM89 series uses a single-chip RS232 to UART bridge, which is 3.3V driven EIA/TIA-232 and V.28/V.24. The modules default baud rate is set up 115200bps.

PPS

A pulse per second (1 PPS) is an electrical signal that very precisely indicates the start of a second. Depending on the source, properly operating PPS signals have an accuracy ranging 15ns. The PPS signals are used for precise timekeeping and time measurement.

7 Advanced Software Features

Standby Mode

User can issue software command to make GNSS module go into standby mode that consumes less than 200uA current. GNSS module will be awakened when receiving any byte. The following flow chart is an example to make GNSS module go into standby mode and then wake up.

Periodic Mode

When GNSS module is commanded to periodic mode, it will be in operation and standby periodically. Its status of power consumption is as below chart.

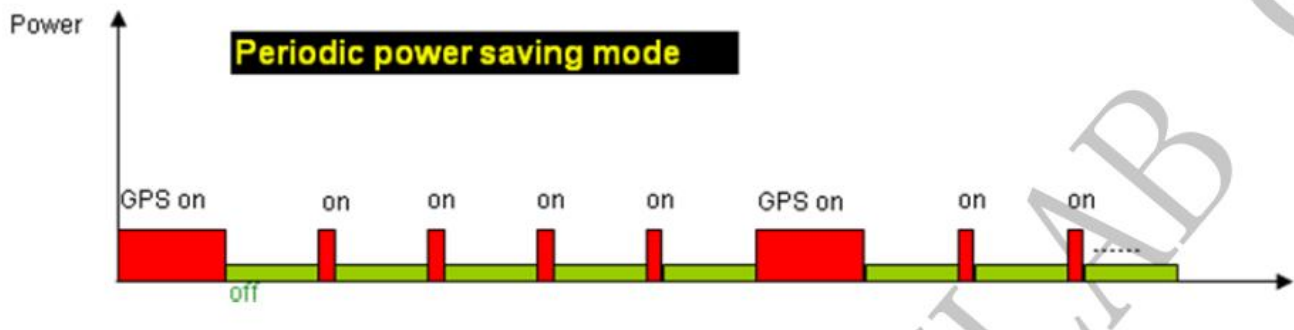

Always Locate™

Always Locate™ is an intelligent controller of periodic mode. Depending on the environment and motion conditions, GNSS module can adaptive adjust working/standby time to achieve balance of positioning accuracy and power consumption. In this mode, the host CPU does not need to control GNSS module until the host CPU needs the GPS position data. The following flow chart is an example to make GNSS module go into Always Locate™ mode and then back to normal operation mode.

AGPS Support for Fast TTFF (EPO™)

The AGPS (EPO™) supply the predicated Extended Prediction Orbit data to speed TTFF, users can download the EPO data to GPS engine from the FTP server by internet or wireless network, the GPS engine

will use the EPO data to assist position calculation when the navigation information of satellites are not enough or weak signal zone.

EASY™

The EASY™ is embedded assist system for quick positioning, the GPS engine will calculate and predict automatically the single emperies (Max. up to 3 days)when power on, and save the predict information into the memory, GPS engine will use these information for positioning if no enough information from satellites, so the function will be helpful for positioning and TTFF improvement under indoor or urban condition, the Backup power (VBACKUP)is necessary.

Embedded Logger function

The Embedded Logger function don't need host CPU (MCU)and external flash to handle the operation, GPS Engine will use internal flash (embedded in GPS chipset)to log the GPS data (Data format: UTC, Latitude, longitude, Valid, Checksum), the max log days can up to 2 days under Always Locate™ condition.

GNSS

The SKM89 GNSS modules can receive and track multiple GNSS systems (e.g. GPS, GLONASS and BeiDou signals). The SKM89 can be configure to start searching of which satellite system. By default the receivers are configured for concurrent GPS and GLONASS reception.

8 Performance introduction

Parameter	Specification	
Type of receipt	GPS+GLONASS+GALILEO+BDS+QZSS	
Sensitivity	Tracking	-164dBm
	Acquisition	-146dBm
Accuracy	Position	<1.7m CEP50 without SA(Open Sky)
	Velocity	0.1m/s without SA

	PPS	±15ns
Acquisition Time	Cold Start	28s(Typical Open Sky)
	Warm Start	24s
	Hot Start	1s
	Re-Acquisition	<1s
Assisted GPS support	EPO	
Power Consumption	Tracking	55mA
	Acquisition	53mA
Navigation data update frequency	Max 10Hz	Default 1Hz
Operational Limits	Altitude	Max 18,000m
	Velocity	Max 515m/s
	Acceleration	Less than 4g

9 Electrical Characteristics

Absolute Maximum Rating

Parameter	Symbol	Min	Max	Units
Power Supply				
Power Supply Volt.	VCC	-0.3	5.5	V
Input Pins				
Input voltage on any input connection	VIO	-0.3	3.6	V
RF input power	RF_IN		-40	dBm
Human Body Model ESD capability	RF_IN		2000	V
Machine Model ESD capability	RF_IN		100	V
Environment				
Storage Temperature	Tstg	-40	125	°C
Humidity			95	%

Note: Absolute maximum ratings are stress ratings only, and functional operation at the maxims is not guaranteed. Stress beyond the limits specified in this table may affect device reliability or cause permanent damage to the device. For functional operating conditions, refer to the operating conditions tables as follow.

Operating Conditions

Parameter	Symbol	Condition	Min	Typ	Max	Units
Power supply voltage	VCC		3.3	5	5.5	V
Power supply voltage ripple	VCC_PP	VCC=5V			30	mV
Supply current, Acquisition	ICC	VCC=5V		55		mA
Supply current, Tracking	ICC	VCC=5V		53		mA
Input high voltage	V _{IH}		2		3.6	V
Input low voltage	V _{IL}		-0.3		0.8	V
Output high voltage	V _{OH}		2.4		3.1	V
Output low voltage	V _{OL}		-0.3		0.4	V
Operating temperature	T _{opr}		-40		85	°C

10 Mechanical Specification

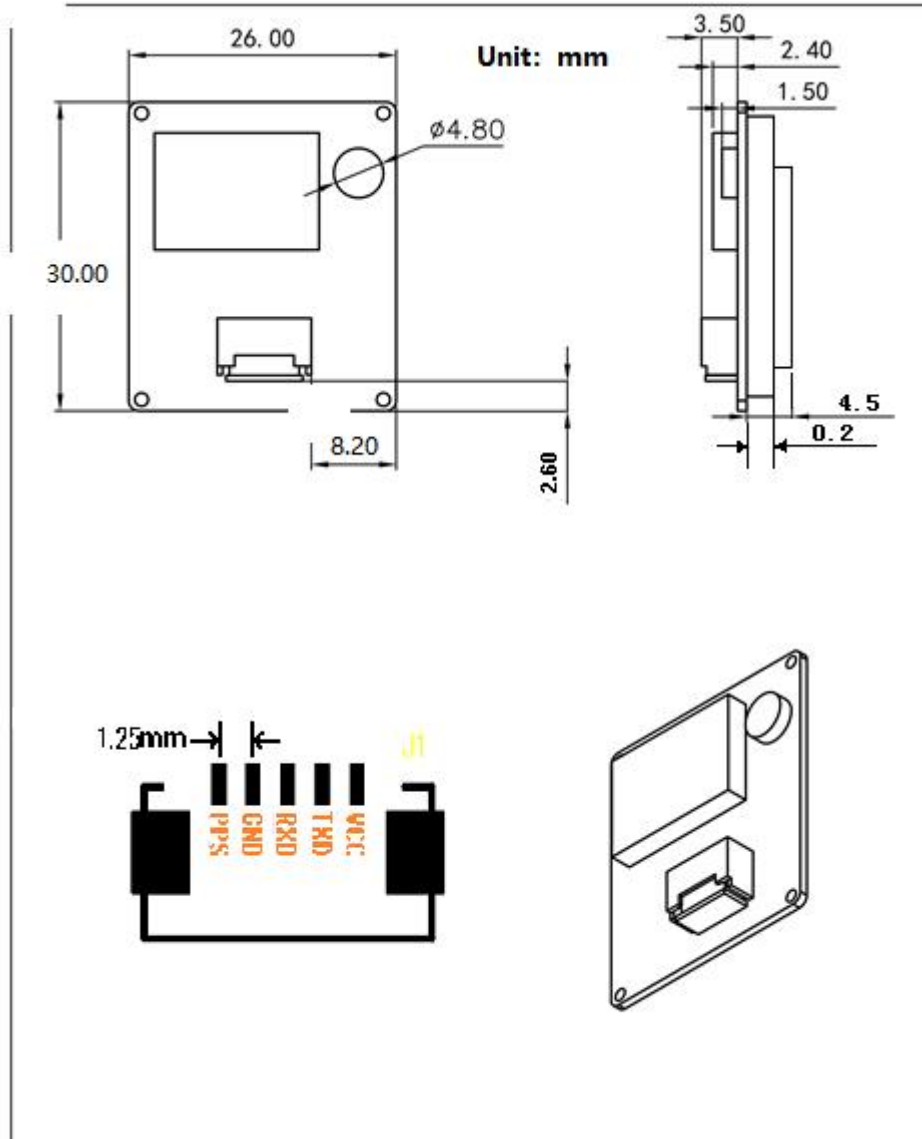

Figure 3: SKM89 Dimensions

11 Software Protocol

NMEA 0183 Protocol

The NMEA protocol is an ASCII-based protocol, Records start with a \$ and with carriage return/line feed. GPS specific messages all start with \$GNxxx where xxx is a three-letter identifier of the message data that follows. NMEA messages have a checksum, which allows detection of corrupted data transfers.

The Skylab SKM89 supports the following NMEA-0183 messages: GGA, GLL,GSA, GSV, RMC,VTG, ZDA. The module default NMEA-0183 output is set up GGA、 GLL、 GSA、 RMC、 GSV、 VTG、 ZDA and default baud rate is set up 115200bps.

Table 1: NMEA-0183 Output Messages

NMEA Record	Description	Default
GGA	Global positioning system fixed data	Y
GLL	Geographic position—latitude/longitude	Y
GSA	Global DOP and active satellites for GLONASS	Y
GSV	GNSS satellites in view for GPS	Y
RMC	Recommended minimum specific GNSS data	Y
VTG	Course over ground and ground speed	Y
ZDA	Date and Time	Y

GGA-Global Positioning System Fixed Data

This sentence contains the position, time and quality of the navigation fix.

See RMC for Fix Status, Fix Mode, Fix Date, Speed, and True Course.

See GSA for Fix Type, PDOP, and VDOP.

\$GNGGA,022326.000,2238.3443,N,11403.0962,E,1,22,0.72,104.0,M,-2.2,M,,*69

Table 2: GGA Data Format

Name	Example	Units	Description
Message ID	\$GNGGA		GGA protocol header
UTC Position	022326.000		hhmmss.sss
Latitude	2238.3443		ddmm.mmmm
N/S indicator	N		N=north or S=south
Longitude	11403.0962		dddmm.mmmm
E/W Indicator	E		E=east or W=west
Position Fix Indicator	1		See Table 2-1
Satellites Used	22		Range 0 to 12
HDOP	0.72		Horizontal Dilution of Precision
MSL Altitude	104.0	meters	Altitude (referenced to the Ellipsoid)
AltUnit	M	meters	Altitude Unit
GeoSep	-2.2	meters	Geoidal Separation
GeoSepUnit	M	meters	Geoidal Separation Unit
Age of Diff.Corr.	<Null>	second	Null fields when it is not Used
Diff.Ref.Station ID	<Null>		Null fields when it is not Used
Checksum	*69		
EOL	<CR> <LF>		End of message termination

Table 2-1: Position Fix Indicators

Value	Description
0	Fix not available or invalid
1	fix valid
2	Differential GPS, fix valid

GSA-GNSS DOP and Active Satellites

This sentence contains the mode of operation, type of fix, PRNs of the satellites used in the solution as well as PDOP, HDOP and VDOP.

\$GNGSA,A,3,199,195,08,26,09,31,16,194,193,27,03,04,1.07,0.72,0.79,1*05

\$GNGSA,A,3,67,66,,,,,,,,,1.07,0.72,0.79,2*0E

\$GNGSA,A,3,,,,,,,,,,,,,1.07,0.72,0.79,3*0E

\$GNGSA,A,3,37,20,07,,,,,,,,,,,,,1.07,0.72,0.79,4*08

Table 4: GSA Data Format

Name	Example	Units	Description
Message	\$GPGSA		GSA protocol header
Mode 1	A		See Table 4-2
Mode 2	3		See Table 4-1
ID of satellite used	199		Sv on Channel 1
ID of satellite used	195		Sv on Channel 2
...
ID of satellite used	<Null>		Sv on Channel 12 (Null fields when it is not Used)
PDOP	1.07		Position Dilution of Precision
HDOP	0.72		Horizontal Dilution of Precision
VDOP	0.79		Vertical Dilution of Precision
Checksum	*05		
EOL	<CR> <LF>		End of message termination

Table 4-1: Mode 2

Value	Description
1	Fix not available
2	2D Fix
3	3D Fix

Table 4-2: Mode 1

Value	Description
M	Manual-forced to operate in 2D or 3D mode
A	Automatic-allowed to automatically switch 2D/3D

GSV-GNSS Satellites in View

This sentence contains the PRNs, azimuth, elevation, and signal strength of all satellites in view.

\$GPGSV,4,1,13,27,78,149,46,199,60,149,39,04,59,289,43,194,56,045,44,1*64

\$GPGSV,4,2,13,195,54,108,43,16,50,008,43,08,45,203,42,26,33,038,40,1*5A

\$GPGSV,4,3,13,09,28,313,33,31,28,098,42,193,26,167,39,03,11,233,39,1*52

\$GPGSV,4,4,13,22,,,35,1*60

\$GPGSV,3,1,10,27,78,149,50,199,60,149,48,04,59,289,46,194,56,045,45,8*6C

\$GPGSV,3,2,10,195,54,108,46,08,45,203,48,26,33,038,36,09,28,313,31,8*54

\$GPGSV,3,3,10,193,26,167,44,03,11,233,43,8*55

\$GLGSV,1,1,02,66,38,231,37,67,31,297,33,1*7A

\$GAGSV,1,1,02,05,,,41,24,,,41,7*72

\$GAGSV,1,1,02,05,,,45,24,,,41,1*70

\$GBGSV,3,1,11,07,65,346,40,37,50,357,43,23,33,068,26,10,32,262,41,1*7A

\$GBGSV,3,2,11,20,28,264,35,01,,,42,02,,,36,16,,,42,1*48

\$GBGSV,3,3,11,03,,,40,05,,,28,32,,,38,1*74

\$GBGSV,1,1,04,37,50,357,41,23,33,068,45,20,28,264,37,32,,,41,4*44

Table 5: GSV Data Format

Name	Example	Units	Description
Message ID	\$GPGSV		GSV protocol header
Number of Message	4		Total number of GSV sentences (Range 1 to 3)
Message Number	1		Sentence number of the total (Range 1 to 3)
Satellites in View	13		Number of satellites in view
Satellite ID	27		Channel 1
Elevation	78	degrees	Channel 1(Range 00 to 90)
Azinmuth	149	degrees	Channel 1(Range 000 to 359)
SNR(C/NO)	46	dB-Hz	Channel 1(Range 00 to 99, null when not tracking)
...			...
Satellite ID	194		Channel 4
Elevation	56	degrees	Channel 4(Range 00 to 90)

Azimuth	045	degrees	Channel 4(Range 000 to 359)
SNR(C/NO)	44	dB-Hz	Channel 4(Range 00 to 99, null when not tracking)
Checksum	*64		
EOL	<CR> <LF>		End of message termination

Depending on the number of satellites tracked multiple messages of GSV data may be required.

RMC-Recommended Minimum Specific GNSS Data

This sentence contains the recommended minimum fix information.

See GGA for Fix Quality, Sats Used, HDOP, Altitude, Geoidal Separation, and DGPS data.

See GSA for Fix Type, PDOP and VDOP.

\$GNRMC,022326.000,A,2238.3443,N,11403.0962,E,0.01,169.33,230422,,,A,V*06

Table 6: RMC Data Format

Name	Example	Units	Description
Message ID	\$GNRMC		RMC protocol header
UTS Position	022326.000		hhmmss.sss
Status	A		A=data valid or V=data not valid
Latitude	2238.3443		ddmm.mmmm
N/S Indicator	N		N=north or S=south
Longitude	11403.0962		dddmm.mmmm
E/W Indicator	E		E=east or W=west
Speed Over Ground	0.01	Knots	
Course Over Ground	169.33	Degrees	True Course
Date(UTC)	230422		ddmmyy
Magnetic variation	<Null>	Degrees	Null fields when it is not Used
Magnetic Variation Direction	<Null>		E=east or W=west (Null fields when it is not Used)
Fix Mode	A		A=autonomous, N = No fix, D=DGPS, E=DR
Checksum	*06		
EOL	<CR> <LF>		End of message termination

VTG-Course Over Ground and Ground Speed

This sentence contains the course and speed of the navigation solution.

\$GNVTG,169.33,T,,M,0.01,N,0.02,K,A*2E

Table 7: VTG Data Format

Name	Example	Units	Description
Message ID	\$GPVTG		VTG protocol header
Tcourse	169.33	Degrees	True Course
Reference	T		T = True
Mcourse	<Null>	Degrees	Magnetic Course (Null fields when it is not Used)
Reference	M		M = Magnetic (Null fields when it is not Used)
Speed over ground	0.01	Knots	Nautical Miles per Hour
Units	N		Knots
Speed over ground	0.24	Km/hr	in Kilometers per Hour
Units	K		Kilometer per hour
Mode	A		A=Autonomous, N=No fix, D=DGPS, E=DR
Checksum	*23		
EOL	<CR> <LF>		End of message termination

ZDA-Date and Time

This sentence contains UTC date & time, and local time zone offset information.

\$GNZDA,022326.000,23,04,2022,,*48

Table 8: ZDA Data Format

Name	Example	Units	Description
Message ID	\$GPZDA		ZDA protocol header
UTC Time	022326.000		hhmmss.sss
Day	23		UTC time: day (01 ... 31) dd
Month	04		UTC time: month (01 ... 12) mm
Year	2022		UTC time: year (4 digit year) yyyy
local zone hours	<Null>		Local Time Zone Offset Hours (Null fields when it is not Used)
local zone minutes	<Null>		Local Time Zone Offset Minutes (Null fields when it is not Used)
Checksum	*48		
EOL	<CR> <LF>		End of message termination

CMD List

Table 9: CMD List

CMD TYPE	CMD Example:
Hot Restart	\$PAIR004*3E<CR><LF>
Warm Restart	\$PAIR005*3F<CR><LF>
Cold Restart	\$PAIR006*3C<CR><LF>
Full Cold Restart	\$PAIR007*3D<CR><LF>
Search GPS satellites only	\$PAIR066,1,0,0,0,0,0*3B<CR><LF>
Search G3B+QZSS satellites	\$PAIR066,1,1,1,1,1,0*3B<CR><LF>
Search GPS and BEIDOU satellites	\$PAIR066,1,0,0,1,0,0*3A<CR><LF>
Search GPS and GLONASS satellites	\$PAIR066,1,1,0,0,0,0*3A<CR><LF>
Search GPS and Galileo satellites	\$PAIR066,1,0,1,0,0,0*3A<CR><LF>

12 Contact Information

Skylab M&C Technology Co., Ltd.

深圳市天工测控技术有限公司

Address: 6 Floor, No.9 Building, Lijincheng Scientific & Technical park, Gongye East Road,
Longhua District, Shenzhen, Guangdong, China

Phone: 86-755 8340 8210 (Sales Support)

Phone: 86-755 8340 8510 (Technical Support)

Fax: 86-755-8340 8560

E-Mail: technicalsupport@skylab.com.cn

Website: www.skylab.com.cn www.skylabmodule.com