

SKG09A Datasheet

GPS Module

Document Information

Title	SKG09A Ultra High Sensitivity and Low Power GPS Receiver Module Datasheet	
Document type	Datasheet	
Revision and date	V3.02	29-Apr-2021
Disclosure restriction	Public	

Revision History

Revision	Description	Approved	Date
V1.01	Initial release to 001	Woody	20130729
V2.01	Reducing power consumption	Woody	20140601
V3.01	Update FW	Woody	20150417
V3.02	Update format	Wendy	20210429

SKYLAB reserves all rights to this document and the information contained herein. Products, names, logos and designs described herein may in whole or in part be subject to intellectual property rights. Reproduction, use, modification or disclosure to third parties of this document or any part thereof without the express permission of SKYLAB is strictly prohibited.

The information contained herein is provided “as is” and SKYLAB assumes no liability for the use of the information. No warranty, either express or implied, is given, including but not limited, with respect to the accuracy, correctness, reliability and fitness for a particular purpose of the information. This document may be revised by SKYLAB at any time. For most recent documents, visit www.skylab.com.cn.

Copyright © 2013, Skylab M&C Technology Co., Ltd.

SKYLAB® is a registered trademark of Skylab M&C Technology Co., Ltd in China.

Contents

1 General Description.....	5
2 Applications.....	5
3 Features.....	6
4 Pin Assignment.....	6
5 Pin Description.....	7
6 Interfaces Configuration.....	8
Power Supply.....	8
Backup Battery Power.....	8
Antenna.....	8
VCC_RF.....	8
UART Ports.....	8
EXTINT.....	9
RF_IN.....	9
PPS.....	9
7 Advanced Software Features.....	9
Standby Mode.....	9
Periodic Mode.....	9
AlwaysLocate™.....	10
AGPS Support for Fast TTFF (EPO™).....	10
EASY™.....	10
Embedded Logger function.....	11
AIC_Multi-tone active interference canceller.....	11
FLP Mode.....	11
8 Performance Specification.....	11
9 Electrical Characteristics.....	12

Absolute Maximum Rating.....	12
Operating Conditions.....	13
10 Mechanical Specification.....	13
Recommend Layout.....	14
11 Reference design schematic.....	15
12 Packaging Specification.....	15
13 Manufacturing Process Recommendations.....	16
14 Software Protocol.....	17
NMEA 0183 Protocol.....	17
GGA-Global Positioning System Fixed Data.....	17
GLL-Geographic Position – Latitude/Longitude.....	18
GSA-GNSS DOP and Active Satellites.....	19
GSV-GNSS Satellites in View.....	20
RMC-Recommended Minimum Specific GNSS Data.....	20
VTG-Course Over Ground and Ground Speed.....	21
ZDA-Date and Time.....	22
CMD List.....	23
15 Contact Information.....	23

1 General Description

The SKG09A is a complete GPS engine module that features super sensitivity, ultra low power and small form factor. The GPS signal is applied to the antenna input of module, and a complete serial data message with position, velocity and time information is presented at the serial interface with NMEA protocol or custom protocol.

It is based on the high performance features of the single-chip architecture, Its -165dBm tracking sensitivity extends positioning coverage into place like urban canyons and dense foliage environment where the GPS was not possible before. The small form factor and low power consumption make the module easy to integrate into portable device like PNDs, mobile phones, cameras and vehicle navigation systems.



Figure 1: SKG09A Top View

2 Applications

- ◆ LBS (Location Based Service)
- ◆ PND (Portable Navigation Device)
- ◆ Vehicle navigation system
- ◆ Mobile phone

3 Features

- ◆ Ultra high sensitivity: -165dBm
- ◆ Extremely fast TTFF at low signal level
- ◆ Built-in 12 multi-tone active interference canceller
- ◆ Ultra low power consumption
- ◆ ±10ns high accuracy time pulse (1PPS)
- ◆ Advanced Features: AlwaysLocate; AIC; EPO;EASY; FLP
- ◆ QZSS, SBAS (WAAS,EGNOS,MSAS,GAGAN)
- ◆ Indoor and outdoor multi-path detection and compensation
- ◆ Small form factor: 10.1 x 9.7 x 2.2mm
- ◆ RoHS compliant (Lead-free)

4 Pin Assignment

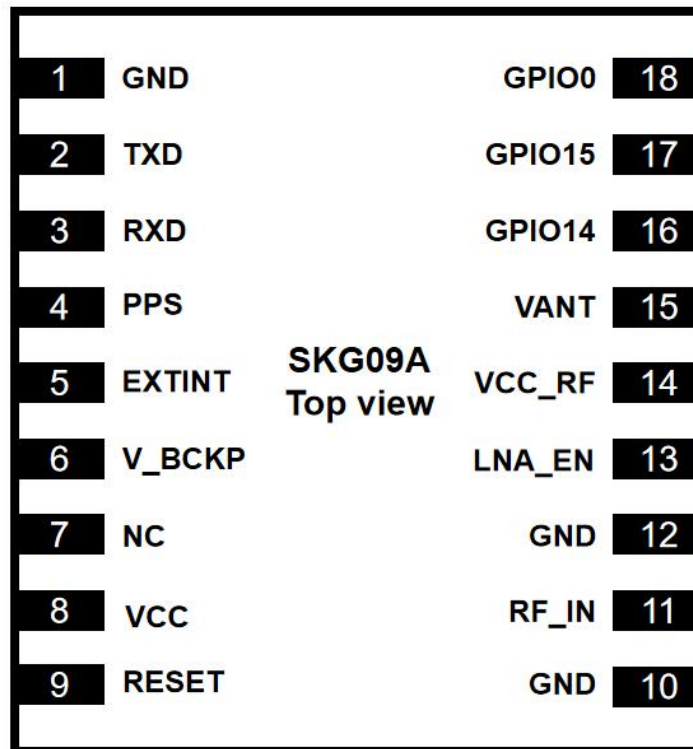

Figure 2: SKG09A Pin Package

5 Pin Description

Pin No.	Pin name	I/O	Description	Remark
1	GND	G	Ground	Leave open if not used
2	TXD	O	UART serial data output.	Leave open if not used
3	RXD	I	UART serial data input.	Leave open if not used
4	PPS	O	Time pulse signal.	Leave open if not used
5	EXTINT	I	External Interrupt pin.	Leave open if not used
6	V_BCKP	I	RTC and backup SRAM power.	This pin may be connect to Battery or power supply(2.0~4.2V)
7	NC			
8	VCC	I	Module power supply.	Operating range: 3.0V to 4.2V
9	RESET	I	Module reset (Active Low).	Leave open if not used
10	GND	G	Ground	
11	RF_IN	I	GPS signal input.	50Ω@1.57542GHz, DC block inside
12	GND	G	Ground	
13	LNA_EN	O	2.8V output for optional control of external LNA bias switch, active high.	Leave open if not used
14	VCC_RF	O	VCC power output.	Leave open if not used
15	VANT	I	Active antenna voltage supply.	Leave open if not used
16	GPIO14	I/O	General purpose I/O.	Leave open if not used
17	GPIO15	I/O	General purpose I/O.	Leave open if not used
18	GPIO0	I/O	General purpose I/O.	Leave open if not used

6 Interfaces Configuration

Power Supply

Regulated power for the SKG09A is required. The input voltage Vcc should be 3.0V to 4.2V range, current is no less than 100mA. Suitable decoupling must be provided by external decoupling circuitry (10uF and 1uF). It can reduce the Noise from power supply and increase power stability.

Main power supply Vcc current varies according to the processor load and satellite acquisition. Maximum Vcc peak current is about 25 mA during acquisition.

Backup Battery Power

In case of a power failure on pin Vcc, real-time clock and backup RAM are supplied through pin V_BCKP. This enables the SKG09A GPS Receiver to recover from power failure with either a hot start or a warm start (depending on the duration of Vcc outage). If no Backup Battery is connected, the receiver performs a cold start upon powered up.

Backup Battery Power V_BCKP draws typically 7 uA current in backup state.

Antenna

The SKG09A GPS receiver is designed for supporting the active antenna or passive antenna connected with pin RF_IN. The gain of active antenna should be no more than 25dB (18~20dB Typical). The maximum noise figure should be no more than 1.5dB and output impedance is at 50 Ohm.

VCC_RF

Antenna power output pin. When user wants to use external active antenna. The pin supply power for active antenna.

UART Ports

The module supports one full duplex serial channels UART. The serial connections are at 2.85V LVTTTL logic

levels, if need different voltage levels, use appropriate level shifters. the data format is however fixed: X, N, 8, 1, i.e. X baud rate, no parity, eight data bits and one stop bit, no other data formats are supported, LSB is sent first. The modules default baud rate is set up 9600bps. The RXD0 & TXD0 recommended to pull up (10K Ω). It can increase the stability of serial data.

EXTINT

The default EXTINT function is Standby mode control but the function is not supported; leave signal floating (not connected).

RF_IN

The transmission line must to be control impedance from RF_IN pin to the antenna or antenna connector of your choice. (Impedance 50 Ω)

PPS

A pulse per second (1 PPS) is an electrical signal that very precisely indicates the start of a second. Depending on the source, properly operating PPS signals have an accuracy ranging 10ns. The PPS signals are used for precise timekeeping and time measurement.

7 Advanced Software Features

Standby Mode

User can issue software command to make GPS module go into standby mode that consumes less than 200uA current. GPS module will be awaked when receiving any byte. The following flow chart is an example to make GPS module go into standby mode and then wake up.

Periodic Mode

When GPS module is commanded to periodic mode, it will be in operation and standby periodically. Its status of power consumption is as below chart.

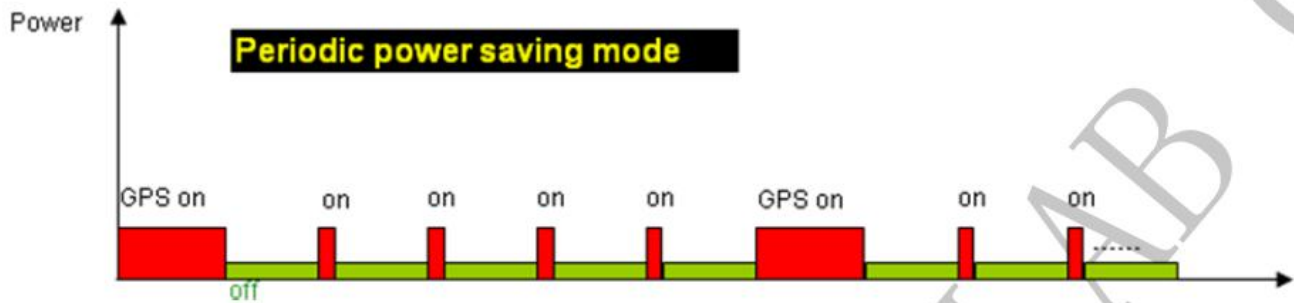

AlwaysLocate™

AlwaysLocate™ is an intelligent controller of periodic mode. Depending on the environment and motion conditions, GPS module can adaptively adjust working/standby time to achieve balance of positioning accuracy and power consumption. In this mode, the host CPU does not need to control GPS module until the host CPU needs the GPS position data. The following flow chart is an example to make GPS module go into AlwaysLocate™ mode and then back to normal operation mode.

AGPS Support for Fast TTFF (EPO™)

The AGPS (EPO™) supply the predicated Extended Prediction Orbit data to speed TTFF, users can download the EPO data to GPS engine from the FTP server by internet or wireless network, the GPS engine will use the EPO data to assist position calculation when the navigation information of satellites are not enough or weak signal zone.

EASY™

The EASY™ is embedded assist system for quick positioning, the GPS engine will calculate and predict automatically the single emperies (Max. up to 3 days) when power on, and save the predict information into the memory, GPS engine will use these information for positioning if no enough information from satellites, so the function will be helpful for positioning and TTFF improvement under indoor or urban condition, the Backup power (VBACKUP) is necessary.

Embedded Logger function

The Embedded Logger function don't need host CPU (MCU) and external flash to handle the operation , GPS Engine will use internal flash (embedded in GPS chipset) to log the GPS data (Data format : UTC, Latitude , longitude, Valid ,Checksum), the max log days can up to 2 days under AlwaysLocate™ condition .

AIC_Multi-tone active interference canceller

Because different application (Wi-Fi , GSM/GPRS,3G/4G,Bluetooth)are integrated into navigation system , the harmonic of RF signal will influence the GPS reception , The multi- tone active-interference canceller can reject external RF interference which come from other active components on the main board , to improve the capacity of GPS reception without any needed HW change in the design .SKG09A can cancel up to 12 independent channel interference continuous wave.

FLP Mode

With FLP mode,the power consumption can be reduced greatly,but positioning accuracy will be effected and need Special firmware to Support.

8 Performance Specification

Parameter	Specification	
Receiver Type	L1 frequency band, C/A code, 22 Tracking / 66 Acquisition-Channel	
Sensitivity	Tracking Acquisition	-165dBm Typical -148dBm Typical
Accuracy	Position Velocity Timing (PPS)	3.0m CEP50 without SA(Typical Open Sky) 0.1m/s without SA 10ns RMS
Acquisition Time	Cold Start Warm Start Hot Start Re-Acquisition	23s(Typical Open Sky) 2-3s 1s <1s
Assisted GPS support	EPO	
Power Consumption	Tracking Acquisition	16mA @Typical 8mA@FLP mode 19mA @Typical 19mA @ FLP mode

Navigation Data Update Rate	Max 10Hz	Default 1Hz
Operational Limits	Altitude Velocity Acceleration	Max 18,000m Max 515m/s Less than 4g

9 Electrical Characteristics

Absolute Maximum Rating

Parameter	Symbol	Min	Max	Units
Power Supply				
Power Supply Volt.	VCC	-0.3	4.3	V
Input Pins				
Input voltage on any input connection	VIO	-0.3	3.6	V
Backup Battery	V_BCKP	-0.3	4.3	V
RF input power	RF_IN		-40	dBm
Human Body Model ESD capability	RF_IN		2000	V
Machine Model ESD capability	RF_IN		100	V
Environment				
Storage Temperature	Tstg	-40	125	°C
Peak Reflow Soldering Temperature <10s	Tpeak		260	°C
Humidity			95	%

Note: Absolute maximum ratings are stress ratings only, and functional operation at the maxims is not guaranteed. Stress beyond the limits specified in this table may affect device reliability or cause permanent damage to the device. For functional operating conditions, refer to the operating conditions tables as follow. The SKG09A module is Electrostatic Sensitive Device (ESD) and may be damaged with ESD or spike voltage. Although it has built-in ESD protection circuitry at digital I/O, please handle with care to avoid permanent malfunction or performance degradation. Note that RFIN has no ESD protection circuits.

Operating Conditions

Parameter	Symbol	Condition	Min	Typ	Max	Units
Power supply voltage	Vcc		3	3.3	4.2	V
Backup Battery	V_BCKP		2	3.3	4.2	V
Power supply voltage ripple	Vcc_PP	Vcc=3.3V			30	mV
Supply current, Acquisition	Icc	Vcc=3.3V		19		mA
Supply current, Tracking	Icc	Vcc=3.3V		16		mA
Supply current, backup state	Ibckp	Vcc=3.3V		7		uA
VCC_RF Antenna bias supply	VCC_RF			Vcc		V
Input high voltage	V _{IH}		2		3.6	V
Input low voltage	V _{IL}		-0.3		0.8	V
Output high voltage	V _{OH}		2.4		3.1	V
Output low voltage	V _{OL}		-0.3		0.4	V
Operating temperature	T _{opr}		-40		85	°C

10 Mechanical Specification

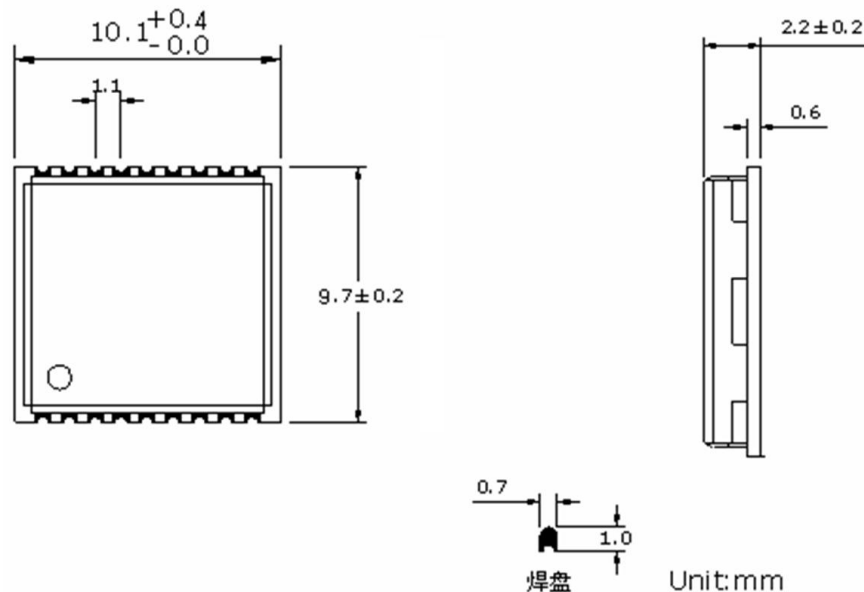

Parameter	specification	Units
Coplanarity	≤ 0.1	mm

Figure 3: SKG09A Dimensions

Recommend Layout

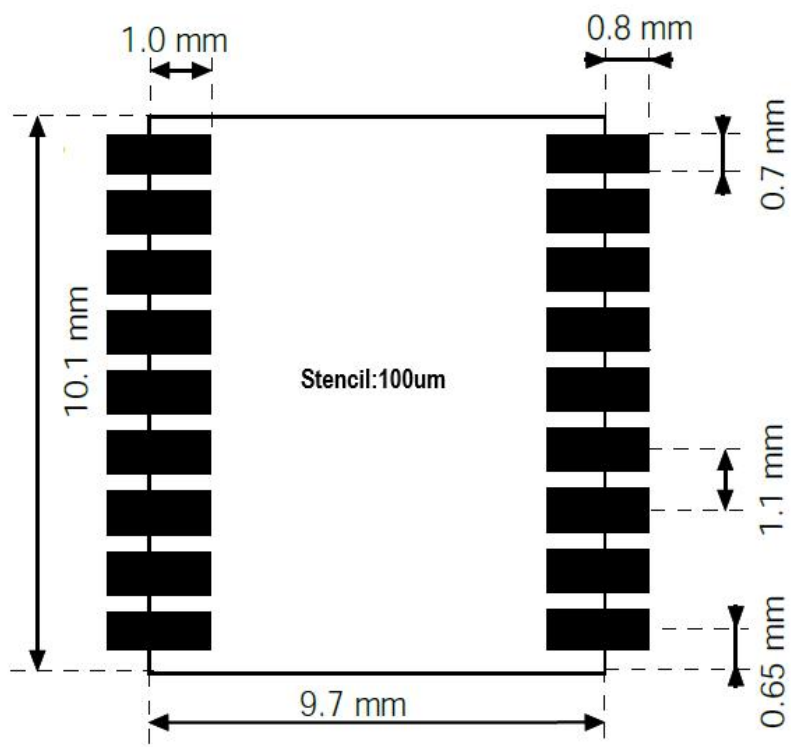

Figure 4: SKG09A Footprint

11 Reference design schematic

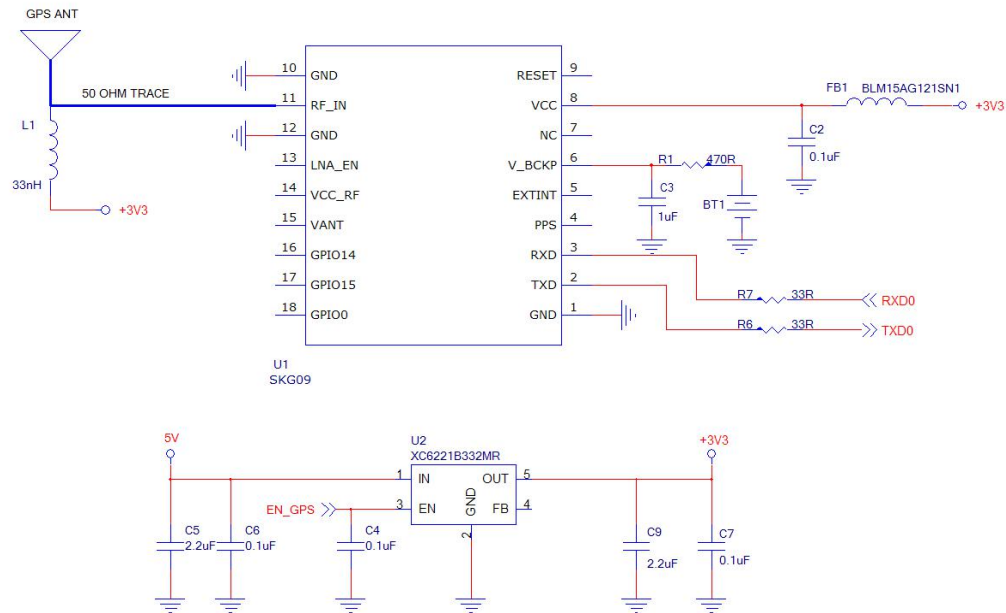

Figure 5: SKG09A Typical Reference design schematic

12 Packaging Specification

SKG09A modules are shipped in reel and with 2000 units per reel. Each tray is 'dry' package.

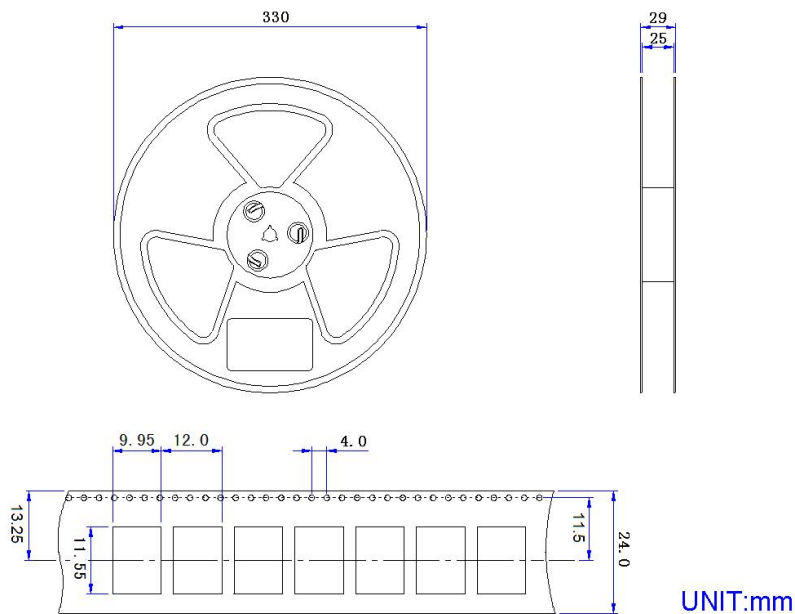

Figure 6: SKG09A Packaging

13 Manufacturing Process Recommendations

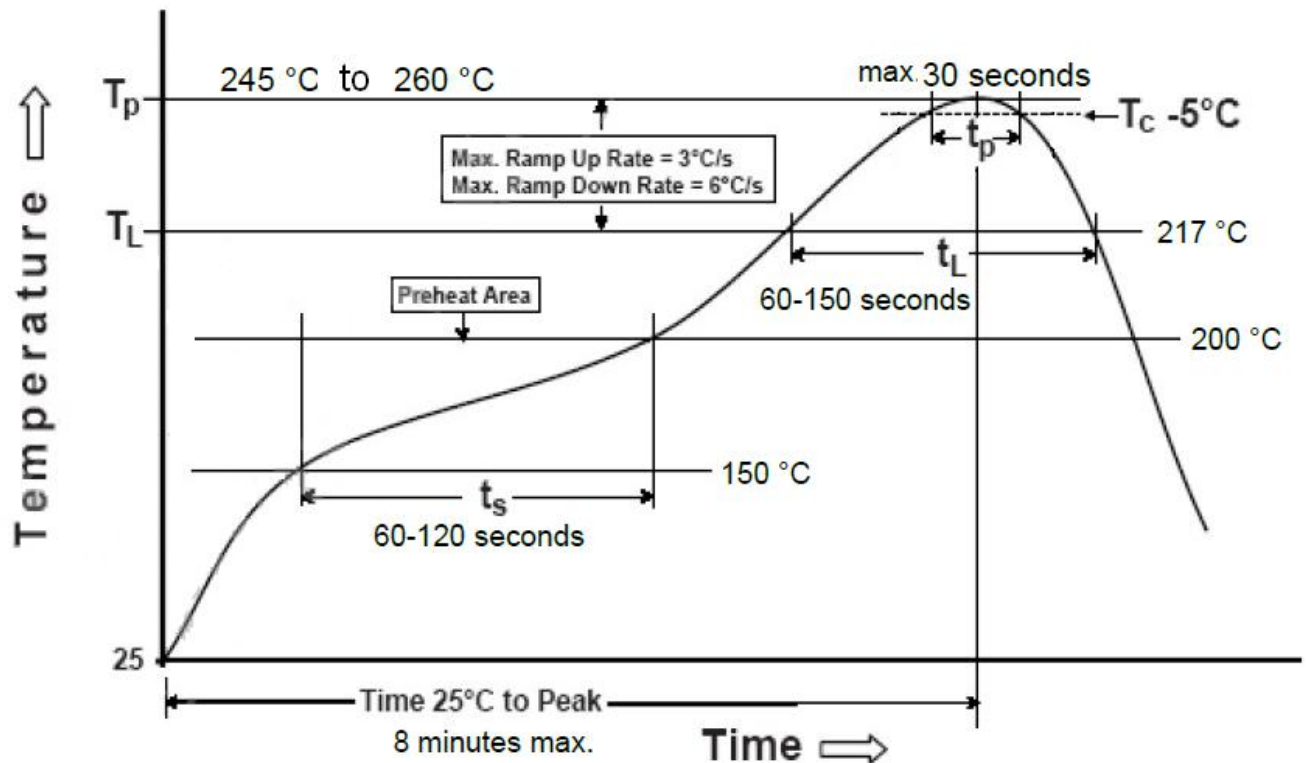

Figure 7: SKG09A Typical Leadfree Soldering Profile

Note : The final soldering temperature chosen at the factory depends on additional external factors like choice of soldering paste, size, thickness and properties of the baseboard, etc. Exceeding the maximum soldering temperature in the recommended soldering profile may permanently damage the module.

14 Software Protocol

NMEA 0183 Protocol

The NMEA protocol is an ASCII-based protocol, Records start with a \$ and with carriage return/line feed. GPS specific messages all start with \$GPxxx where xxx is a three-letter identifier of the message data that follows. NMEA messages have a checksum, which allows detection of corrupted data transfers.

The Skylab SKG09A supports the following NMEA-0183 messages: GGA, GLL, GSA, GSV, RMC VTG, ZDA.

The module default NMEA-0183 output is set up GGA、GSA、RMC、GSV , and default baud rate is set up 9600bps.

Table 1: NMEA-0183 Output Messages

NMEA Record	Description	Default
GGA	Global positioning system fixed data	Y
GLL	Geographic position—latitude/longitude	N
GSA	GNSS DOP and active satellites	Y
GSV	GNSS satellites in view	Y
RMC	Recommended minimum specific GNSS data	Y
VTG	Course over ground and ground speed	N
ZDA	Date and Time	N

GGA-Global Positioning System Fixed Data

This sentence contains the position, time and quality of the navigation fix.

See RMC for Fix Status, Fix Mode, Fix Date, Speed, and True Course.

See GSA for Fix Type, PDOP, and VDOP.

\$GPGGA,021514.000,2232.1799,N,11401.1823,E,1,6,1.25,84.0,M,-2.2,M,,*74

Table 2: GGA Data Format

Name	Example	Units	Description
Message ID	\$GPGGA		GGA protocol header
UTC Position	021514.000		hhmmss.sss
Latitude	2232.1799		ddmm.mmmm

N/S indicator	N		N=north or S=south
Longitude	11401.1823		dddmm.mmmm
E/W Indicator	E		E=east or W=west
Position Fix Indicator	1		See Table 2-1
Satellites Used	6		Range 0 to 12
HDOP	1.25		Horizontal Dilution of Precision
MSL Altitude	84.0	meters	Altitude (referenced to the Ellipsoid)
AltUnit	M	meters	Altitude Unit
GeoSep	-2.2	meters	Geoidal Separation
GeoSepUnit	M	meters	Geoidal Separation Unit
Age of Diff.Corr.	<Null>	second	Null fields when it is not Used
Diff.Ref.Station ID	<Null>		Null fields when it is not Used
Checksum	*74		
EOL	<CR> <LF>		End of message termination

Table 2-1: Position Fix Indicators

Value	Description
0	Fix not available or invalid
1	GPS SPS Mode, fix valid
2	Differential GPS, SPS Mode, fix valid
3	GPS PPS Mode, fix valid

GLL-Geographic Position – Latitude/Longitude

This sentence contains the fix latitude and longitude.

\$GPGLL,2232.1799,N,11401.1824,E,021513.000,A,A*50

Table 3: GLL Data Format

Name	Example	Units	Description
Message ID	\$GPGLL		GLL protocol header
Latitude	2232.1799		ddmm.mmmm
N/S Indicator	N		N=north or S=south
Longitude	11401.1824		dddmm.mmmm
E/W Indicator	E		E=east or W=west

UTC Position	021513.000		hhmmss.sss
Fix Status	A		A=data valid or V=data not valid
Fix Mode	A		A=autonomous, N = No fix, D=DGPS, E=DR
Checksum	*50		
EOL	<CR> <LF>		End of message termination

GSA-GNSS DOP and Active Satellites

This sentence contains the mode of operation, type of fix, PRNs of the satellites used in the solution as well as PDOP, HDOP and VDOP.

\$GPGSA,A,3,26,05,18,15,27,29,,,,,1.52,1.25,0.87*0F

Table 4: GSA Data Format

Name	Example	Units	Description
Message	\$GPGSA		GSA protocol header
Mode 1	A		See Table 4-2
Mode 2	3		See Table 4-1
ID of satellite used	26		Sv on Channel 1
ID of satellite used	05		Sv on Channel 2
...
ID of satellite used	<Null>		Sv on Channel 12 (Null fields when it is not Used)
PDOP	1.52		Position Dilution of Precision
HDOP	1.25		Horizontal Dilution of Precision
VDOP	0.87		Vertical Dilution of Precision
Checksum	*0F		
EOL	<CR> <LF>		End of message termination

Table 4-1: Mode 1

Value	Description
1	Fix not available
2	2D Fix
3	3D Fix

Table 4-2: Mode 2

Value	Description
M	Manual-forced to operate in 2D or 3D mode
A	Automatic-allowed to automatically switch 2D/3D

GSV-GNSS Satellites in View

This sentence contains the PRNs, azimuth, elevation, and signal strength of all satellites in view.

\$GPGSV,3,1,12,15,79,333,42,42,50,127,,29,45,263,44,02,36,124,30*7E

\$GPGSV,3,2,12,26,36,226,34,05,35,046,22,27,33,161,29,21,16,319,*7D

\$GPGSV,3,3,12,10,15,066,31,18,14,285,45,24,12,319,15,08,09,047,18*7E

Table 5: GSV Data Format

Name	Example	Units	Description
Message ID	\$GPGSV		GSV protocol header
Number of Message	3		Total number of GSV sentences (Range 1 to 3)
Message Number	1		Sentence number of the total (Range 1 to 3)
Satellites in View	12		Number of satellites in view
Satellite ID	15		Channel 1(Range 01 to 32)
Elevation	79	degrees	Channel 1(Range 00 to 90)
Azinmuth	333	degrees	Channel 1(Range 000 to 359)
SNR(C/NO)	42	dB-Hz	Channel 1(Range 00 to 99, null when not tracking)
...			...
Satellite ID	02		Channel 4(Range 01 to 32)
Elevation	36	degrees	Channel 4(Range 00 to 90)
Azimuth	124	degrees	Channel 4(Range 000 to 359)
SNR(C/NO)	30	dB-Hz	Channel 4(Range 00 to 99, null when not tracking)
Checksum	*7E		
EOL	<CR> <LF>		End of message termination

Depending on the number of satellites tracked multiple messages of GSV data may be required.

RMC-Recommended Minimum Specific GNSS Data

This sentence contains the recommended minimum fix information.

See GGA for Fix Quality, Sats Used, HDOP, Altitude, Geoidal Separation, and DGPS data.

See GSA for Fix Type, PDOP and VDOP.

\$GPRMC,023345.000,A,2232.1767,N,11401.1953,E,0.18,151.55,100410,,,A*6B

Table 6: RMC Data Format

Name	Example	Units	Description
Message ID	\$GPRMC		RMC protocol header
UTS Position	023345.000		hhmmss.sss
Status	A		A=data valid or V=data not valid
Latitude	2232.1767		ddmm.mmmm
N/S Indicator	N		N=north or S=south
Longitude	11401.1953		dddmm.mmmm
E/W Indicator	E		E=east or W=west
Speed Over Ground	0.18	Knots	
Course Over Ground	151.55	Degrees	True Course
Date(UTC)	100410		ddmmyy
Magnetic variation	<Null>	Degrees	Null fields when it is not Used
Magnetic Variation Direction	<Null>		E=east or W=west (Null fields when it is not Used)
Fix Mode	A		A=autonomous, N = No fix, D=DGPS, E=DR
Checksum	*6B		
EOL	<CR> <LF>		End of message termination

VTG-Course Over Ground and Ground Speed

This sentence contains the course and speed of the navigation solution.

\$GPVTG,148.81,T,,M,0.13,N,0.24,K,A*3D

Table 7: VTG Data Format

Name	Example	Units	Description
Message ID	\$GPVTG		VTG protocol header
Tcourse	148.81	Degrees	True Course
Reference	T		T = True
Mcourse	<Null>	Degrees	Magnetic Course (Null fields when it is not Used)
Reference	M		M = Magnetic (Null fields when it is not Used)
Speed over ground	0.13	Knots	Nautical Miles per Hour
Units	N		Knots
Speed over ground	0.24	Km/hr	in Kilometers per Hour
Units	K		Kilometer per hour
Mode	A		A=Autonomous, N=No fix, D=DGPS, E=DR
Checksum	*3D		
EOL	<CR> <LF>		End of message termination

ZDA-Date and Time

This sentence contains UTC date & time, and local time zone offset information.

\$GPZDA,023345.000,10,04,2010,*,*50

Table 8: ZDA Data Format

Name	Example	Units	Description
Message ID	\$GPZDA		ZDA protocol header
UTC Time	023345.000		hhmmss.sss
Day	10		UTC time: day (01 ... 31) dd
Month	04		UTC time: month (01 ... 12) mm
Year	2010		UTC time: year (4 digit year) yyyy
local zone hours	<null>		Local Time Zone Offset Hours (Null fields when it is not Used)
local zone minutes	<null>		Local Time Zone Offset Minutes (Null fields when it is not Used)
Checksum	*50		
EOL	<CR> <LF>		End of message termination

CMD List

CMD TYPE	CMD Example:
Hot Restart	\$PMTK101*32<CR><LF>
Warm Restart	\$PMTK102*31<CR><LF>
Cold Restart	\$PMTK103*30<CR><LF>
Full Cold Restart	\$PMTK104*37<CR><LF>
FLP Mode	\$PMTK262,1*29<CR><LF>

15 Contact Information

Skylab M&C Technology Co., Ltd.

深圳市天工测控技术有限公司

Address: 6 Floor, No.9 Building, Lijincheng Scientific & Technical park, Gongye East Road,
Longhua District, Shenzhen, Guangdong, China

Phone: 86-755 8340 8210 (Sales Support)

Phone: 86-755 8340 8510 (Technical Support)

Fax: 86-755-8340 8560

E-Mail: technicalsupport@skylab.com.cn

Website: www.skylab.com.cn www.skylabmodule.com