

SKB362 Bluetooth 4.0 Low Energy Module Datasheet

Document Information	
Title	SKB362 Bluetooth 4.0 Low Energy Module Datasheet
Document type	Datasheet
Document number	SL-19120144
Revision and date	V3.04 19-Dec-2019
Disclosure restriction	Public

Revision History

Revision	Description	Approved	Date
V1.01	Initial Release	Sunny	20140811
V2.01	Add AT Instruction	Sunny	20150528
V2.02	Add Power consumption	Sunny	20150617
V3.01	Upgrade Format	Hogan	20161211
V3.02	Upgrade Hardware	Hogan	20170321
V3.03	Update certification information	George	20170831
V3.04	Update Transmit Power	George	20191219

SKYLAB reserves all rights to this document and the information contained herein. Products, names, logos and designs described herein may in whole or in part be subject to intellectual property rights. Reproduction, use, modification or disclosure to third parties of this document or any part thereof without the express permission of SKYLAB is strictly prohibited.

The information contained herein is provided “as is” and SKYLAB assumes no liability for the use of the information. No warranty, either express or implied, is given, including but not limited, with respect to the accuracy, correctness, reliability and fitness for a particular purpose of the information. This document may be revised by SKYLAB at any time. For most recent documents, visit www.skylab.com.cn.

Copyright © 2018, Skylab M&C Technology Co., Ltd.

SKYLAB® is a registered trademark of Skylab M&C Technology Co., Ltd in China

Contents

Contents.....	3
1. General Description.....	4
2. Applications.....	4
3. Features.....	5
4. Application Block Diagram.....	6
5. Interfaces.....	7
5.1 Power Supply.....	7
5.2 System Function Interfaces.....	7
5.2.1 GPIOs.....	7
5.2.2 Two-wire Interface (I2C Compatible).....	7
5.2.3 Flash Program I/Os.....	8
5.2.4 Serial Peripheral Interface.....	8
5.2.5 UARTs.....	8
5.2.6 Analog to Digital Converter (ADC).....	9
5.2.7 Low Power Comparator (LPCOMP).....	9
5.2.8 Reset.....	9
6. Module Specifications.....	10
7. Module Pinout and Pin Description.....	11
7.1 Module Pinout.....	11
7.2 Pin Description.....	12
8. PCB Design Guide.....	12
9. PCB Footprint and Dimensions.....	13
10. Electrical Characteristics.....	14
10.1 Absolute Maximum Ratings.....	14
10.2 Recommended Operation Ratings.....	14
10.3 Current.....	14
11. Manufacturing Process Recommendations.....	15
12. Ordering Information.....	15
13. Packaging Specification.....	16
14. Contact Information.....	16

1. General Description

The SKB362 is a highly integrated Bluetooth 4.0 BLE module, designed for high data rate, short-range wireless communication in the 2.4GHz ISM band. The module is based on Nordic nRF51822 radio Transceiver IC, has a 32 bit ARM Cortex-M0 CPU, Flash memory and analog and digital peripherals. The SKB362 provides a low power and ultra-low cost BLE solution for wireless transmission applications.

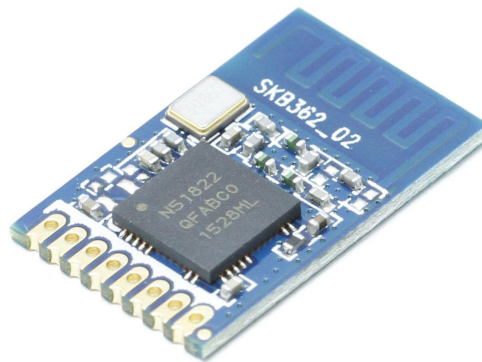

Figure 1: SKB362 Top View

2. Applications

- ◆ Computer peripherals and I/O devices
 - Mouse
 - Keyboard
 - Multi-touch trackpad
- ◆ Interactive entertainment devices
 - Remote control
 - 3D Glasses
 - Gaming controller
- ◆ Personal Area Networks
 - Health/fitness sensor and monitor devices
 - Medical devices
 - Key-fobs + wrist watches
- ◆ Remote control toys

- ◆ Beacons
- ◆ Bluetooth Gateway
- ◆ Indoor Location
- ◆ Colourful LED Control

3. Features

- ◆ Main Chip: nRF51822
- ◆ Bluetooth® 4.0 low energy single-mode protocol stack
 - L2CAP, ATT, GAP, GATT and SM protocols
 - Central and Peripheral roles
 - GATT Client and Server
 - Full SMP support including MITM and OOB pairing
- ◆ Data rates up to 1Mbps
- ◆ 8/9/10 bit ADC-1 configurable channels
- ◆ 4 General Purpose I/O pins
- ◆ SPI Master/Slave
- ◆ Two-wire Master (I2C compatible)
- ◆ UART (CTS/RTS)
- ◆ CPU independent Programmable Peripheral Interconnect (PPI)
- ◆ Quadrature Decoder (QDEC)
- ◆ AES HW encryption
- ◆ RoHS compliance (Lead-free)
- ◆ CE,FCC compliance

4. Application Block Diagram

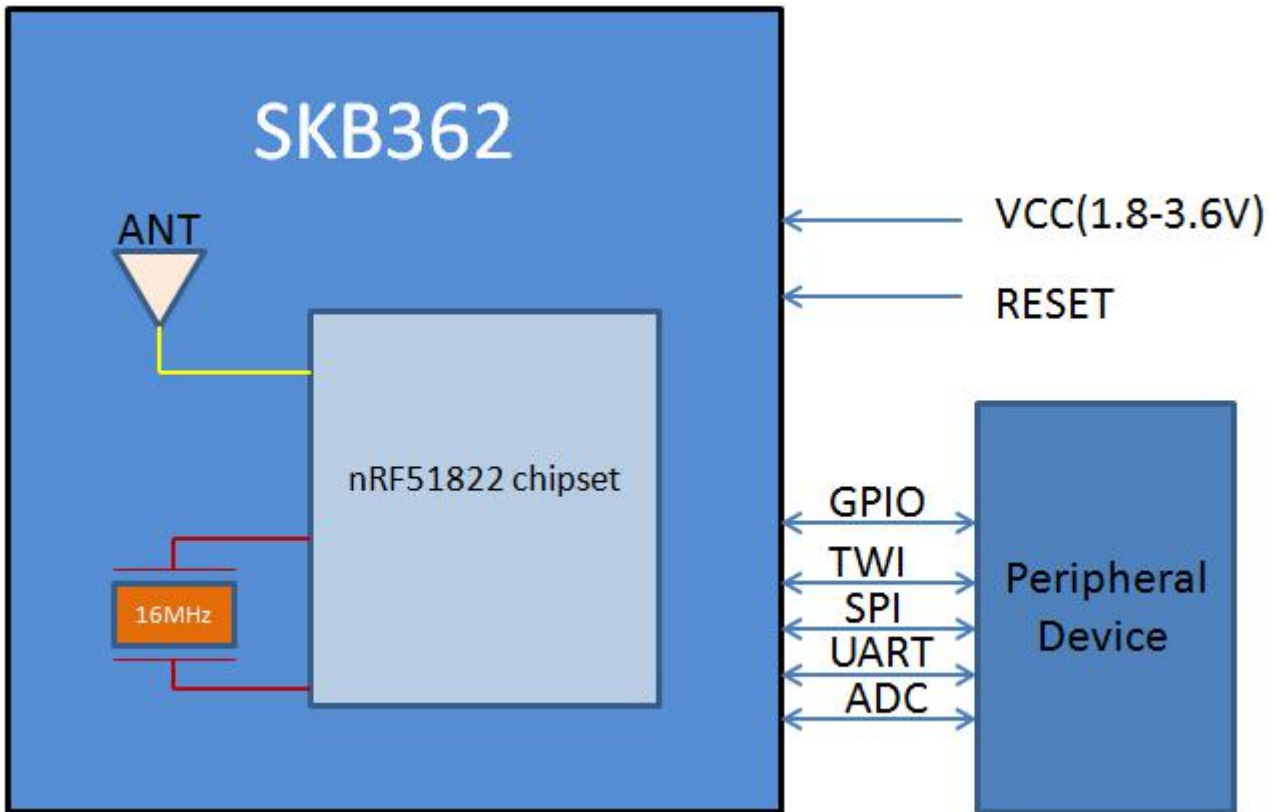

Figure 2: SKB362 Block Diagram

5. Interfaces

5.1 Power Supply

Regulated power for the SKB362 is required. The input voltage Vcc range should be 1.8V to 3.6V, current is not less than 20mA. Suitable decoupling must be provided by external decoupling circuitry (10uF and 0.1uF). It can reduce the noise from power supply and increase power stability.

5.2 System Function Interfaces

5.2.1 GPIOs

The general purpose I/O is organized as one port with up to 4 I/Os enabling access and control of up to 4 pins through one port. Each GPIO can be accessed individually with the following user configurable features:

- 1、 Input/output direction
- 2、 Output drive strength
- 3、 Internal pull-up and pull-down resistors
- 4、 Wake-up from high or low level triggers on all pins
- 5、 Trigger interrupt on all pins
- 6、 All pins can be used by the PPI task/event system; the maximum number of pins that can be interfaced through the PPI at the same time is limited by the number of GPIOTE channels
- 7、 All pins can be individually configured to carry serial interface or quadrature demodulator signals
- 8、 All pins can be configured as PWM signal
- 9、 There are 1 ADC/LPCOMP input in the 4 I/Os

5.2.2 Two-wire Interface (I2C Compatible)

The two-wire interface can communicate with a bi-directional wired-AND bus with two lines (SCL, SDA). The protocol makes it possible to interconnect up to 127 individually addressable devices. The interface is capable of clock stretching, supporting data rates of 100 kbps and 400 kbps. The module has 2 TWI ports and they properties like following table.

Instance	Master/Slave
TWI0	Master
TWI1	Master

Table5-1: TWI Pin Share Scheme

Note: I2C:Inter – Integrated Circuit

5.2.3 Flash Program I/Os

The module has two programmer pins, respectively SWDCLK pin and SWDIO pin. The two pin Serial Wire Debug (SWD) interface provided as a part of the Debug Access Port (DAP) offers a flexible and powerful mechanism for non-intrusive debugging of program code. Breakpoints and single stepping are part of this support.

SWDIO can also be used as system reset pin, the system reset pin is active low.

5.2.4 Serial Peripheral Interface

The SPI interfaces enable full duplex synchronous communication between devices. They support a three-wire (SCK, MISO, MOSI) bi-directional bus with fast data transfers. The SPI Master can communicate with multiple slaves using individual chip select signals for each of the slave devices attached to a bus. Control of chip select signals is left to the application through use of GPIO signals. SPI Master has double buffered I/O data. The SPI Slave includes EasyDMA for data transfer directly to and from RAM allowing Slave data transfers to occur while the CPU is IDLE. The GPIOs are used for each SPI interface line can be chosen from any GPIOs on the device and configed independently. This enables great flexibility in device pinout and efficient use of printed circuit board space and signal routing.

The SPI peripheral support SPI mode 0,1,2,and 3.The module have 3 SPI ports and theirs they properties are as below:

Instance	Master/Slave
SPI0	Master
SPI1	Master
SPIS1	Slave

Table5-2: SPI Properties

5.2.5 UARTs

The Universal Asynchronous Receiver/Transmitter offers fast, full-duplex, asynchronous serial communication with built-in flow control (CTS, RTS), support in hardware up to 1 Mbps baud. Parity checking is supported.

The default P0.09 is UART_TX, P0.011 is UART_RX. Support the following baudrate in bps unit:

1200/2400/4800/9600/14400/19200/28800/38400/57600/76800/115200.

SKB362 Pin Number	Pin Name	UART	Pin Share
4	P0.09	UART_TX	UART(For Debug)

5	P0.11	UART_RX	
---	-------	---------	--

Table5-3: UART Pin Share Scheme

Note: The GPIOs are used for each SPI/TWI/UART interface line can be chosen from any GPIOs on the device and configed independently.

5.2.6 Analog to Digital Converter (ADC)

The 10 bit incremental Analog to Digital Converter (ADC) enables sampling of up to 8 external signals through a front-end multiplexer. The ADC has configurable input and reference prescaling, and sample resolution (8, 9, and 10 bit).

Note: The ADC module uses the same analog inputs as the LPCOMP module. Only one of the modules can be enabled at the same time.

SKB362 Pin Number	Pin Number	Description
3	P0.01	Digital I/O; Analog input 2

Table5-4: ADC Pins

5.2.7 Low Power Comparator (LPCOMP)

In System ON, the block can generate separate events on rising and falling edges of a signal, or sample the current state of the pin as being above or below the threshold. The block can be configured to use any of the analog inputs on the device. Additionally, the low power comparator can be used as an analog wakeup source from System OFF or System ON. The comparator threshold can be programmed to a range of fractions of the supply voltage.

5.2.8 Reset

The reset pin of the SKB362 module is in the internal pull-high state , when the reset pin of the module is input to a low level , the module will be automatically reset .After the reset pin is used , the parameters of the current setting will not be reserved .

6. Module Specifications

Hardware Features	
Model	SKB362
Antenna Type	PCB Antenna
Chipset Solution	nRF51822
Voltage	1.8V~3.6V
Dimension(L×W×H)	12×19×1.9 mm
Wireless Features	
Wireless Standards	Bluetooth ® 4.0
Frequency Range	2400MHz---2483.5MHz
Data Rates	1Mbps
Modulation Technique	GFSK Modulation
Wireless Security	AES HW Encryption
Transmit Power	Tx Power -30, -20, -16, -12, -8, -4, 0, and 4 dBm
Work Mode	Central/Peripheral
Others	
Certification	RoHS
Environment	Operating Temperature: -25℃~75℃
	Storage Temperature: -40℃~85℃
	Operating Humidity: 10%~90% Non-condensing
	Storage Humidity: 5%~90% Non-condensing

7. Module Pinout and Pin Description

7.1 Module Pinout

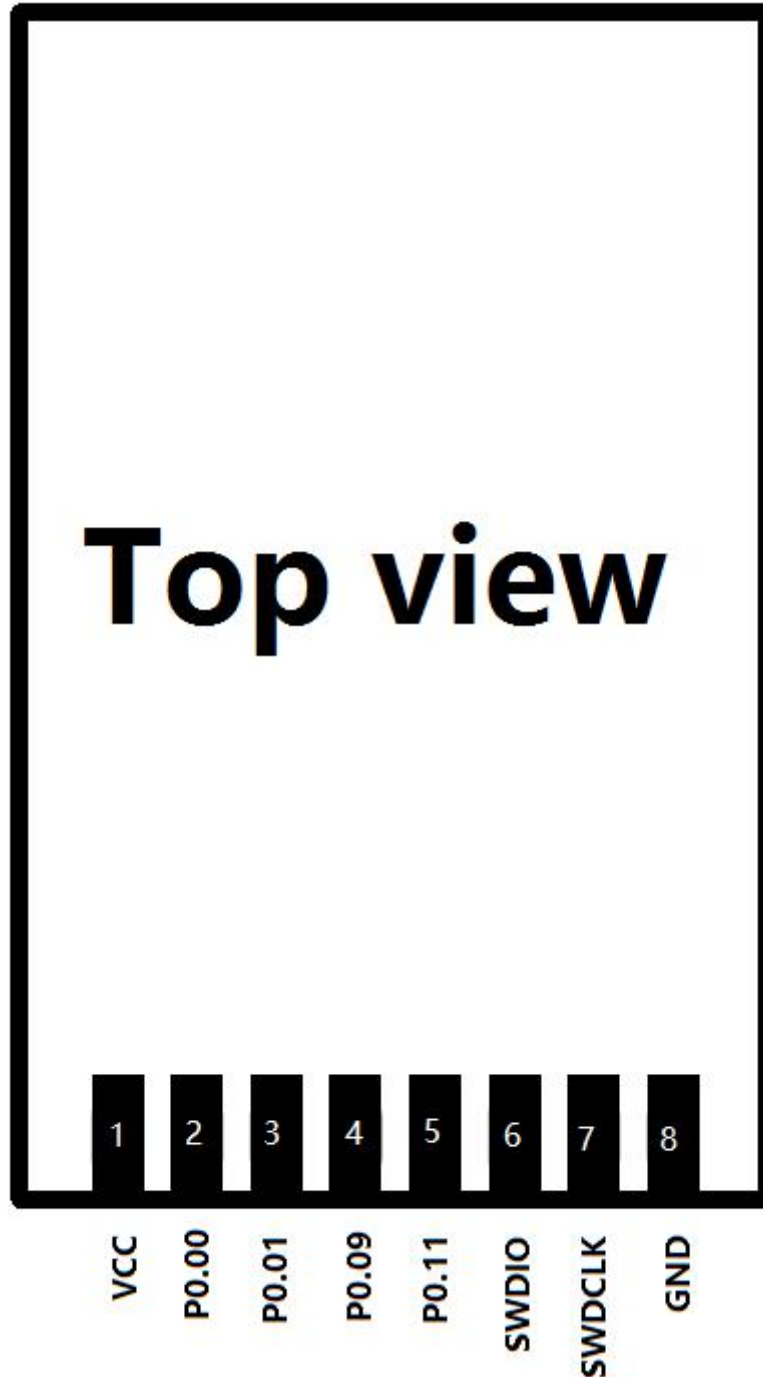

Figure 3: SKB362 Module Pinout

7.2 Pin Description

Pin No.	Pin Name	Description	Remark
1	VCC	Main Power Supply	1.8V to 3.6V
2	P0.00	Digital I/O; Analog input	ADC/LPCOMP reference input 0
3	P0.01	Digital I/O; Analog input	ADC/LPCOMP input 2
4	P0.09	General Purpose I/O	Default UART TX
5	P0.11	General Purpose I/O	Default UART RX
6	SWDIO/nRESET	Hardware Debug and Flash Program I/O; System Reset (Active low)	Digital I/O
7	SWDCLK	Hardware debug and Flash program I/O	Digital input
8	GND	Ground	

Note: The P0.00 can be used to ADC/LPCOMP reference input 0, ADC/LPCOMP reference input 0 voltage range is 0.83V to 1.3V, the typical value is 1.2V.

8. PCB Design Guide

Please reserve empty area for PCB antenna when you are going to design a device's board, the empty range minimum size :

15*8.3mm , please kindly check the "PCB footprint and Dimensions" for reference.

9. PCB Footprint and Dimensions

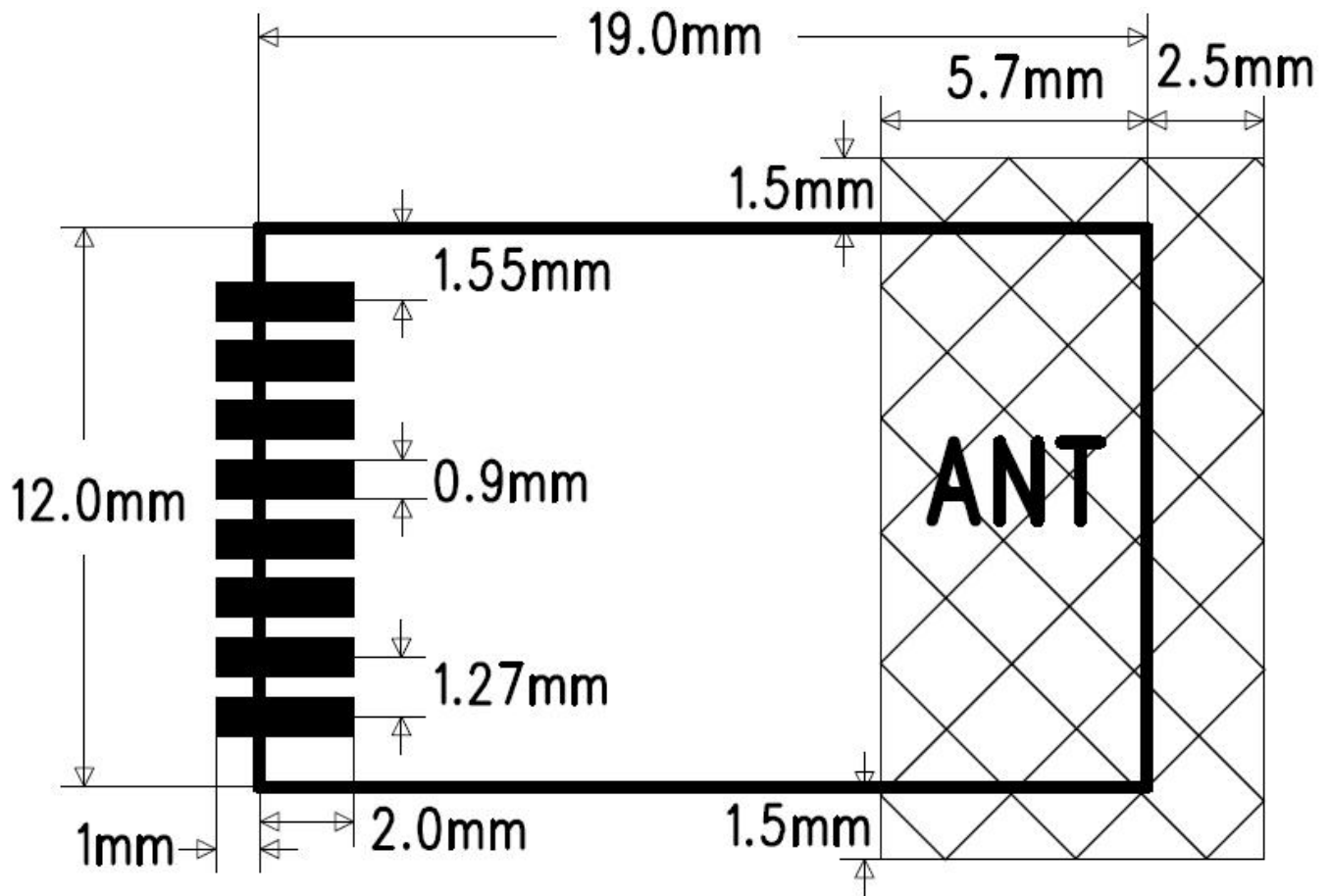

Figure 4: SKB362 Recommended PCB Footprint

10. Electrical Characteristics

10.1 Absolute Maximum Ratings

Parameter	Condition	Min.	Typ.	Max.	Unit
Storage Temperature Range		-40		85	°C
ESD Protection	VESD	/		4000	V
Supply Voltage	VCC	-0.3		3.9	V
Voltage On Any I/O Pin		-0.3		3.63	V

Table10-1: Absolute Maximum Ratings

10.2 Recommended Operation Ratings

Parameter	Symbol	Min.	Typ.	Max.	Unit
Extended Temp. Range	TA	-25		75	°C
Power Supply	VCC	1.8	3.3	3.6	V
Input Low Voltage	VIL	0		1	V
Input High Voltage	VIH	2.3		3.9	V

Table10-2: Operating Conditions

10.3 Current

System State	TX Peak @0dBm	RX Peak	Advertise Interval @100ms (0dBm)(avg)	Sleep Mode (avg)	Idle Mode (avg)
Current (peak)@3V	10.5 mA	13 mA	270uA	0.28uA	2.43uA

Table10-3: Power Consumption in Different States

11. Manufacturing Process Recommendations

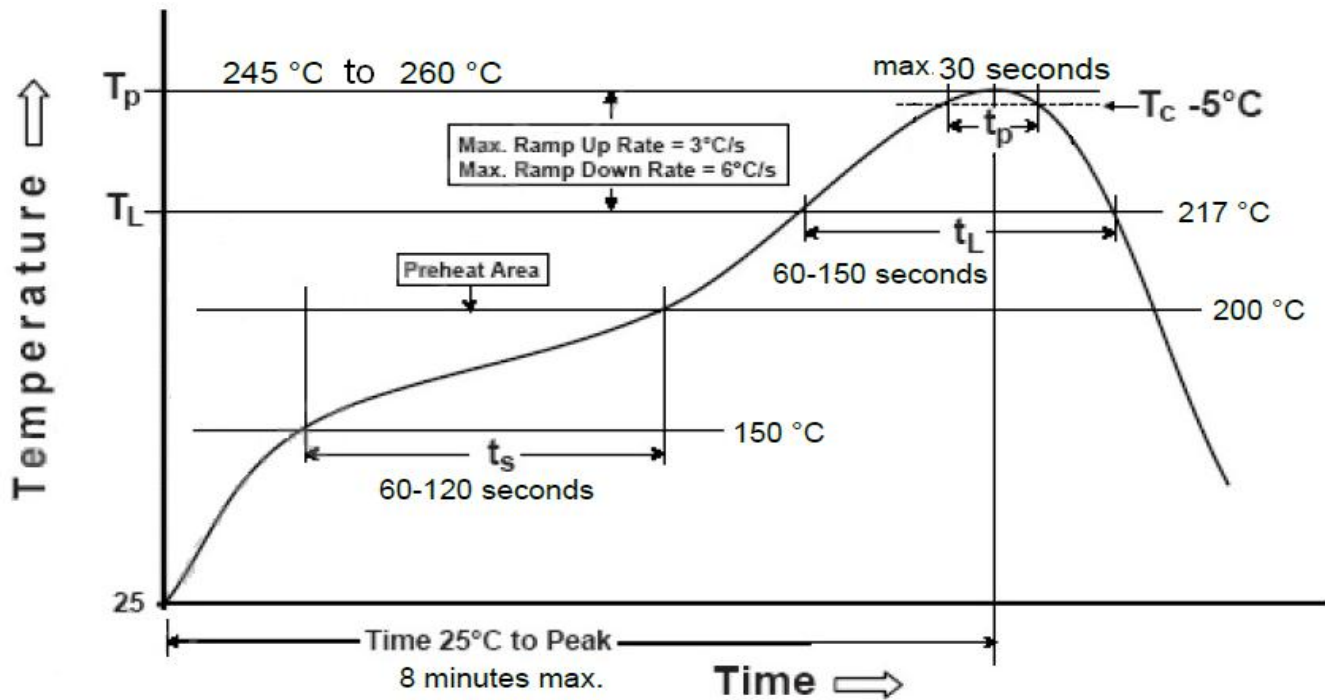

Figure 5: SKB362 Typical Lead-free Soldering Profile

Note: The final re-flow soldering temperature map chosen at the factory depends on additional external factors, for example, choice of soldering paste, size, thickness and properties of the module's baseboard etc. Exceeding the maximum soldering temperature in the recommended soldering profile may permanently damage the module.

12. Ordering Information

Module No.	Description	Remarks
SKB362	Bluetooth 4.0 Low Energy Module	Have No 32.768KHz Crystal On The Module
SKB362C	Bluetooth 4.0 Low Energy Module	Have 32.768KHz Crystal On The Module

Note: The SKB362C module can be used 32.768KHZ crystal as the clock source of protocol stack, in this case, the RTC clock precision is higher, and the power consumption is lower. SKB362 module without 32.768KHZ, so can only be configured using the internal oscillator as a clock source, low precision, and needs to be calibrated regularly, calibration of the average power consumption increased 100uA. the average power consumption increased 100uA when calibration the module.

13. Packaging Specification

The SKB362 module are put into the tray with 66 units per tray, The 8 trays are packed in a dry, vacuum package , and packed in a box. Four boxes into a carton.

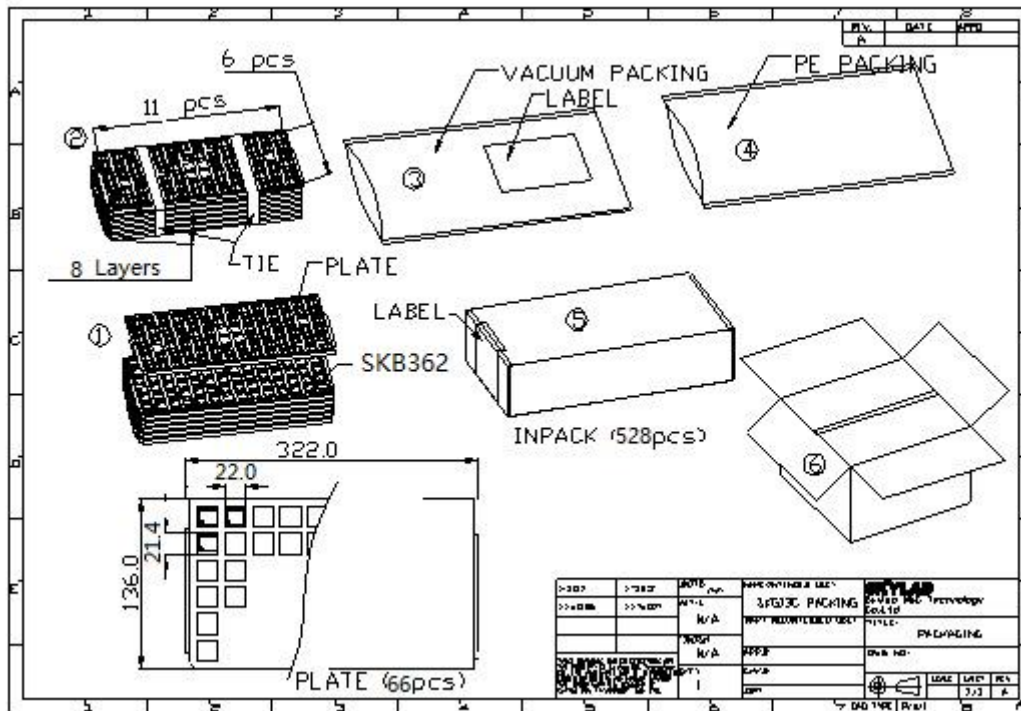

Figure 6: SKB362 Packaging

14. Contact Information

Skylab M&C Technology Co., Ltd.

深圳市天工测控技术有限公司

Address: 6 Floor, No.9 Building, Lijincheng Scientific & Technical park, Gongye East Road,
Longhua District, Shenzhen, Guangdong, China

Phone: 86-755 8340 8210 (Sales Support)

Phone: 86-755 8340 8510 (Technical Support)

Fax: 86-755-8340 8560

E-Mail: sales1@skylab.com.cn

Website: www.skylab.com.cn www.skylabmodule.com