

# SKG122ER 规格书 GNSS模块 SKG122ER Datasheet GNSS Module

## 文档信息/Document information

标题/Title	SKG122ER 规格书 GNSS 模块	
	SKG122ER Datasheet GNSS Module	
文档类型/Document type	规格书/Datasheet	
文档编号/Document number	SL-22030227	
修订和日期/Revision and date	V1.01	24-Mar-2022
公开限制/Disclosure restriction	公开/ Public	

## 版本历史/Revision History

版本/Version	描述/Description	制定/Make	日期/Date
V1.01	初始版本/Initial version	Wilson	20220324

SKYLAB 保留本文档及本文档所包含的信息的所有权利。SKYLAB 拥有本文档所述的产品、名称、标识和设计的全部知识产权。严禁没有征得 SKYLAB 的许可的情况下复制、使用、修改或向第三方披露本文档的全部或部分内容。

SKYLAB 对本文档所包含的信息的使用不承担任何责任。没有明示或暗示的保证，包括但不限于关于信息的准确性、正确性、可靠性和适用性。SKYLAB 可以随时修订这个文档。可以访问 [www.skylab.com.cn](http://www.skylab.com.cn) 获得最新的文件。

Copyright © 2022, 深圳市天工测控技术有限公司。

SKYLAB® 是深圳市天工测控技术有限公司在中国的注册商标。

SKYLAB reserves all rights to this document and the information contained herein. Products, names, logos and designs described herein may in whole or in part be subject to intellectual property rights. Reproduction, use, modification or disclosure to third parties of this document or any part thereof without the express permission of SKYLAB is strictly prohibited.

The information contained herein is provided “as is” and SKYLAB assumes no liability for the use of the information. No warranty, either express or implied, is given, including but not limited, with respect to the accuracy, correctness, reliability and fitness for a particular purpose of the information. This document may be revised by SKYLAB at any time. For most recent documents, visit [www.skylab.com.cn](http://www.skylab.com.cn).

Copyright © 2020, Skylab M&C Technology Co., Ltd.

SKYLAB® is a registered trademark of Skylab M&C Technology Co., Ltd in China

## 目录

1 产品简介/Product Introduction.....	5
2 典型应用/Applications.....	5
3 产品特点/Product Feature.....	6
4 性能参数/Performance Parameter.....	6
5 PIN 脚定义/ PIN Definition.....	8
6 电气特性/Electrical Characteristics.....	10
6.1 极限值/limit value.....	10
6.2 运行条件/Operating Condition.....	10
7 传输及外设接口/Transport And Peripheral Interface.....	11
7.1 PPS.....	11
7.2 I2C（预留，可定制）/ I2C (Reserved, Customizable).....	11
7.3 UART.....	11
7.4 GPIO（预留，可定制）/ GPIO(Reserved, Customizable).....	11
7.5 EXTINT（预留，可定制）/ EXTINT(Reserved, Customizable).....	11
7.6 SPI（预留，可定制）/ SPI(Reserved, Customizable).....	12
7.7 USB（预留，可定制）/ USB(Reserved, Customizable).....	12
8 默认配置/ Default Configuration.....	12
9 天线开短路检测/ Antenna Disconnection And Short-circuit Detection.....	13
10 软件说明/Software Specifications.....	14
10.1 NMEA 0183 协议/ NMEA 0183 Protocol.....	14
10.2 GGA -定位数据信息/ GGA - Location Data Information.....	15
10.3 GSA -当前卫星信息/ GSA - Current satellite information.....	16
10.4 GSV -可见卫星信息/ GSV - Visible satellite information.....	17
10.5 RMC -推荐定位信息/ RMC - Recommended Location Information.....	18
10.6 ZDA - 时间日期信息/ ZDA - Time and date information.....	19
10.7 TXT -天线检测信息/ TXT - Antenna detection information.....	19
11 机械尺寸/Machine Dimension.....	21
11.1 Layout 注意事项.....	22

12 包装规格.....	24
13 贴片建议.....	25
14 参考电路.....	26
15 联系方式/ Contact Information.....	26

## 1 产品简介/Product Introduction

SKG122ER 是一款高性能的 RTK 导航定位模块，模块能同时支持 GPS、北斗、GLONASS、GALILEO、QZSS 和 SBAS 的卫星接收模块，拥有定位快，精度高，产品性能可靠的优点。

SKG122ER is a high-performance RTK positioning module, which can support GPS, Beidou, GLONASS satellite signal reception. It has the advantages of fast positioning, high precision and reliable product performance.

该模组集成了内部 RTK 解算算法，结合 RTK 服务可实现厘米级定位。通过配置可以使模组变为移动站。能满足专业定位的严格要求与个人消费需要。

The module integrates the internal RTK algorithm and implements centimeter level positioning with RTK service. Modules can be configured to become mobile stations. To meet the strict requirements of professional positioning and personal consumption needs.

外形尺寸紧凑，兼容市场上国际主流导航定位模块，采用 SMD 焊盘，支持标准取放及回流焊接。The module is compact in shape, compatible with the international mainstream navigation and positioning modules in the market, using SMD pad, support standard take and put and reflow welding.



图 1: SKG122ER 正视图

## 2 典型应用/Applications

- ◆ 汽车导航/ Auto navigation
- ◆ 个人导航设备/ Personal navigation equipment
- ◆ 汽车保全系统/ Car Security System
- ◆ 车辆监控/ Vehicle monitoring

### 3 产品特点/Product Feature

- ◆ 支持 BDS、GPS、GLONASS、Galileo、QZSS 系统/ Supports BDS, GPS, GLONASS, Galileo, QZSS systems
- ◆ 极快的 TTFF：冷启动小于 28s；热启动小于 1s / Extremely fast TTFF: cold start less than 28s; Hot start less than 1s
- ◆ 高度集成 RTK，可实现厘米级定位精度/Integrated with RTK real-time dynamic technology, centimeter positioning accuracy can be achieved.
- ◆ 内置有源天线保护功能/Built-in active antenna protection function
- ◆ 工业级标准/Industrial Grade Standards
- ◆ 超小尺寸/Super small size: 16.0x12.2x2.4mm
- ◆ 符合 RoHS, FCC, CE 标准/Compliance with RoHS, FCC, CE standards
- ◆ 获得最快的定位时间/Get the fastest location time
- ◆ 弱信号下较好的定位精度和位置有效性/Better positioning accuracy and position validity are maintained under weak signal
- ◆ 优越的质量和可靠性/Superior quality and reliability

### 4 性能参数/Performance Parameter

表 4-1 基本参数/ Table 4-1 Basic parameters

参数 /Parameter	描述/Description	性能指标/ Performance Evaluation
电压/Voltage		3.0~3.6V
GNSS 追踪通道 //GNSS trace channel		40
射频输入/ RF Input	频率/Frequency	GPS/QZSS :L1CA GLONASS: L1 BeiDou: B1I GALILEO: E1 SBAS:WAAS,EGNOS,MSAS,GAGAN,SDCM
	驻波比 /Standing-wave ratio	≤1.5
	输入阻抗/ Input impedance	50Ω±10%

	天线增益/ Antenna Gain	0~32dB
物理尺寸 /Physical Size		16.0*12.2*2.4 (单位: mm)
数据接口/ Data interface		1 个 UART, TTL 电平,波特率 1200~460800bps 可调, 默认 115200/ One UART, TTL level, baud rate adjustable from 1200 to 460800bps, 115200 by default
天线检测/ Antenna testing		具备天线检测功能/With antenna detection function

表 4-2 GNSS 性能指标/ Table 4-2 GNSS performance specifications

参数/Parameter	描述/Description	性能指标/ Performance Evaluation
首次定位时间 TTFF/ First positioning time TTFF	冷启动/Cold Start	≤28s
	热启动/Hot Start	≤1s
	重捕获/Re-Acquisition	≤1s
灵敏度/Sensitivity	跟踪/Tracking	-162dBm
	捕获/Acquisition	-148dBm
精度/precision	GNSS 定位/Position	Open-Sky CEP=2.5m
	RTK	2.5cm+1ppm(H)
	D-GNSS	<1m CEP
	1PPS	20ns
	速度/Speed	0.1m/s
动态性能/dynamic performance	速度/Speed	515m/s
	加速度/accelerated speed	4g
数据更新率/data updating rate		Maximum 20Hz
导航数据格式/Navigation data format		RTCM2.3-3.3 NMEA 0183 Protocol Ver. 4.00/4.10, Cynosure GNSS Receiver Protocol

## 5 PIN 脚定义/ PIN Definition



图 5-1 SKG122ER 引脚定义/ Figure 5-1 SKG122ER pin definitions

表 5-1 引脚定义/ Table 5-1 Pin definitions

编号 /NO.	管脚名称/Pin Names	I/O	描述/Describe	备注/Remark
1	SPICX	O	SPICX, SPI 片选	
2	PRTRG	I/O	通用 IO/ General IO	
3	1PPS	O	秒脉冲输出/Second pulse output	不用则悬空/ If not use, dangling
4	EXTINT/SPEED	I	外在中断-/External interrupt -	外部中断信号（不用，则悬空） /External interrupt signal (If not use, dangling)
5	USBDN	I/O	USB_DN	
6	USBDP	I/O	USB_DP	
7	VUSB	I	USB 5V 供电电源	
8	RST	I	RESET, 内部有上拉	不用则悬空/ If not use, dangling
9	ANT_BIAS	O	天线供电电压输出（检测负载电流 2mA~20mA） / Antenna power supply voltage output (load current detection 2mA~20mA)	如需要天线开短路检测，则必须使用该引脚给有源天线供电 / This pin must be used to supply power to the active antenna if antenna short circuit detection is

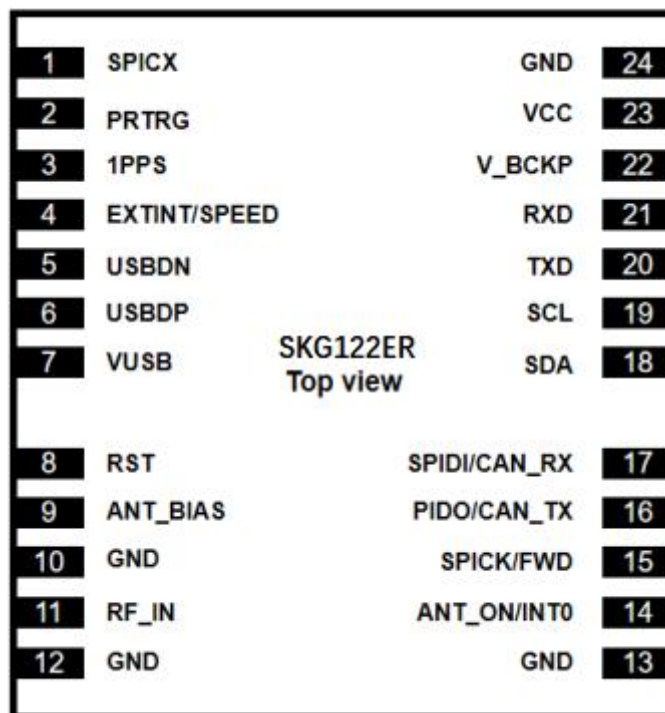

				required
10	GND	G	地/Ground	
11	RF_IN	I	天线输入/Antenna input	输入端需要做 50Ω阻抗匹配。 /50Ω impedance matching is required at the input
12	GND	G	地/Ground	
13	GND	G	地/Ground	
14	ANT_ON/INT0	I/O	ANT_EN, 有源天线电压控制输出;也可配置成输入中断/ ANT_EN, active antenna voltage control output; It can also be configured as input interrupt	
15	SPICK/FWD	O	SPI 时钟	
16	SPIDO/CAN_TX	O	SPI 输出, 或者 CAN 发射端/ SPI output, or CAN transmitter end	
17	SPIDI/CAN_RX	I	SPI 输入, 或者 CAN 接收端/ SPI input, or CAN receiver	
18	SDA	I/O	DDC 接口的数据信号/ Data signals of DDC interfaces	
19	SCL	I/O	DDC 接口的时钟信号/ Clock signal of the DDC interface	
20	TXD	O	串口发送 ( NMEA 数据输出、状态输出等) / Serial port transmission (NMEA data output, status output, etc.)	
21	RXD	I	串口接收(控制命令接收)/Serial port reception (control command reception)	
22	V_BCKP	I	备份电源/Backup power supply	2.0V~3.6V
23	VCC	I	主电源/main power supply	
24	GND	G	地/Ground	

## 6 电气特性/Electrical Characteristics

### 6.1 极限值/limit value

表 6-1 电源特性/Table 6-1 Features of the power supply

参数/Parameter	符号/Symbol	最小值/Min.	最大值/Max.	单位/Unit	条件/Condition
供电电压 (VCC)	VCC	-0.5	3.6	V	--
VCC 最大纹波/ VCC Maximum Ripple	Vrpp	0	50	mV	--
输入管脚电压/ Input pin voltage	Vin	-0.5	3.6	V	--
存储温度/ Storage Temperature	Tstg	-40	125	°C	--
ESD	VESD(HBM)	--	2000	V	All pins

### 6.2 运行条件/Operating Condition

表 6-2 运行条件/Table 6-2 Operating conditions

参数/Parameter	符号/Symbol	最小值/Min.	典型值/Type	最大值/Max.	单位/Unit
供电电压(VCC)	Vcc	3.0	3.3	3.6	V
RTC 供电电压(VRTC)	Vrtc	2.0	3.0	3.6	V
峰值电流/Peak Current	Iccp			47	mA
输入管脚低电平/Input pin low level	Vin_low	0		0.2*Vcc	V
输入管脚高电平/Input pin high level	Vin_high	0.67*Vcc		VCC	V
输出管脚低电平/Output pin low level	Vout_low			0.4	V
输出管脚高电平/Output pin high level	Vout_high	2.64			V
工作温度/operating temperature		-40		85	°C
存储温度/Storage Temperature		-40		125	°C

## 7 传输及外设接口/Transport And Peripheral Interface

### 7.1 PPS

秒脉冲 (PPS) : SKG122ER 提供非常精准的时间脉冲 PPS 信号, PPS 信号可为外部系统提供授时功能, 脉冲宽度可调, 精度 20nS, 默认情况下每秒输出一个脉冲。

Second pulse (PPS) : SKG122ER provides very precise time pulse PPS signal, PPS signal can provide timing function for external systems, pulse width adjustable, accuracy 20nS, output one pulse per second by default.

### 7.2 I2C (预留, 可定制) / I2C (Reserved, Customizable)

I2C 接口用于串行数据传输, 可以工作在 Master/Slave 模式。/The I2C interface is used for serial data transmission and can work in Master/Slave mode.

支持 7 位和 10 位寻址模式/ Support 7bit and 10bit addressing modes

支持 100K 的标准模式和 400K 的快速模式/ Supports 100K standard mode and 400K fast mode

支持 Msater 下的 DMA 数据移动/ Support DMA data movement under Msater

### 7.3 UART

支持数据传输、固件升级功能, 输入/输出信号类型为 LVTTTL 电平。默认波特率为 115200bps, 最高可设为 460800bps, 串口波特率均可由用户自行配置。

Supports data transmission and firmware upgrade. The input/output signal type is LVTTTL level. The default baud rate is 115200bps and the highest baud rate is 460800bps. The baud rate of the serial port can be set by users.

### 7.4 GPIO (预留, 可定制) / GPIO(Reserved, Customizable)

预留 1 个通用 GPIO 接口, 可由用户灵活配置。

One universal GPIO port is reserved for flexible configuration.

### 7.5 EXTINT (预留, 可定制) / EXTINT(Reserved, Customizable)

提供 1 个外部中断信号输入管脚。如果不使用, 该信号可以悬空。

Provides an external interrupt signal input pin. If not used, the signal can be suspended.

## 7.6 SPI（预留，可定制） / SPI(Reserved, Customizable)

预留 1 个 SPI 接口，可以工作在 Master/Slave 模式，支持公共 SPI 协议，同时也支持 I2C 音频协议（只支持输出）。

One SPI interface is reserved to work in Master/Slave mode and support the common SPI protocol and I2C audio protocol (only output).

## 7.7 USB（预留，可定制） / USB(Reserved, Customizable)

预留一个 USB 接口 2.0 FS 版本兼容接口(仅限设备)，可以作为通信的代替 UART 或其他通信接口。

Reserve a USB interface 2.0 FS compatible interface (only for devices), which can replace UART or other communication interfaces for communication.

支持 USB 2.0 速率最高为 12Mbps/ Support USB 2.0 speed up to 12Mbps

支持 windows XP/7/8/10, Android, Linux 操作系统/ Supports Windows XP/7/8/10, Android, and Linux operating systems

## 8 默认配置/ Default Configuration

消息类型/Message Type	参数名/parameter name	默认配置/Default Configuration	说明/Description
NMEA 消息/ NMEA messages	RMC	1	1Hz 输出/Output
	GGA	1	1Hz 输出/Output
	GSA	1	1Hz 输出/Output
	GSV	1	1Hz 输出/Output
	ZDA	1	1Hz 输出/Output
	GST	1	1Hz 输出/Output

SKG122ER 模块默认支持/ SKG122ER module supported by default:

GPS/QZSS :L1CA

GLONASS: L1

BeiDou: B1I

GALILEO: E1

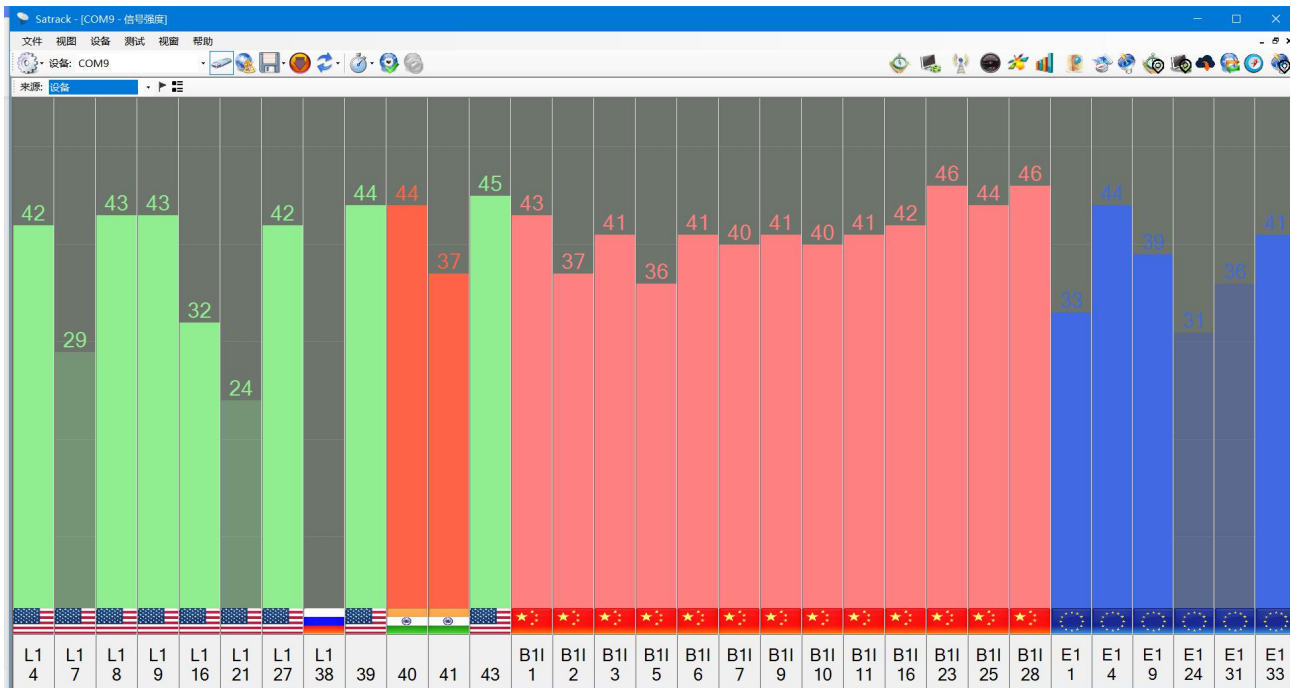

## 9 天线开短路检测/ Antenna Disconnection And Short-circuit Detection

SKG122ER 支持天线开短路检测，模块 ANT\_BIAS 天线负载电流范围 0~20mA。

SKG122ER supports antenna disconnection and short-circuit detection, and the module ANT\_BIAS antenna load current range of 0~20mA.

检测负载电流 0~2mA 时，检测状态为开路。

When the load current is 0 to 2mA, the detection state is disconnection.

检测负载电流 2~20mA 时，检测状态为正常。

When the load current is 2 ma to 20mA, the detection status is normal.

检测负载电流 45mA 以上时，检测状态为短路，会暂时关闭使用。

When the load current is detected above 45mA, the detection state is short-circuit, and the operation will be temporarily shut down.

## 10 软件说明/Software Specifications

### 10.1 NMEA 0183 协议/ NMEA 0183 Protocol

表 10.1-1 NMEA-0183 输出信息/ Nmea-0183 Output information

NMEA 协议	描述	默认
GGA	定位数据信息	打开
GSA	当前卫星信息	打开
GSV	可见卫星信息	打开
RMC	推荐定位信息	打开
ZDA	时间和日期信息	打开
GST	三维坐标标准偏差信息	打开

表 10.1-2 标识符助记码/ Table 10.1-2 Identifier mnemonics

标识符/Identifier	数据类型/Data type
BD	北斗模式/ Beidou Model
GP	GPS 模式/ GPS Model
GL	GLONASS 模式/ GLONASS Model
GA	GALILEO 模式/ GALILEO Model
GN	双模模式/ Dual-mode Model

## 10.2 GGA -定位数据信息/ GGA - Location Data Information

此语句包含定位位置、定位时间、定位精度。

This statement contains location, location time, and location accuracy.

\$GNGGA,033427.000,2238.3443413,N,11403.0966988,E,1,27,0.61,105.091,M,-2.200,M,,\*6A

表 10.2-1 GGA 语句格式/ Table 10.2-1 GGA statement formats

名称/Name	示例/Example	单位/Unit	描述/Description
语句 ID/Statement ID	\$GNGGA		表明语句为 GGA 信息
UTC 时间	033427.000		hhmmss.sss 时分秒格式
纬度/Latitude	2238.3443413		ddmm.mmmm 度分格式
纬度/Latitude	N/S		N=北纬 S=南纬/ N=Northern latitude S=South latitude
经度/Longitude	11403.0966988		dddmm.mmmm 度分格式
经度/Longitude	E/W		E=东经 W=西经/ E=East Longitude W=West Longitude
定位状态/ Positioning state	1		见附表 10.2-2/ See the table 10.2-2
已使用卫星数量/ Number of satellites in use	27		范围 0 到 24/ The range is from 0 to 24
HDOP 水平精度因子 /HDOP horizontal precision factor	0.61		
海拔高度/ Level	105.091	米/M	
大地水准面高度/Geoidal height	-2.200	米/M	
校验值/Proof test value	*6A		
EOL	<CR> <LF>		结束标志符/ End identifier

表 10.2-2 定位状态描述/ Table 10.2-2 Location status description

数值/Value	描述/Description
0	未定位或定位信息不可用/ No location or location information is unavailable
1	SPS 模式/ SPS model
2	GNSS, SPS 模式/ GNSS, SPS model
3	PPS 模式/ PPS model

### 10.3 GSA -当前卫星信息/ GSA - Current satellite information

此条语句包含模块的选定工作模式，定位类型，已使用卫星的 PRN 信息及 PDOP, HDOP, VDOP 等信息。

\$GNGSA,A,3,09,08,27,04,16,,,,,,,,,1.22,0.61,1.06,1\*07

\$GNGSA,A,3,04,33,09,31,01,,,,,,,,,1.22,0.61,1.06,3\*0C

\$GNGSA,A,3,25,43,39,23,28,40,16,01,06,03,09,07,1.22,0.61,1.06,4\*0D

\$GNGSA,A,3,10,11,02,41,05,,,,,,,,,1.22,0.61,1.06,4\*06

表 10.3-1 GSA 语句格式/ Table 10.3-1 GSA statement formats

名称/Name	示例/Example	单位/ Unit	描述/Description
语句 ID/ Statement ID	\$GPGSA		表明语句为 GSA 信息
模式 1/ Mode 1	A		表 10.3-3/ Table 10.3-3
模式 2/ Mode 2	3		表 10.3-2/ Table 10.3-2
已使用卫星 ID 信息/ ID information about the satellite in use	09		第一信道的 Sv 信息/Sv information of the first channel
已使用卫星 ID 信息/ ID information about the satellite in use	08		第二信道的 Sv 信息/Sv information of the second channel
...	...		...
已使用卫星 ID 信息/ ID information about the satellite in use	<Null>		十二信道的 Sv 信息（未使用则为空）/ Sv information for twelve channels (null if not in use)
PDOP	1.22		综合位置精度因子/ Synthesize position accuracy factor
HDOP	0.61		水平精度因子/ Horizontal accuracy factor
VDOP	1.06		垂直精度因子/ Vertical precision factor
校验值/Proof test value	1*07		
EOL	<CR> <LF>		结束标志符/ End identifier



表 10.3-2/ Table 10.3-2

值/Value	描述/Description
1	未定位/ Not locate
2	2D 定位/ 2D position
3	3D 定位/ 3D positioning

表 10.3-3/ Table 10.3-3

值/Value	描述/Description
M	手动选择 2D 或者 3D 模式/ Manually select 2D or 3D mode
A	自动选择 2D 或者 3D 模式/ Automatically select 2D or 3D mode

## 10.4 GSV -可见卫星信息/ GSV - Visible satellite information

此语句包含可见卫星的 PRNs, 方位角和仰角等信息。

This statement contains PRNs, azimuth and elevation of the visible satellite.

\$GPGSV,2,1,07,9,39,285,44,8,77,250,43,27,61,29,42,4,52,233,42,1\*6C

\$GPGSV,2,2,07,16,33,39,34,21,27,163,29,7,15,319,23,1\*59

\$GAGSV,2,1,07,4,42,218,44,33,43,127,40,9,33,288,39,31,43,328,38,7\*7F

\$GAGSV,2,2,07,1,37,43,34,24,,,31,12,17,181,,7\*78

\$BDGSV,5,1,18,25,35,86,46,43,60,65,45,39,57,174,45,23,56,12,45,1\*4D

\$BDGSV,5,2,18,28,50,187,45,40,59,343,43,16,69,182,42,1,46,123,42,1\*40

\$BDGSV,5,3,18,6,72,187,41,3,61,189,41,9,76,280,40,7,62,324,40,1\*77

\$BDGSV,5,4,18,10,56,298,40,11,35,46,40,2,46,235,37,41,10,199,37,1\*79

\$BDGSV,5,5,18,5,23,255,36,38,12,163,,1\*43

表 10.4-1 GSV 语句格式/ Table 10.4-1 GSV statement formats

名称/Name	示例/Example	单位/ Unit	描述/Description
语句 ID/ Statement ID	\$GPGSV		表明此语句为 GSV 信息/ Indicates that the statement is GSV information
GSV 总数信息/Indicates the total number of GSVs	2		本次 GSV 语句的总条数/ Total number of GSV statements
GSV 条数信息	1		本条语句为 GSV 语句中的第几条/ Order in GSV statements
可见卫星信息/ Visible satellite information	07		当前可见卫星总数/ Total number of currently visible satellites
卫星 ID/ Satellite ID	9		

卫星仰角/ Satellite elevation angle	39	度/Degrees	范围 00 到 90/ The range is 00 to 90
卫星方位角/ Satellite Azimuth	285	度/Degrees	范围 000 到 359/ The range is 000 to 359
信噪比(C/NO)	44	dB-Hz	范围 00 到 90 (未使用则为空) / Range 00 to 90 (null if not in use)
...			...
卫星 ID/ Satellite ID	4		
卫星仰角 Satellite elevation angle	52	度/Degrees	范围 00 到 90/ The range is 00 to 90
卫星方位角/ Satellite Azimuth	233	度/Degrees	范围 000 到 359/ The range is 000 to 359
信噪比(C/NO)	42	dB-Hz	范围 00 到 90 (未使用则为空) / Range 00 to 90 (null if not in use)
校验值/Proof test value	*6C		
EOL	<CR> <LF>		结束标志符/ End identifier

## 10.5 RMC -推荐定位信息/ RMC - Recommended Location Information

此语句包含推荐定位的卫星定位信息。

This statement contains satellite location information for the recommended location.

\$GNRMC,033427.000,A,2238.3443413,N,11403.0966988,E,0.002,149.90,280322,,A,S\*3A

表 10.5-1: RMC 语句格式/ Table 10.5-1: RMC statement formats

名称/Name	示例/Example	单位/ Unit	描述/Description
语句 ID/ Statement ID	\$GNRMC		表明此语句为 RMC 信息/ Indicates that the statement is RMC information
UTC 时间	033427.000		hhmmss.sss
使用状态/ User state	A/V		A=数据已使用 V=数据未使用/ A= Data in use V= Data not in use
纬度/Latitude	2238.3443413		ddmm.mmmm 度分格式
纬度/Latitude	N/S		N=北纬 S=南纬/ N=Northern latitude S=South latitude
经度/Longitude	11403.09467		dddmm.mmmm 度分格式
经度/Longitude	E/W		E=东经 W=西经/ E=East Longitude W=West Longitude
速度/Speed	0.002	节 /Paragraph	

方位角/Azimuth	149.90	度/Degrees	
UTC 日期	280322		ddmmyy
磁偏角/Declination	<Null>	度/Degrees	未使用则为空/Null if not in use
磁偏角方位/Magnetic declination azimuth	<Null>		E=东经 W=西经/ E=East Longitude W=West Longitude
定位模式/ Positioning Mode	A		A=自动, N=未定位, D=DGPS, E=DR/ A= automatic, N= unlocated, D=DGPS, E=DR
校验值/Proof test value	*3A		
EOL	<CR> <LF>		结束标志符/ End identifier

## 10.6 ZDA - 时间日期信息/ ZDA - Time and date information

此语句包含时间和日期信息

This statement contains the current time information.

\$GNZDA,033427.000,28,03,2022,00,00\*42

表 10.6-1: ZDA 语句格式/Table 10.6-1: ZDA statement formats

名称/Name	示例/Example	单位/ Unit	描述/Description
语句 ID/ Statement ID	\$GNZDA		表明此语句为 ZDA 信息/ Indicates that the statement is ZDA information
UTC 时间/ UTC time	033427.000		hhmmss (时分秒) 格式
UTC 日期/ UTC date	28		日/ day
UTC 日期/ UTC date	03		月/ Month
UTC 日期/ UTC date	2022		年/ Year
时区/ Timezone	00		
校验值/Proof test value	*42		结束标志符/ End identifier

## 10.7 GST - 三维坐标标准偏差信息/ GST - reports statistical information on the quality of the position solution

\$GNGST,033427.000,4.336,,4.194,4.197,4.348\*5C

表 10.7-1: GST 语句格式/Table 10.7-1: Formats of GST statements

名称/Name	示例/Example	单位/ Unit	描述/Description
语句 ID/ Statement ID	\$GNGST		表明此语句为 GST 信息 / Indicates that the statement is TXT information
UTC 时间/ UTC time	033427.000		hhmmss (时分秒) 格式
均方根偏差/RMS deviation	4.336		Total RMS standard deviation of ranges inputs to the navigation solution
...	...		...
纬度误差的偏差/Latitude error deviation	4.194		Standard deviation (meters) of latitude error
经度误差的偏差/Longitude error deviation	4.197		Standard deviation (meters) of longitude error
高度误差的偏差/Altitude error deviation	4.348		Standard deviation (meters) of latitude error
校验值/Proof test value	*5C		
EOL	<CR> <LF>		结束标志符/ End identifier

## 11 机械尺寸/Machine Dimension

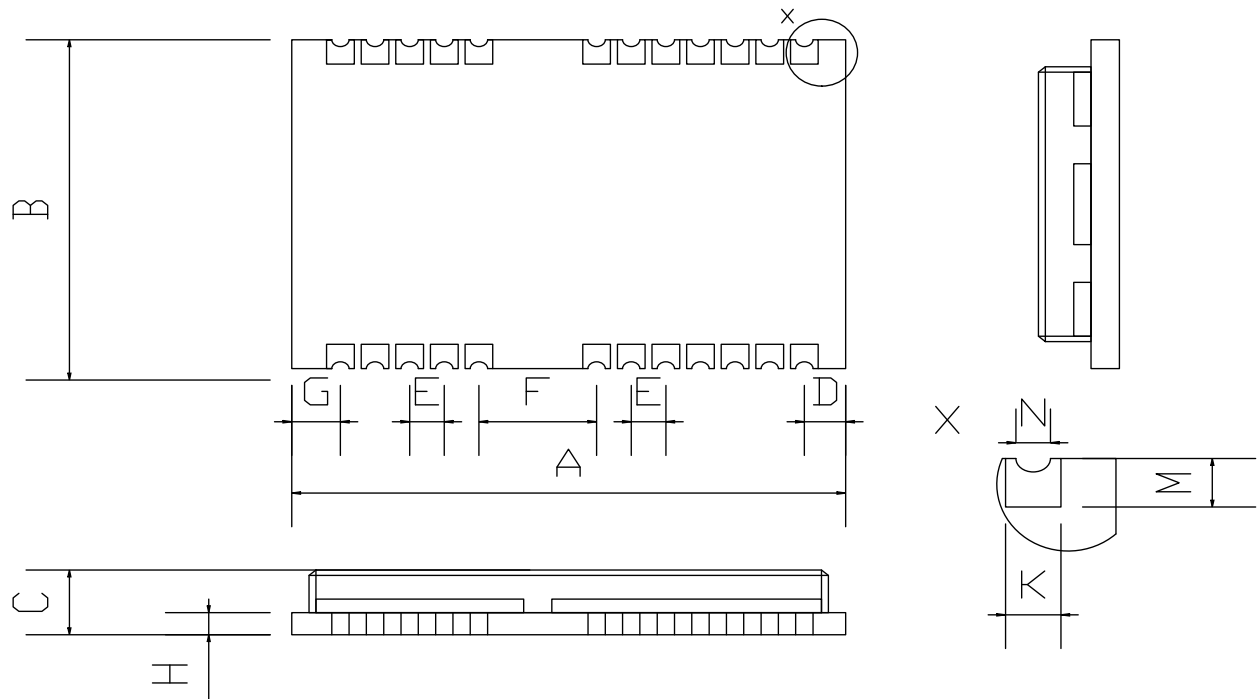

Parameter	specification	Units
Coplanarity	≤0.1	mm

Symbol	Min.(mm)	Type(mm)	Max.(mm)
A	16.0	16.3	16.6
B	12.0	12.2	12.4
C	2.2	2.4	2.6
D	0.9	1.0	1.3
E	1.0	1.1	1.2
F	2.9	3.0	3.1
G	0.9	1.0	1.3
H		0.8	
M	0.8	0.9	1.0
N	0.4	0.5	0.6
K	0.7	0.8	0.9
Weight	1.6g		

图 11-1 外形尺寸/Figure 11-1 External dimensions



图 11-2 参考封装尺寸/ Figure 11-2 Refer to package dimensions

## 11.1 Layout 注意事项

### 1) 元件布局/ Placing Components

GNSS 模块在 PCB 上的布局对于获得最佳的 GNSS 性能来说是至关重要的。与天线的连接应越短越好，避免对信号造成过大的衰减。在系统板设计上，要确保射频电路跟其他数字电路严格分开，将模块远离 PCB 上的数字区域。同时还必须将 GNSS 模块远离发热量较大的区域。

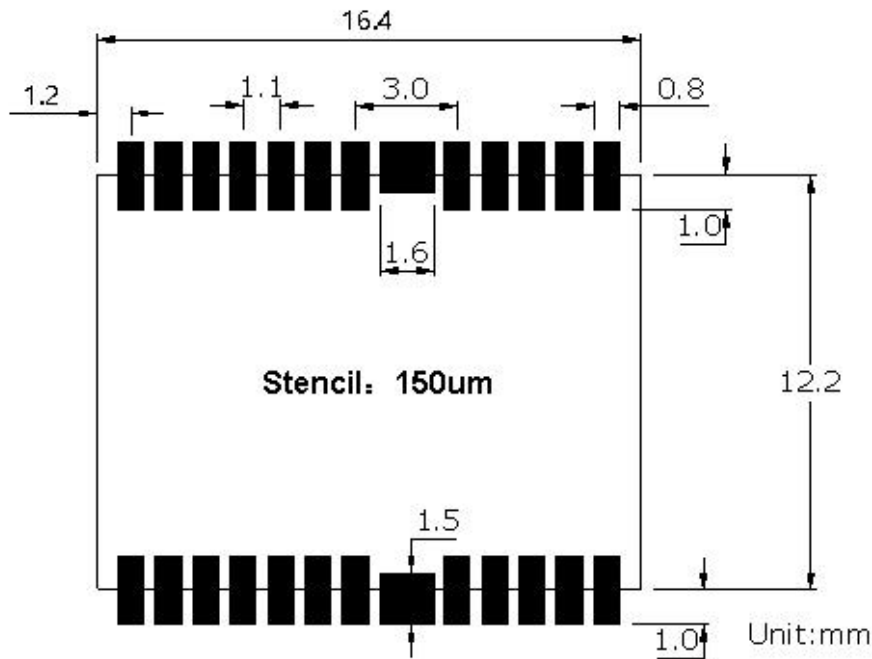
The layout of GNSS modules on the PCB is critical for achieving optimal GNSS performance. The connection with the antenna should be as short as possible to avoid excessive attenuation of the signal. In the system board design, ensure that RF circuits are strictly separated from other digital circuits and that modules are kept away from the digital area on the PCB. At the same time, GNSS modules must be kept away from areas with high heat.

### 2) 无源天线设计/ Passive Antenna Design

天线馈线的长度应尽可能短，且无源天线的下方要有一块完整的地。建议无源天线与 GNSS 模块放在 PCB 板相对的另一面。

The length of the antenna feeder should be as short as possible, and the passive antenna should have a complete ground below. It is recommended that the passive antenna and GNSS module be placed on the opposite side of the PCB board.



图 11.1-1 SKG122ER 参考设计/ Figure 11.1-1 SKG122ER reference design

### 3) 阻抗匹配/ Impedance Matching

天线馈线的阻抗需为 50 Ohm，为了达到 50 Ohm 的阻抗，微带线的宽度  $W$  要根据导线和参考面的距离  $H$ ，PCB 介质板的介电常数  $\epsilon_r$ ，以及 PCB 的结构来选择。

The impedance of the antenna feeder shall be 50 Ohm. In order to achieve the impedance of 50 Ohm, the width  $W$  of the microstrip line shall be selected according to the distance  $H$  between the wire and the reference plane, the dielectric constant  $\epsilon_r$  of the PCB dielectric board, and the structure of the PCB.

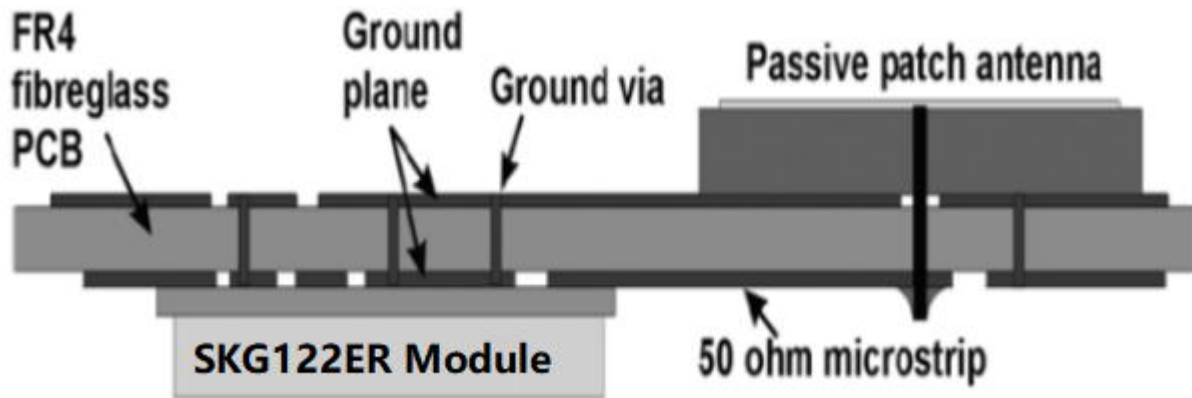
### 4) 微带线设计/ Microstrip line design

微带线的长度应该尽可能的短，标准 PCB 上应该尽量不选用超过 2.5 cm (1 inch) 而又没有屏蔽层的微带线；

The length of microstrip lines should be as short as possible, and no microstrip lines exceeding 2.5cm (1 inch) without shielding layer should be selected on standard PCB as far as possible.

射频连接线的走线应避免靠近数字信号线；

Avoid routing RF cables close to digital signal cables.在连接地平面时要采用尽可能多的过孔；

在连接地平面时要采用尽可能多的过孔；

Wiring should be far away from noise sources, such as switching power supply, digital signal, crystal oscillator, processor, etc.

布线应远离噪声源，如：开关电源，数字信号，晶振，处理器等；

Wiring should be far away from noise sources, such as switching power supply, digital signal, crystal oscillator, processor, etc.

微带线相对应的参考地层应保持完整；

The reference strata corresponding to the microstrip line should be kept intact.

微带线特性阻抗必须为 50 ohm;

The characteristic impedance of microstrip line must be 50 ohm;

为了减小信号衰减，微带线走线时要避免锐角。

In order to reduce signal attenuation, the acute Angle should be avoided when microstrip lines are routed.



图 11.1-2 SKG122ER 微带线设计推荐/ Figure 11.1-2 SKG122ER microstrip cable design

## 12 包装规格

模块采用卷带包装，每卷 1200 片。

The module is packaged in rolls with 1200 pieces per roll.

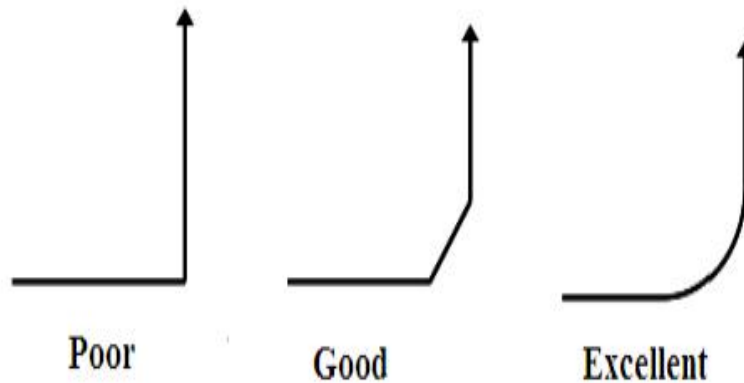

图 12-1 SKG122ER 包装图/ Figure 12-1 Packing diagram of the SKG122ER



### 13 贴片建议

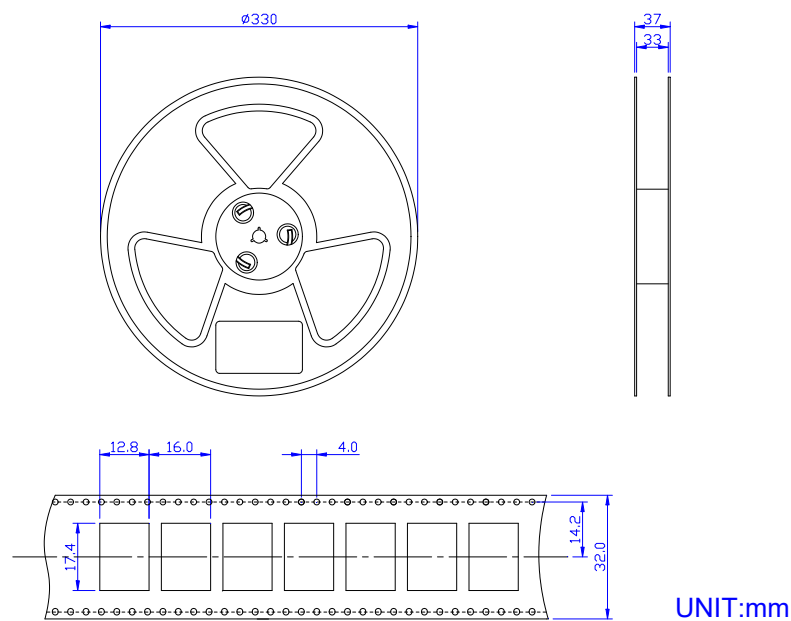

图 13-1 SKG122ER 推荐炉温曲线/ Figure 13-1 SKG122ER recommended furnace temperature curve

**Melting Temperature: 217 °C**

**Stencil Thickness: 150um**

## 14 参考电路

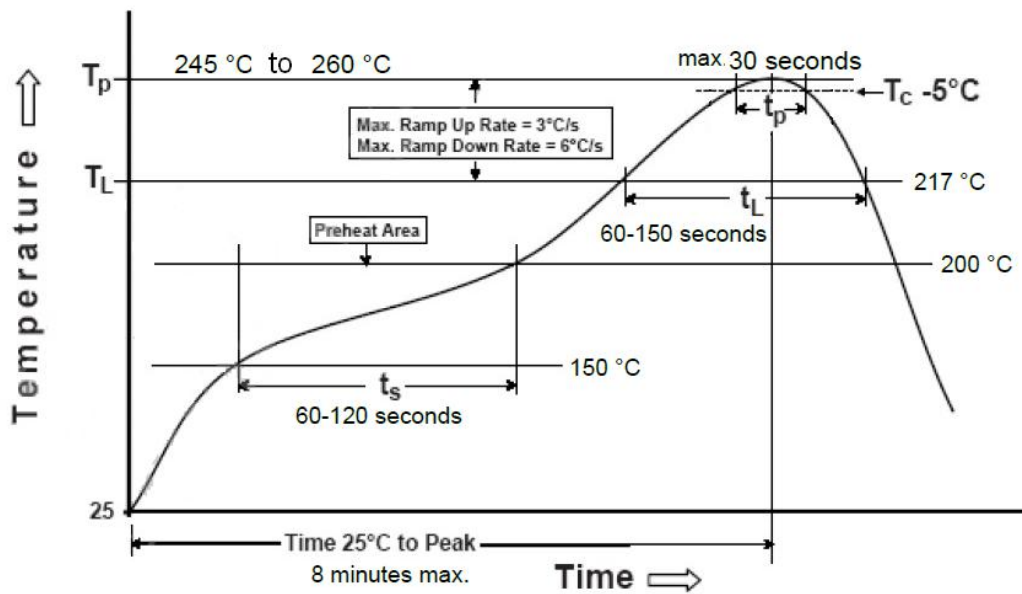
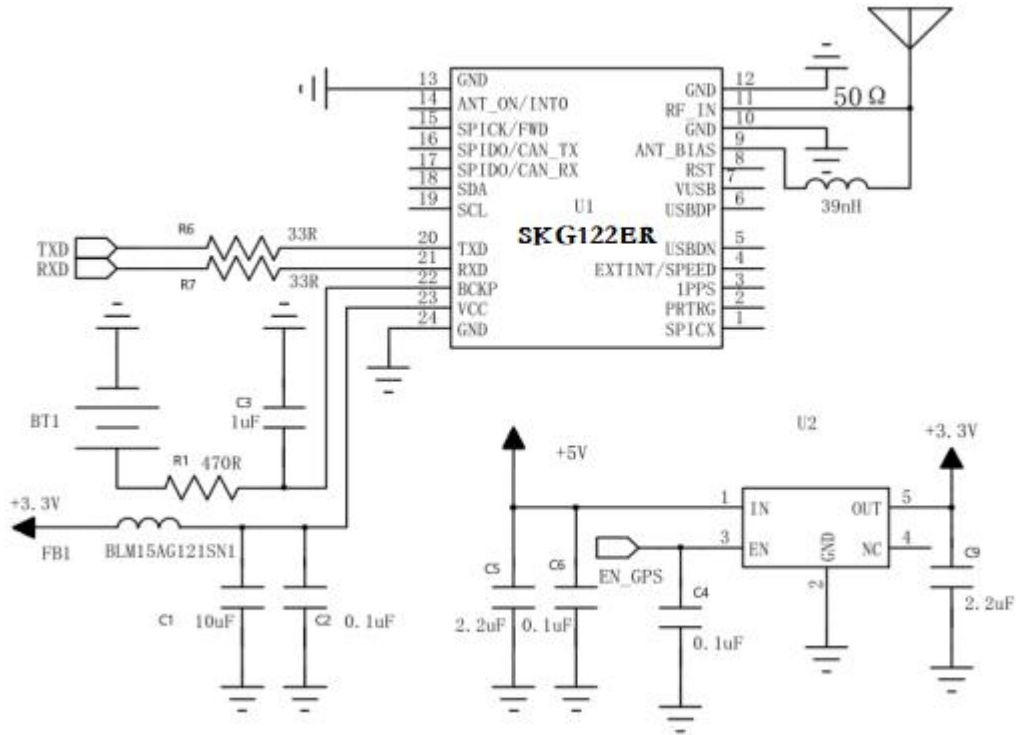

SKG122ER 参考电路/ SKG122ERReference Circuit

## 15 联系方式/ Contact Information

**Skylab M&C Technology Co., Ltd.**

深圳市天工测控技术有限公司

地址: 深圳市龙华区龙华街道工业东路利金城科技工业园 9# 厂房 6 楼

电话: 86-755 8340 8210 (Sales Support)

电话: 86-755 8340 8510 (Technical Support)

传真: 86-755-8340 8560

邮箱: [technicalsupport@skylab.com.cn](mailto:technicalsupport@skylab.com.cn)

网站: [www.skylab.com.cn](http://www.skylab.com.cn)     [www.skylabmodule.com](http://www.skylabmodule.com)