

LS-TM8N Datasheet

GPS/GLONASS/BDS

Module

Document Information		
Title	LS-TM8N High-performance GPS/GLONASS/DB Solution Module Datasheet	
Document type	Datasheet	
Revision and date	V2.01	29-Apr.-2021
Disclosure restriction	Public	

Revision History

Revision	Description	Approved	Date
V1.01	Initial Release	George He	20170508
V1.02	Update certification information	George He	20170831
V1.03	Update Order Information	George He	20171018
V2.01	Update format	Wendy	20210429

SKYLAB reserves all rights to this document and the information contained herein. Products, names, logos and designs described herein may in whole or in part be subject to intellectual property rights. Reproduction, use, modification or disclosure to third parties of this document or any part thereof without the express permission of SKYLAB is strictly prohibited.

The information contained herein is provided “as is” and SKYLAB assumes no liability for the use of the information. No warranty, either express or implied, is given, including but not limited, with respect to the accuracy, correctness, reliability and fitness for a particular purpose of the information. This document may be revised by SKYLAB at any time. For most recent documents, visit www.skylab.com.cn.

Copyright © 2017, Skylab M&C Technology Co., Ltd.

SKYLAB® is a registered trademark of Skylab M&C Technology Co., Ltd in China.

Contents

1. General Description.....	5
2. Applications.....	5
3. Features.....	5
4. Pin Assignment.....	6
5. Pin Description.....	7
6. Interfaces.....	8
Power Supply.....	8
UART.....	8
7. Advanced Software Features.....	8
Assisted GNSS.....	8
GNSS.....	8
8. Performance Specification.....	9
9. Electrical Characteristics.....	9
Absolute Maximum Rating.....	9
Operating Conditions.....	10
10 .Mechanical Specification.....	10
11.Recommend Layout.....	11
12.Order Information.....	11
13.Reference design schematic.....	12
14.Packaging Specification.....	13
15.Manufacturing Process Recommendations.....	14
16.Software Protocol.....	15
NMEA 0183 Protocol.....	15
GGA-Global Positioning System Fixed Data.....	15
GLL-Geographic Position – Latitude/Longitude.....	17

GSA-GNSS DOP and Active Satellites.....	17
GSV-GNSS Satellites in View.....	19
RMC-Recommended Minimum Specific GNSS Data.....	20
VTG-Course Over Ground and Ground Speed.....	20
ZDA-Date and Time.....	21
17.Contact Information.....	22

1. General Description

The LS-TM8N is a high-performance GNSS all-in-one solution module that features super sensitivity, ultra low power and small form factor. The RF signal is applied to the antenna input of module, and a complete serial data message with position, velocity and time information is presented at the serial interface with UBX protocol or NMEA protocol. It is based on the high performance features single-chip architecture, Its -162dBm tracking sensitivity extends positioning coverage into place like urban canyons and dense foliage environment where the GNSS was not possible before. It Built-in low-field magnetic sensor



Figure 1: LS-TM8N Top View

2. Applications

- ◆ LBS (Location Based Service)
- ◆ PND (Portable Navigation Device)
- ◆ Vehicle navigation system
- ◆ Aeromodelling

3. Features

- ◆ GPS/GLONASS/BDS/GALILEO/QZSS receiver
- ◆ Ultra high sensitivity: -162dBm

- ◆ Extremely fast TTFB at low signal level
- ◆ ± 10 ns high accuracy time pulse (1PPS)
- ◆ Assisted GNSS
- ◆ SBAS (WAAS,EGNOS,GAGAN,MSAS)
- ◆ Support A-GPS
- ◆ RoHS compliance (Lead-free)
- ◆ FCC,CE compliance

4. Pin Assignment

1	FIXLED	GND	24
2	GPIO7	VCC	23
3	PPS	V_BCKP	22
4	GPIO8	RXD0	21
5	NC	TXD0	20
6	NC	RXD1	19
7	NC	TXD1	18
8	V_ANT	NC	17
9	V_ANT_OUT	NC	16
10	GND	GPIO3	15
11	RF_IN	GPIO2	14
12	GND	GND	13

LS-TM8N
Top view

Figure 2: LS-TM8N Pin Assignment

5. Pin Description

Pin No.	Pin name	I/O	Description	Remark
1	FIXLED	O	Fixed LED Output	Default off .Leave open if not used
2	GPIO7	I/O	General Purpose I/O	Leave open if not used
3	PPS	O	Time Pulse Signal (Default 100ms)	Leave open if not used
4	GPIO8	I/O	General Purpose I/O	Leave open if not used
5	NC			
6	NC			
7	NC			
8	V_ANT	I	Active Antenna External Voltage Supply	Leave open if not used
9	V_ANT_OUT	O	Voltage Output for External Active Antenna	Leave open if not used
10	GND	G	Ground	
11	RF_IN	I	RF Signal Input	50Ω
12	GND	G	Ground	
13	GND	G	Ground	
14	GPIO2	I/O	General Purpose I/O	Leave open if not used
15	GPIO3	I/O	General Purpose I/O	Leave open if not used
16	NC			
17	NC			
18	TXD1	O	UART Serial Data Output 1	GPIO4
19	RXD1	I	UART Serial Data Input 1	GPIO5
20	TXD0	O	UART Serial Data Output 0	GPIO0
21	RXD0	I	UART Serial Data Input 0	GPIO1
22	V_BCKP	I	RTC and backup SRAM power	This pin may be connect to Battery or Power Supply(1.5~3.6V)
23	VCC	P	Module Power Supply	Operating range: 3.3±10%, 100mA V
24	GND	G	Ground	

6. Interfaces

Power Supply

Regulated power for the LS-TM8N is required. The input voltage VCC should be 3.0V to 3.6V range, current is no less than 100mA. Suitable decoupling must be provided by external decoupling circuitry (10uF and 1uF). It can reduce the Noise from power supply and increase power stability.

Main power supply VCC current varies according to the processor load and satellite acquisition. Average supply current is about 100 mA during acquisition.

UART

The module supports one full duplex serial channels UART. The serial connections are at 3.3V LVTTTL logic levels, if need different voltage levels, use appropriate level shifters. the data format is however fixed: X, N, 8, 1, i.e. X baud rate, no parity, eight data bits and one stop bit, no other data formats are supported, LSB is sent first.

7. Advanced Software Features

Assisted GNSS

Supply of aiding information, such as ephemeris, almanac, rough last position and time, will reduce the time to first fix significantly and improve the acquisition sensitivity.

GNSS

The LS-TM8N GNSS modules can receive and track multiple GNSS systems (e.g. GPS, GLONASS, GALILEO and BDS signals). The LS-TM8N can be configure to start searching of which satellite system. By default the receivers are configured for concurrent GPS and BDS reception.

8. Performance Specification

Parameter	Specification	
Receiver Type	GPS, GLONASS, BD	
Sensitivity	Tracking	-162dBm Typical
	Acquisition	-148dBm Typical
Accuracy	Position	3.0m CEP50 without SA
	Velocity	0.1m/s
Time To First Fix	Cold Start	32s(Typical Open Sky)
	Hot Start	1s
Power Consumption	Tracking	28mA @3.3V Typical
	Acquisition	30mA @3.3V
Navigation Data Update Rate	Max 10Hz	Default 1Hz
Operational Limits	Altitude	Max 18,000m
	Velocity	Max 500m/s
	Acceleration	Less than 4g

9. Electrical Characteristics

Absolute Maximum Rating

Parameter	Symbol	Min	Max	Units
Power Supply				
Power Supply Volt.	VCC	-0.3	3.6	V
Input Pins				
Input voltage on any input connection	VIO	-0.3	VCC+0.2	V
RF input power	RF_IN		0	dBm
Human Body Model ESD capability	RF_IN		2000	V
Machine Model ESD capability	RF_IN		100	V
Environment				
Storage Temperature	Tstg	-40	85	°C
Peak Reflow Soldering Temperature <10s	Tpeak		260	°C
Humidity			95	%

Note: Absolute maximum ratings are stress ratings only, and functional operation at the maxims is not guaranteed. Stress beyond the limits specified in this table may affect device reliability or cause permanent damage to the device. For functional operating conditions, refer to the operating conditions tables as follow.

The LS-TM8N module is Electrostatic Sensitive Device (ESD) and may be damaged with ESD or spike voltage. Although it has built-in ESD protection circuitry, please handle with care to avoid permanent malfunction or performance degradation.

Operating Conditions

Parameter	Symbol	Condition	Min	Typ	Max	Units
Power supply voltage	Vcc		3	3.3	3.6	V
Backup Battery	V_BCKP		1.5	3.0	3.6	V
Power supply voltage ripple	Vcc_PP	Vcc=3.3V			30	mV
Supply current, Acquisition	Icc	Vcc=3.3V		30		mA
Supply current, Tracking	Icc	Vcc=3.3V		28		mA
VCC peak current	Ipeak				100	mA
V_BCKP current	IRTC			12		uA
V_ANT_OUT supply voltage	VANT			3.3		V
V_ANT_OUT current	IANT				50	mA
Operating temperature	Topr		-40		85	°C

10.Mechanical Specification

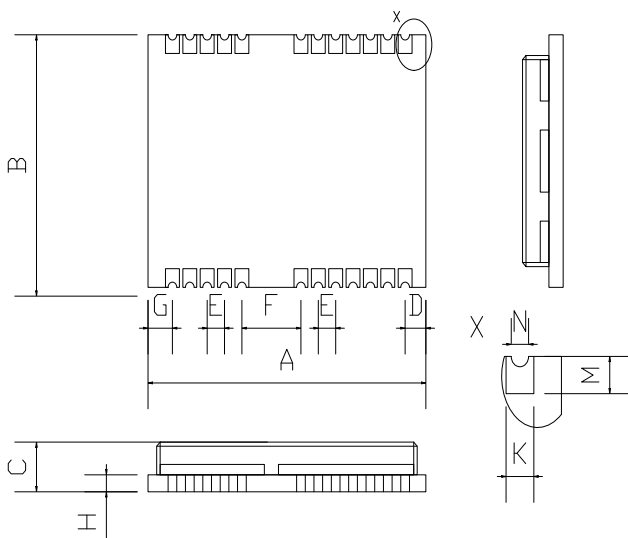

Symbol	Min.(mm)	Typ.(mm)	Max.(mm)
A	16.0	16.3	16.6
B	12.0	12.2	12.4
C	2.2	2.4	2.6
D	0.9	1.0	1.3
E	1.0	1.1	1.2
F	2.9	3.0	3.1
G	0.9	1.0	1.3
H		0.8	
M	0.8	0.9	1.0
N	0.4	0.5	0.6
K	0.7	0.8	0.9
Weight		1.6g	

Parameter	specification	Units
Coplanarity	≤0.1	mm

Figure 3: LS-TM8N Dimensions

11.Recommend Layout

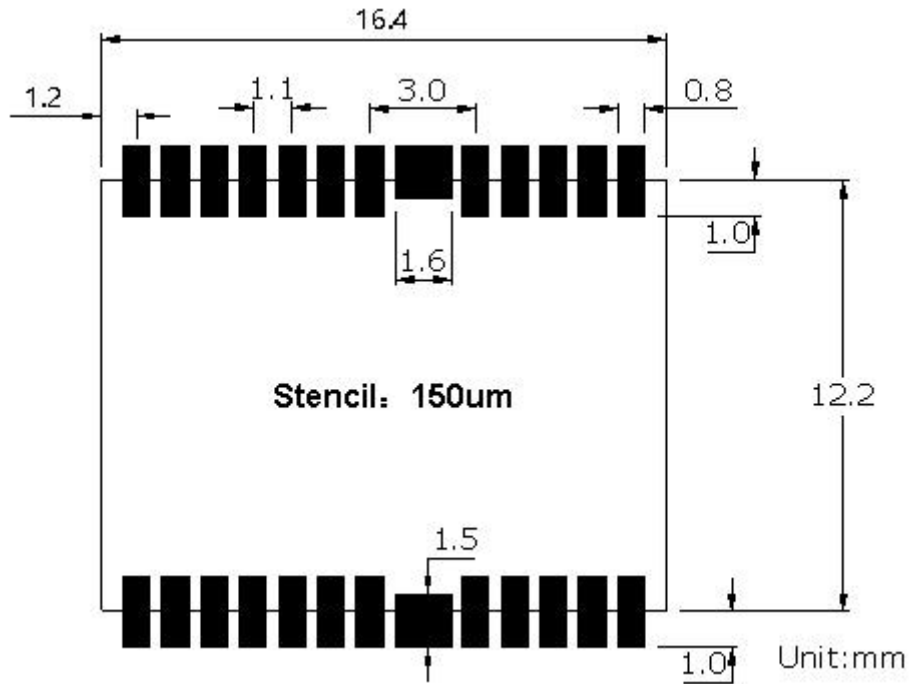

Figure 4: LS-TM8N Recommend Layout

12.Order Information

Part No.	Mode			Power	Interface		Feature					
	GPS	BDS	GLONASS		UART1	UART2	Flash	TCXO	Antenna Check	ANT Protection	SAW	LNA
LS-TM8N-1X	●			2.7V-3.6V	●	●	●	●	●	●	●	●
LS-TM8N-3X	●	●		●	●	●	●	●	●	●	●	●
LS-TM8N-5X	●		●	●	●	●	●	●	●	●	●	●
LS-TM8N-7X	●	●	●	●	●	●	●	●	●	●	●	●

13.Reference design schematic

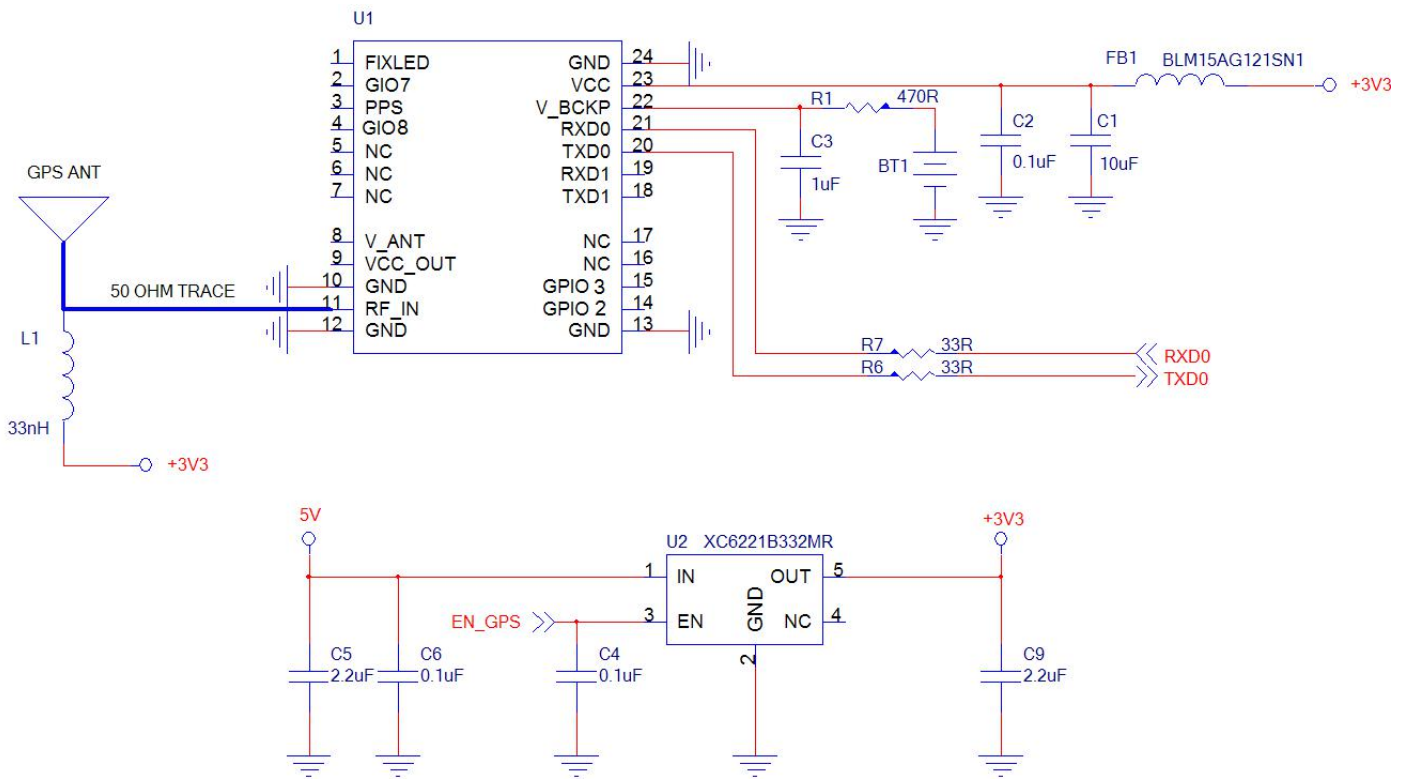

Figure 5: LS-TM8N Typical Reference design schematic

14. Packaging Specification

LS-TM8N modules are shipped in reel and with 1200 units per reel. Each tray is 'dry' package.

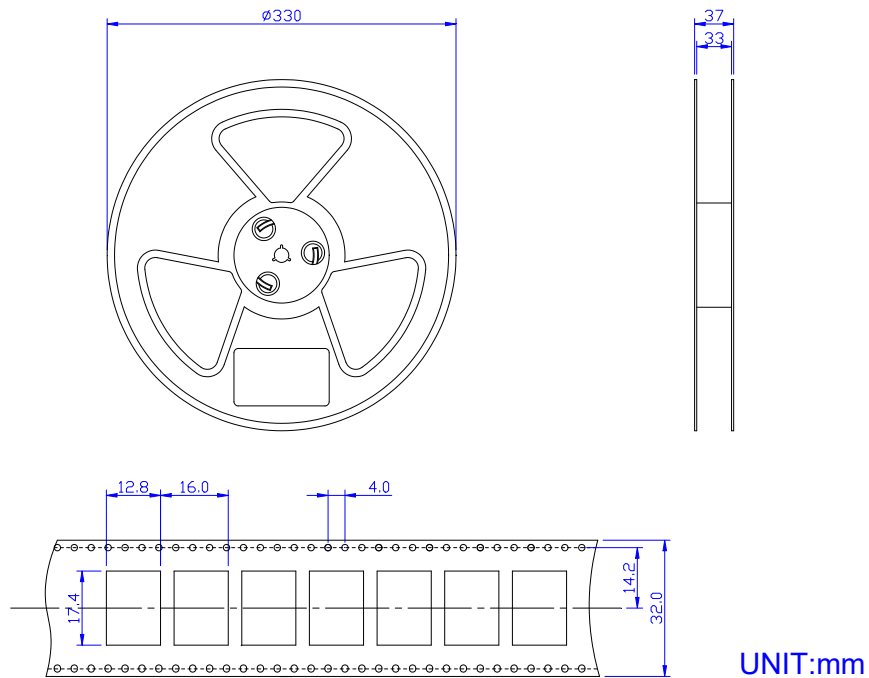

Figure 6: LS-TM8N Packaging

15.Manufacturing Process Recommendations

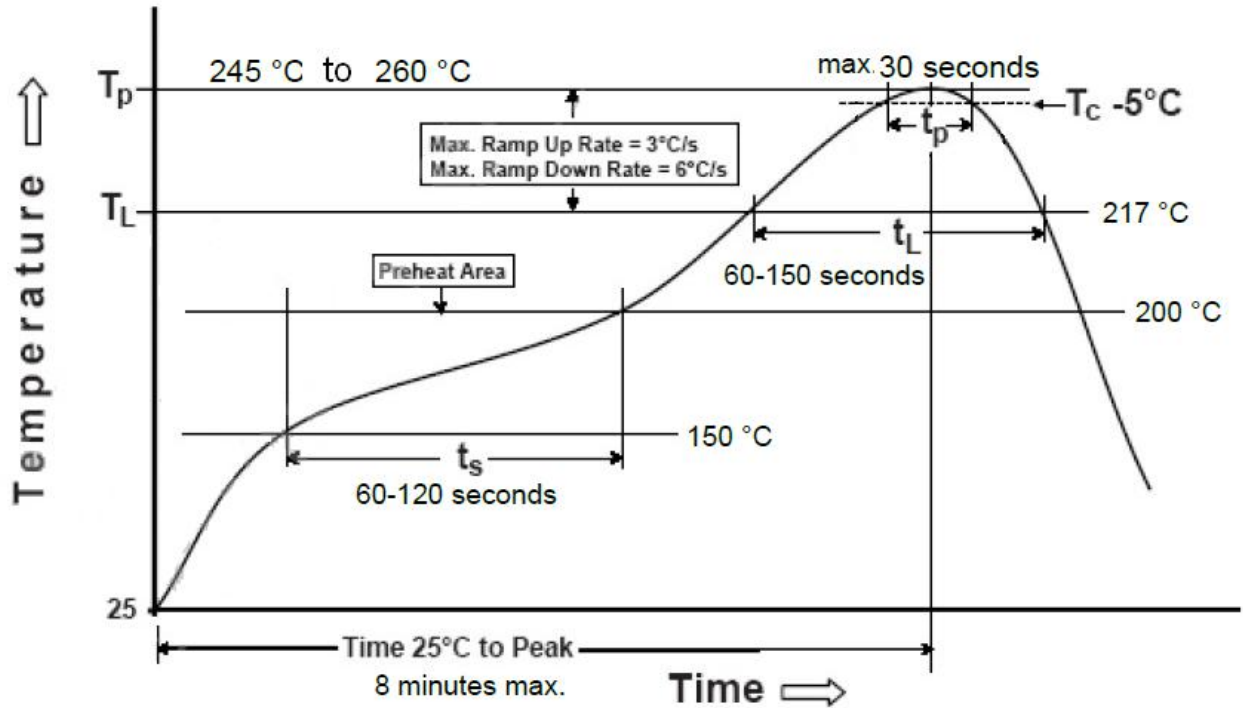

Figure 7: LS-TM8N Typical Leadfree Soldering Profile

Note: The final soldering temperature chosen at the factory depends on additional external factors like choice of soldering paste, size, thickness and properties of the baseboard, etc. Exceeding the maximum soldering temperature in the recommended soldering profile may permanently damage the module.

16. Software Protocol

NMEA 0183 Protocol

The NMEA protocol is an ASCII-based protocol, Records start with a \$ and with carriage return/line feed. GPS specific messages all start with \$GNxxx where xxx is a three-letter identifier of the message data that follows. NMEA messages have a checksum, which allows detection of corrupted data transfers. The Skylab LS-TM8N supports the following NMEA-0183 messages: GGA, GLL, GSA, GSV, RMC VTG, ZDA. The module default NMEA-0183 output is set up GGA、GSA、RMC、GSV , and default baud rate is set up 9600bps

Table 1: NMEA-0183 Output Messages

NMEA Record	Description	Default
GNGGA	Global positioning system fixed data	Y
GNLL	Geographic position—latitude/longitude	N
GPGSA	GNSS DOP and active satellites for GPS	Y
GLGSA	GNSS DOP and active satellites for GLONASS	N
BDGSA	Beidou DOP and active satellites for BD	Y
GPGSV	GNSS satellites in view for GPS	Y
GLGSV	GNSS satellites in view for GLONASS	N
BDGSV	Beidou satellites in view for BD	Y
GNRMC	Recommended minimum specific GNSS data	Y
GNVTG	Course over ground and ground speed	N
GNZDA	Date and Time	N

GGA-Global Positioning System Fixed Data

This sentence contains the position, time and quality of the navigation fix.

See RMC for Fix Status, Fix Mode, Fix Date, Speed, and True Course.

See GSA for Fix Type, PDOP, and VDOP.

\$GNGGA,021514.000,2232.1799,N,11401.1823,E,1,6,1.25,84.0,M,-2.2,M,,*6A

Table 2: GGA Data Format

Name	Example	Units	Description
Message ID	\$GNGGA		GGA protocol header
UTC Position	021514.000		hhmmss.sss
Latitude	2232.1799		ddmm.mmmm
N/S indicator	N		N=north or S=south
Longitude	11401.1823		dddmm.mmmm
E/W Indicator	E		E=east or W=west
Position Fix Indicator	1		See Table 2-1
Satellites Used	6		Range 0 to 12
HDOP	1.25		Horizontal Dilution of Precision
MSL Altitude	84.0	meters	Altitude (referenced to the Ellipsoid)
AltUnit	M	meters	Altitude Unit
GeoSep	-2.2	meters	Geoidal Separation
GeoSepUnit	M	meters	Geoidal Separation Unit
Age of Diff.Corr.	<Null>	second	Null fields when it is not Used
Diff.Ref.Station ID	<Null>		Null fields when it is not Used
Checksum	*6A		
EOL	<CR> <LF>		End of message termination

Table 2-1: Position Fix Indicators

Value	Description
0	Fix not available or invalid
1	fix valid
2	Differential GPS, fix valid

GLL-Geographic Position – Latitude/Longitude

This sentence contains the fix latitude and longitude.

\$GNGLL,2232.1799,N,11401.1824,E,021513.000,A,A*4E

Table 3: GLL Data Format

Name	Example	Units	Description
Message ID	\$GNGLL		GLL protocol header
Latitude	2232.1799		ddmm.mmmm
N/S Indicator	N		N=north or S=south
Longitude	11401.1824		dddmm.mmmm
E/W Indicator	E		E=east or W=west
UTC Position	021513.000		hhmmss.sss
Fix Status	A		A=data valid or V=data not valid
Fix Mode	A		A=autonomous, N = No fix, D=DGPS, E=DR
Checksum	*4E		
EOL	<CR> <LF>		End of message termination

GSA-GNSS DOP and Active Satellites

This sentence contains the mode of operation, type of fix, PRNs of the satellites used in the solution as well as PDOP, HDOP and VDOP.

GPS GSA message: \$GPGSA,.....

\$GPGSA,A,3,28,20,04,17,10,193,08,,,,,1.14,0.75,0.85*31

GLONASS GSA message: \$GLGSA,.....

\$GLGSA,A,3,67,81,80,66,82,79,,,,,1.14,0.75,0.85*11

BD GSA message: \$BDGSA,.....

\$BDGSA,A,3,10,,,,,,,,,1.54,1.26,0.88*17

Table 4: GSA Data Format

Name	Example	Units	Description
Message	\$GPGSA		GSA protocol header
Mode 1	A		See Table 4-2
Mode 2	3		See Table 4-1
ID of satellite used	28		Sv on Channel 1
ID of satellite used	20		Sv on Channel 2
...
ID of satellite used	<Null>		Sv on Channel 12 (Null fields when it is not Used)
PDOP	1.14		Position Dilution of Precision
HDOP	0.75		Horizontal Dilution of Precision
VDOP	0.85		Vertical Dilution of Precision
Checksum	*31		
EOL	<CR> <LF>		End of message termination

Table 4-1: Mode 2

Value	Description
1	Fix not available
2	2D Fix
3	3D Fix

Table 4-2: Mode 1

Value	Description
M	Manual-forced to operate in 2D or 3D mode
A	Automatic-allowed to automatically switch 2D/3D

GSV-GNSS Satellites in View

This sentence contains the PRNs, azimuth, elevation, and signal strength of all satellites in view.

GPS GSV message: \$GPGSV,.....

\$GPGSV,4,1,14,28,86,009,35,193,70,056,38,04,44,258,29,17,44,338,44*48

GLONASS GSV message: \$GLGSV,.....

\$GLGSV,3,1,10,79,42,239,15,66,40,076,31,67,37,143,29,81,33,025,14*66

BD GSV message: \$BDGSV,.....

\$BDGSV,1,1,03,10,46,329,31,08,43,161,,09,40,217,*52

Table 5: GSV Data Format

Name	Example	Units	Description
Message ID	\$GPGSV		GSV protocol header
Number of Message	4		Total number of GSV sentences (Range 1 to 3)
Message Number	1		Sentence number of the total (Range 1 to 3)
Satellites in View	14		Number of satellites in view
Satellite ID	28		Channel 1
Elevation	86	degrees	Channel 1(Range 00 to 90)
Azinmuth	009	degrees	Channel 1(Range 000 to 359)
SNR(C/NO)	35	dB-Hz	Channel 1(Range 00 to 99, null when not tracking)
...			...
Satellite ID	17		Channel 4
Elevation	44	degrees	Channel 4(Range 00 to 90)
Azimuth	338	degrees	Channel 4(Range 000 to 359)
SNR(C/NO)	44	dB-Hz	Channel 4(Range 00 to 99, null when not tracking)
Checksum	*48		
EOL	<CR> <LF>		End of message termination

Depending on the number of satellites tracked multiple messages of GSV data may be required.

RMC-Recommended Minimum Specific GNSS Data

This sentence contains the recommended minimum fix information.

See GGA for Fix Quality, Sats Used, HDOP, Altitude, Geoidal Separation, and DGPS data.

See GSA for Fix Type, PDOP and VDOP.

\$GNRMC,023345.000,A,2232.1767,N,11401.1953,E,0.18,151.55,100410,,,A*76

Table 6: RMC Data Format

Name	Example	Units	Description
Message ID	\$GNRMC		RMC protocol header
UTS Position	023345.000		hhmmss.sss
Status	A		A=data valid or V=data not valid
Latitude	2232.1767		ddmm.mmmm
N/S Indicator	N		N=north or S=south
Longitude	11401.1953		dddmm.mmmm
E/W Indicator	E		E=east or W=west
Speed Over Ground	0.18	Knots	
Course Over Ground	151.55	Degrees	True Course
Date(UTC)	100410		ddmmyy
Magnetic variation	<Null>	Degrees	Null fields when it is not Used
Magnetic Variation Direction	<Null>		E=east or W=west (Null fields when it is not Used)
Fix Mode	A		A=autonomous, N = No fix, D=DGPS, E=DR
Checksum	*76		
EOL	<CR> <LF>		End of message termination

VTG-Course Over Ground and Ground Speed

This sentence contains the course and speed of the navigation solution.

\$GNVTG,148.81,T,,M,0.13,N,0.24,K,A*23

Table 7: VTG Data Format

Name	Example	Units	Description
Message ID	\$GPVTG		VTG protocol header
Tcourse	148.81	Degrees	True Course
Reference	T		T = True
Mcourse	<Null>	Degrees	Magnetic Course (Null fields when it is not Used)
Reference	M		M = Magnetic (Null fields when it is not Used)
Speed over ground	0.13	Knots	Nautical Miles per Hour
Units	N		Knots
Speed over ground	0.24	Km/hr	in Kilometers per Hour
Units	K		Kilometer per hour
Mode	A		A=Autonomous, N=No fix, D=DGPS, E=DR
Checksum	*23		
EOL	<CR> <LF>		End of message termination

ZDA-Date and Time

This sentence contains UTC date & time, and local time zone offset information.

\$GNZDA,023345.000,10,04,2010,.,*4D

Table 8: ZDA Data Format

Name	Example	Units	Description
Message ID	\$GPZDA		ZDA protocol header
UTC Time	023345.000		hhmmss.sss
Day	10		UTC time: day (01 ... 31) dd
Month	04		UTC time: month (01 ... 12) mm
Year	2010		UTC time: year (4 digit year) yyyy
local zone hours	<null>		Local Time Zone Offset Hours (Null fields when it is not Used)

local zone minutes	<null>		Local Time Zone Offset Minutes (Null fields when it is not Used)
Checksum	*4D		
EOL	<CR> <LF>		End of message termination

17. Contact Information

Skylab M&C Technology Co., Ltd.

深圳市天工测控技术有限公司

Address: 6 Floor, No.9 Building, Lijincheng Scientific & Technical park, Gongye East Road,
Longhua District, Shenzhen, Guangdong, China

Phone: 86-755 8340 8210 (Sales Support)

Phone: 86-755 8340 8510 (Technical Support)

Fax: 86-755-8340 8560

E-Mail: sales1@skylab.com.cn

Website: www.skylab.com.cn www.skylabmodule.com