

# WG233 Datasheet

## 802.11 a/b/g/n/ac 2T2R

### USB WiFi Module

---

<b>Title</b>	WG233 Datasheet 802.11 a/b/g/n/ac 2T2R USB WiFi Module	
<b>Document type</b>	Datasheet	
<b>Document number</b>	SL-19050128	
<b>Revision and date</b>	V1.03	19-Nov-2021
<b>Disclosure restriction</b>	Public	

---

## Revision History

Revision	Description	Approved	Date
V1.01	Initial Release	George He	2019.05.20
V1.02	11n/ac PHY rate debug	George He	2019.08.2
V1.03	Update the format and product picture	Wendy	2021.11.19

SKYLAB reserves all rights to this document and the information contained herein. Products, names, logos and designs described herein may in whole or in part be subject to intellectual property rights. Reproduction, use, modification or disclosure to third parties of this document or any part thereof without the express permission of SKYLAB is strictly prohibited.

The information contained herein is provided “as is” and SKYLAB assumes no liability for the use of the information. No warranty, either express or implied, is given, including but not limited, with respect to the accuracy, correctness, reliability and fitness for a particular purpose of the information. This document may be revised by SKYLAB at any time. For most recent documents, visit [www.skylab.com.cn](http://www.skylab.com.cn).

Copyright © 2019, Skylab M&C Technology Co., Ltd.

SKYLAB® is a registered trademark of Skylab M&C Technology Co., Ltd in China

## Contents

1. General Description.....	4
2. Applications.....	4
3. Feature.....	5
4. Application Block Diagram.....	5
5. Module Pinout and Pin Description.....	6
6. Performance Specification.....	6
7. Module Pinout.....	8
8. Electrical Characteristics.....	8
9. PCB Footprint and Dimensions.....	9
10. Manufacturing Process Recommendations.....	10
11. Reference Design Schematic.....	11
12. Packaging Specification.....	12
13. Contact Information.....	12

## 1. General Description

WG233 is a highly integrated USB Wi-Fi module which supports 867Mbps PHY rate. It is compliant with IEEE 802.11ac draft specification, offering feature-rich wireless connectivity and reliable throughput from an extended distance.

WG233 is designed to support standard based features in the areas of security, quality of service and international regulations, giving end users the greatest performance any time and in any circumstance.

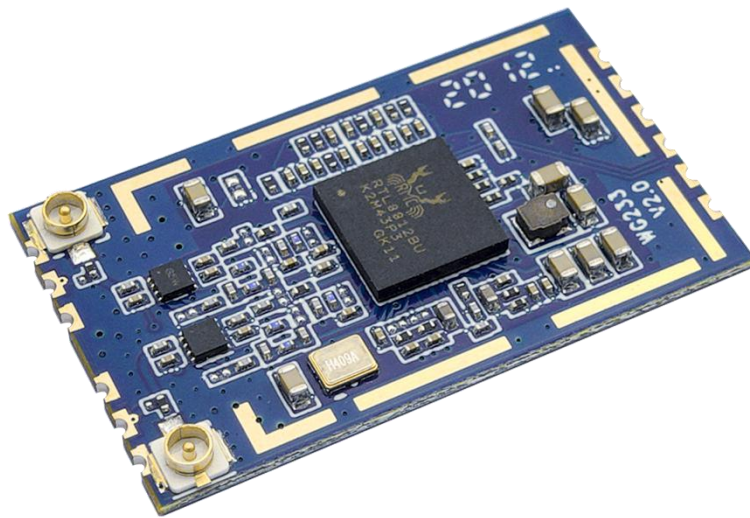

**Figure 1: WG233 Top View**

## 2. Applications

- ◆ IP Camera
- ◆ IP TV
- ◆ IP DVD(Internet VOD Player)
- ◆ Set Top Box
- ◆ Home Gateways
- ◆ Gaming Consoles
- ◆ DVR

### 3. Feature

- ◆ IEEE 802.11a/b/g/n/ac WLAN
- ◆ 2.4G /5G 2T2R mode
- ◆ With support of 867Mbps PHY rate
- ◆ IEEE 802.11e QoS Enhancement(WLAN)
- ◆ USB LPM/Selective Suspend support
- ◆ Fully compliance with USB2.0 High-speed mode.
- ◆ IEEE 802.11i(WPA, WPA2). Open, shared key, and pair-wise key authentication services
- ◆ Supports for Windows XP 32/64, 2000, Vista 32/64bit, Windows 7 32/64bit, Linux, Android
- ◆ RoHS compliance meets environment-friendly requirement.
- ◆ FCC,CE compliance
- ◆ 29.0(L) x 17.0(W) x 2.8mm small dimension.

### 4. Application Block Diagram

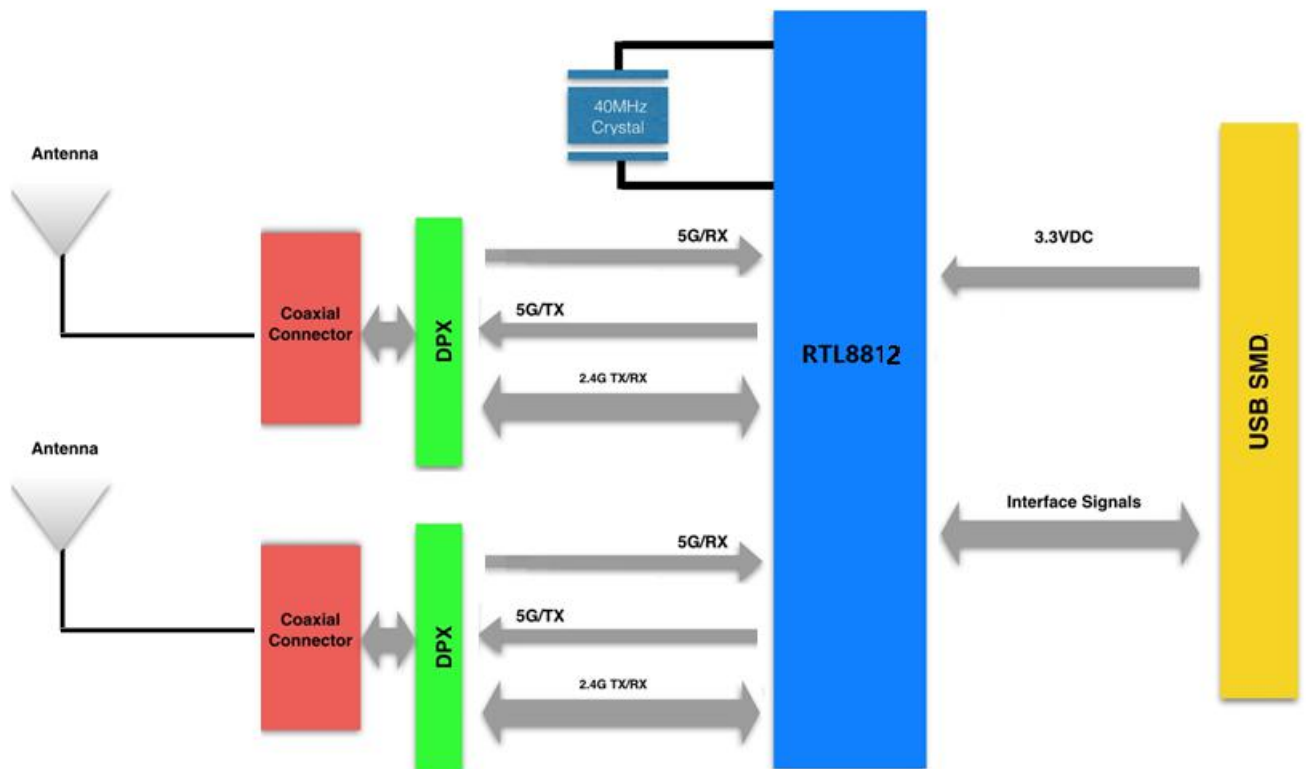

Figure 2: WG233 Block Diagram

## 5. Module Pinout and Pin Description

Module NO.	RF Connector Type	Antenna Option
WG233E	IPEX Connector	Ext Antenna
WG233P	PCB PIN	Ext Antenna

## 6. Performance Specification

Hardware Features	
Model	WG233
ANTENNA TYPE	IPEX connector or PCB antenna
Voltage	3.0—3.6V
DIMENSIONS(W×D)	29mm*17mm*2.8mm
Wireless Features	
WIRELESS STANDARDS	IEEE 802.11 a/b/g/n/ac
FREQUENCY RANGE	2.4/5GHz
DATA RATES	IEEE 802.11a Standard Mode: 6,9,12,18,24,36,48,54Mbps
	IEEE 802.11 b Standard Mode: 1,2,5.5,11Mbps
	IEEE 802.11g Standard Mode: 6,9,12,18,24,36,48,54Mbps
	IEEE 802.11n/Draft 2.0 Mode: 300Mbps @ HT40
2.4G RECEIVE SENSITIVITY	IEEE 802.11ac Standard Mode: 867Mbps @VHT80
	HT40 MCS15: -69dBm@10% PER(MCS7)
	HT20 MCS15 : -72dBm@10% PER(MCS7)
	54M: -74dBm@10% PER
5G RECEIVE SENSITIVITY	11M: -89dBm@ 8% PER
	VHT80 MCS15: -59dBm@10% PER(MCS9)
	HT40 MCS15: -68dBm@10% PER(MCS7)
	OFDM 54M: -75dBm@10% PER

	OFDM 6M: -90dBm@ 8% PER			
<b>MODULATION TECHNOLOGY</b>	802.11 Legacy b/g/n			
	DSSS (DBPSK, DQPSK, CCK)			
	OFDM (BPSK, QPSK, 16-QAM, 64-QAM)			
	802.11ac			
	OFDM (256-QAM)			
<b>WIRELESS SECURITY</b>	Supports WEP64/128, WPA, WPA2, TKIP, WAPI, and AES hardware encryption			
<b>5GHZ TRANSMIT POWER</b>	IEEE 802.11ac: 9-13dBm @AC80 MCS7			
<b>2.4GHZ TRANSMIT POWER</b>	IEEE 802.11n: 14-17dBm @HT40 MCS7			
	14-17dBm@HT20 MCS7			
	IEEE 802.11g: 15-17dBm			
	IEEE 802.11b: 16-20dBm			
<b>WORK MODE</b>	AP/Ad-Hoc / Infrastructure mode			
<b>Others</b>				
<b>POWER Consumption@25°C</b>	Status	POWER	2.4G/mA	5G/mA
	Transmission HT40/MCS 7	3.3V	300	350
	Receiving VHT80/MCS15	3.3V	90	90
<b>SYSTEM REQUIREMENTS</b>	Windows 7(32/64bits), Windows Vista(32/64bits), Windows XP(32/64bits), Windows 2000, Linux, Android			
<b>ENVIRONMENT</b>	Operating Temperature: -10°C~70°C			
	Storage Temperature: -40°C~125°C			
	Operating Humidity: 10%~90% non-condensing			
	Storage Humidity: 5%~90% non-condensing			

## 7. Module Pinout

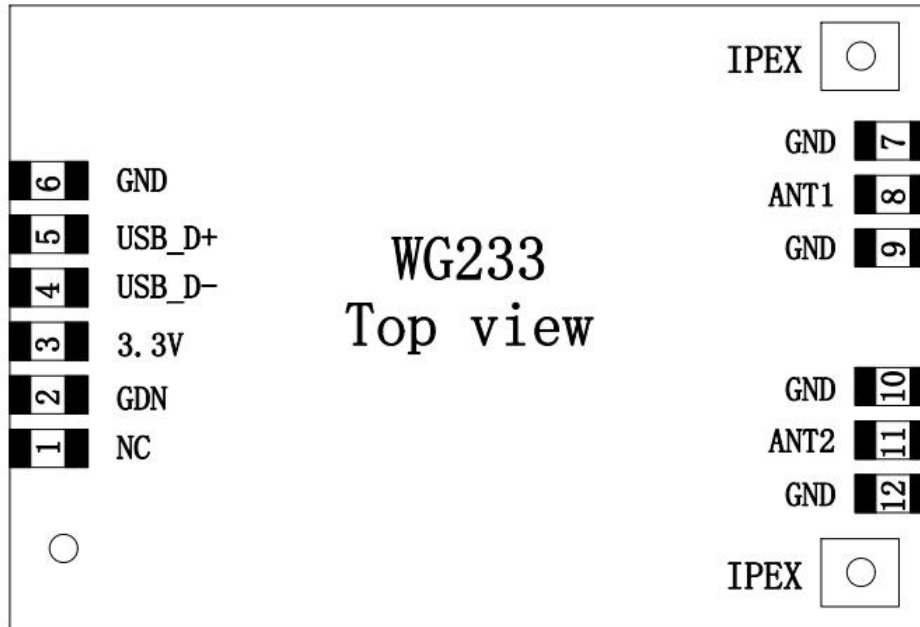

Figure 3: WG233 Pin Name

## 8. Electrical Characteristics

Pin No.	Pin name	I/O	Description	Remark
1	NC		NC	
2	GND	G	Ground	
3	3.3V	P	Module Power Supply	
4	USB_D-	I/O	USB Interface DM	
5	USB_D+	I/O	USB Interface DP	
6	GND	G	Ground	
7	GND	G	Ground	
8	ANT1	RF	Antenna1	50 OHM
9	GND	G	Ground	
10	GND	G	Ground	
11	ANT2	RF	Antenna2	50 OHM
12	GND	G	Ground	



## 9. PCB Footprint and Dimensions

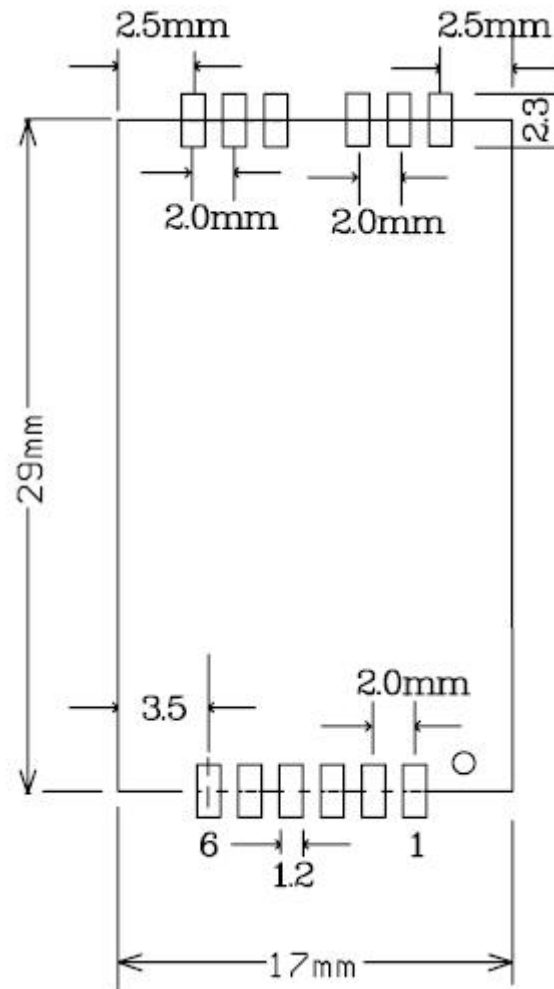

Figure 4: WG233 Dimensions

## 10. Manufacturing Process Recommendations

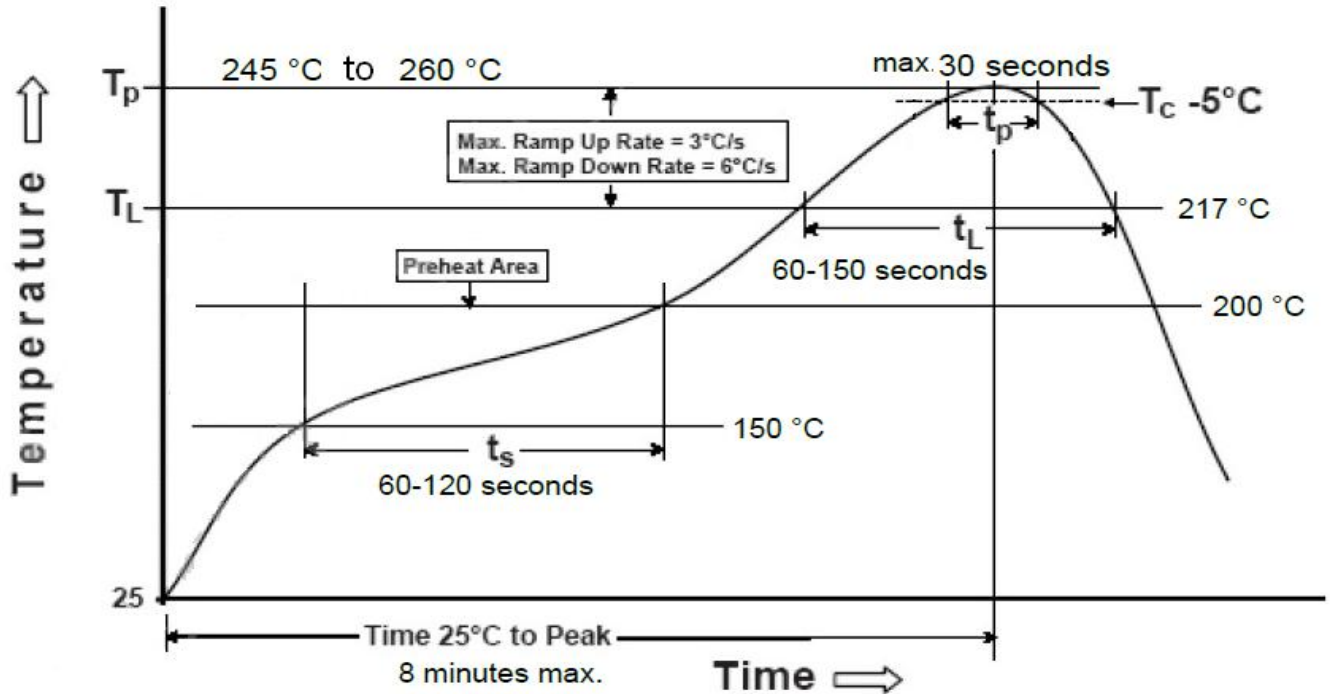

Figure 5: WG233 Typical Lead-free Soldering Profile

**Note:** The final soldering temperature chosen at the factory depends on additional external factors like choice of soldering paste, size, thickness and properties of the baseboard, etc. Exceeding the maximum soldering temperature in the recommended soldering profile may permanently damage the module.

## 11. Reference Design Schematic

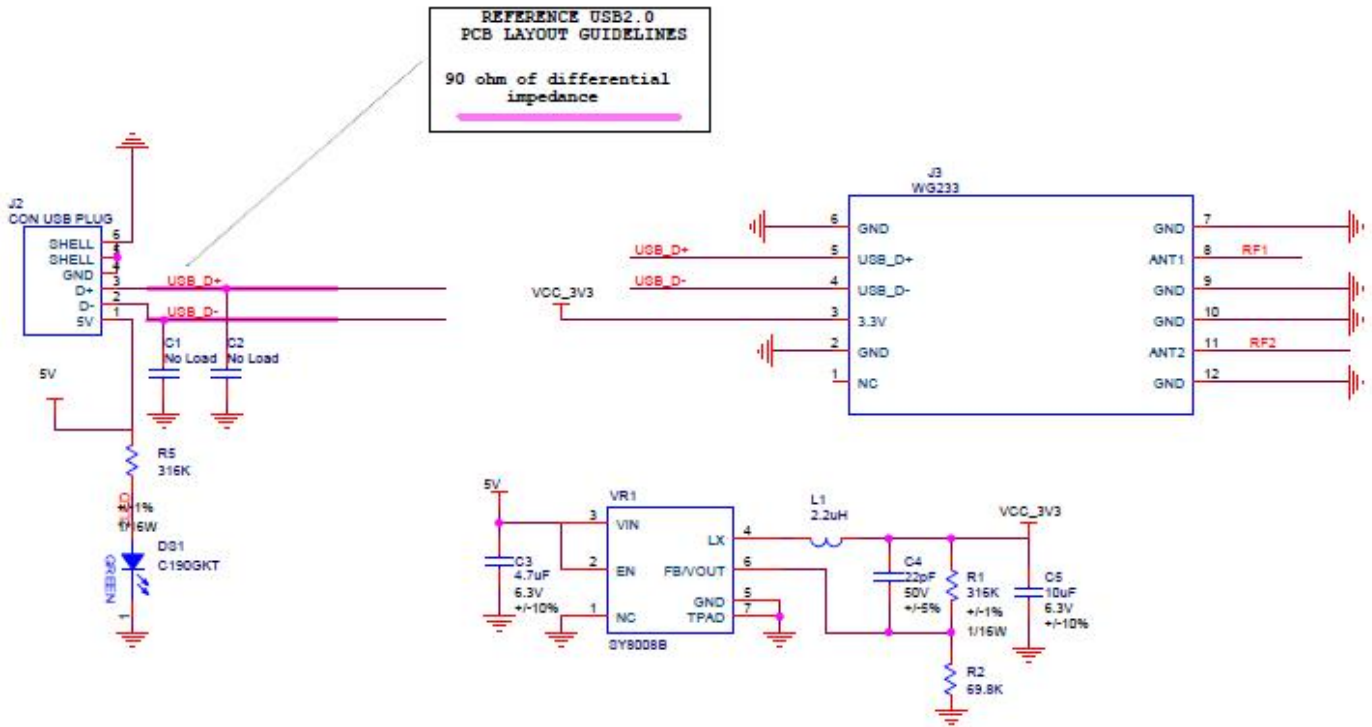

Figure 6: WG233 schematic application

## 12. Packaging Specification

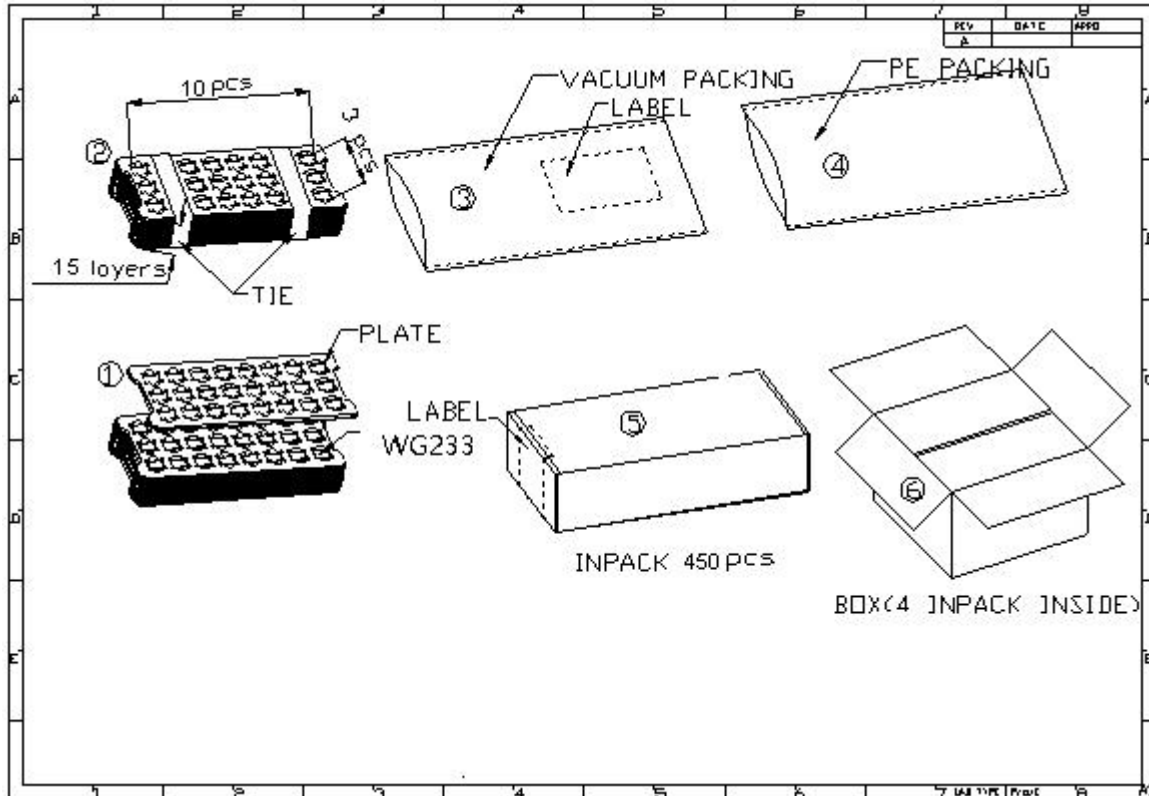

Figure 7: WG233 Packaging Specification

## 13. Contact Information

**Skylab M&C Technology Co., Ltd.**

深圳市天工测控技术有限公司

Address: 6Floor, No.9 Building, Lijincheng Scientific & Technical park, Gongye East Road,

Longhua District, Shenzhen, Guangdong, China

Phone: 86-755 8340 8210 (Sales Support)

Phone: 86-755 8340 8510 (Technical Support)

Fax: 86-755-8340 8560

E-Mail: [technicalsupport@skylab.com.cn](mailto:technicalsupport@skylab.com.cn) (Technical support)

Website: [www.skylab.com.cn](http://www.skylab.com.cn)     [www.skylabmodule.com](http://www.skylabmodule.com)