

# GPS Module

# Datasheet

Name: Ultra High Sensitivity and Low Power GPS Receiver Module

Model No.: SKG16BL

Revision: V3.02

## Revision History:

Revision	Description	Approved	Date
V1.01	Initial Release	George	20120828
V2.01	Update office's address	George	20131120
V3.01	Update firmware	Sunny	20150312
V3.02	Update certification information	George	20170831

## General Description

The SKG16BL is a complete GPS engine module that features super sensitivity, ultra low power and small form factor. The GPS signal is applied to the antenna input of module, and a complete serial data message with position, velocity and time information is presented at the serial interface with NMEA protocol or custom protocol.

It is based on the high performance features of the MediaTek MT3337 single-chip architecture, Its -165dBm tracking sensitivity extends positioning coverage into place like urban canyons and dense foliage environment where the GPS was not possible before. The small form factor and low power consumption make the module easy to integrate into portable device like PNDs, mobile phones, cameras and vehicle navigation systems.

## Applications

- LBS (Location Based Service)
- PND (Portable Navigation Device)
- Vehicle navigation system
- Mobile phone



Figure 1: SKG16BL Top View

## Features

- Ultra high sensitivity: -165dBm
- Extremely fast TTFF at low signal level
- Built-in 12 multi-tone active interference canceller
- Ultra low power consumption
- ±10ns high accuracy time pulse (1PPS)
- NMEA Output: GGA,GSA,GSV,RMC,VTG,GLL
- Support QZSS
- Advanced Features: Aiding EPO;EASY
- Small form factor: 15.9x13.1x2.2mm
- RoHS compliance (Lead-free)
- FCC,CE compliance

## Pin Assignment

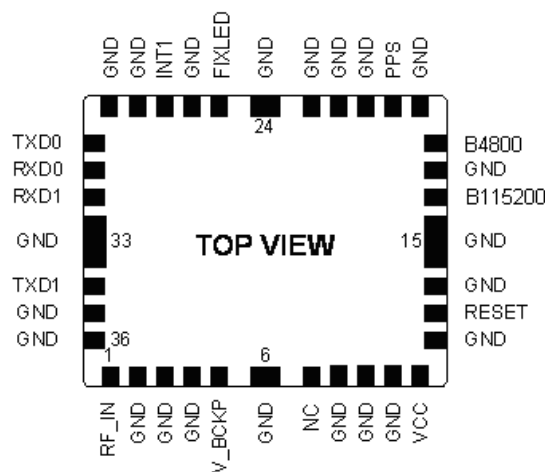

Figure 2: SKG16BL Pin Package

**Pin Description**

Pin No.	Pin name	I/O	Description	Remark
1	RF_IN	I	Antenna Input	50Ω@1.57542GHz
2	GND	G	Ground	
3	GND	G	Ground	
4	GND	G	Ground	
5	V_BCKP	I	RTC and backup SRAM power	Operating range: 2.0V to 4.2V
6	GND	G	Ground	
7	NC			
8	GND	G	Ground	
9	GND	G	Ground	
10	GND	G	Ground	
11	VCC	P	Module Power Supply	Operating range: 3.0V to 4.2V
12	GND	G	Ground	
13	RESET	I	Module Reset (Active Low Status)	Leave open if not used
14	GND	G	Ground	
15	GND	G	Ground	
16	B115200	I	UART0 Baud rate configuration pin	Leave Open if not used
17	GND	G	Ground	
18	B4800	I	UART0 Baud rate configuration pin	Leave Open if not used
19	GND	G	Ground	
20	PPS	O	Time pulse Signal (100ms)	Leave Open if not used
21	GND	G	Ground	
22	GND	G	Ground	
23	GND	G	Ground	
24	GND	G	Ground	
25	FIXLED	O	Reserved	Leave Open if not used
26	GND	G	Ground	
27	INT1	I	External Interrupt	Leave Open if not used
28	GND	G	Ground	
29	GND	G	Ground	
30	TXD0	O	UART Serial Data Output 0	Leave Open if not used
31	RXD0	I	UART Serial Data Input 0	Leave Open if not used
32	RXD1	I	UART Serial Data Input 1	Leave Open if not used
33	GND	G	Ground	
34	TXD1	O	UART Serial Data Output 1	Leave Open if not used
35	GND	G	Ground	
36	GND	G	Ground	

## Interfaces Configuration

### Power Supply

Regulated power for the SKG16BL is required. The input voltage Vcc should be 3.0V to 4.2V range, current is no less than 100mA. Suitable decoupling must be provided by external decoupling circuitry. It can reduce the Noise from power supply and increase power stability.

Main power supply Vcc current varies according to the processor load and satellite acquisition. Maximum Vcc peak current is about 30 mA during acquisition.

### Backup Battery Power

In case of a power failure on pin Vcc, real-time clock and backup RAM are supplied through pin V\_BCKP. This enables the SKG16BL GPS Receiver to recover from power failure with either a hot start or a warm start (depending on the duration of Vcc outage). If no Backup Battery is connected, the receiver performs a cold start upon powered up.

Backup Battery Power V\_BCKP draws typically 7 uA current in backup state.

### RESET

The SKG16BL modules include a RESET pin. Driving RESET low activates a hardware reset of the system. RESET is only an input and will not reset external circuitry. At power down the reset is forced when the Vcc drops below 2.7V.

#### NOTE

If not used, leave RESET not connected (floating).

### Antenna

The SKG16BL GPS receiver is designed for supporting the active antenna or passive antenna connected with pin RF\_IN. The gain of active antenna should be no more than 25dB (18~20dB Typical). The maximum noise figure should be no more than 1.5dB and output impedance is at 50 Ohm.

#### NOTE

With passive antenna keep the cable loss at minimum(<1dB).

### UART Ports

There are several function in SKG13B related to UATR communication, such as UART data transmission/receive and NMEA sentences input/output. In general, UART0 is as NMEA output and PMTK command input, UAR1 as RTCM input. The bit rates are selectable from 4800,9600,38400,115200 bps (see table).

Baud rate	Pin18:B4800	Pin16:B115200
9600bps	NC	NC
4800bps	10K pull-down	NC
115200bps	NC	10K pull-down
38400bps	10K pull-down	10K pull-down

**RF\_IN**

The transmission line must to be control impedance from RF\_IN pin to the antenna or antenna connector of your choice. (Impedance 50Ω)

**PPS**

A pulse per second (1 PPS) is an electrical signal that very precisely indicates the start of a second. Depending on the source, properly operating PPS signals have an accuracy ranging 10ns. The PPS signals are used for precise timekeeping and time measurement.

**Advanced Software Features****AIC\_Multi-tone active interference canceller**

Because different application (Wi-Fi , GSM/GPRS,3G/4G,Bluetooth )are integrated into navigation system , the harmonic of RF signal will influence the GPS reception , The multi- tone active-interference canceller can reject external RF interference which come from other active components on the main board , to improve the capacity of GPS reception without any needed HW change in the design .SKG12BL can cancel up to 12 independent channel interference continuous wave.

**EASY™**

The EASY™ is embedded assist system for quick positioning, the GPS engine will calculate and predict automatically the single emperies ( Max. up to 3 days )when power on ,and save the predict information into the memory , GPS engine will use these information for positioning if no enough information from satellites , so the function will be helpful for positioning and TTFF improvement under indoor or urban condition ,the Backup power (VBACKUP) is necessary .

**Aiding EPO**

The Aiding EPO supply the predicated Extended Prediction Orbit data to speed TTFF ,users can download the EPO data to GPS engine from the FTP server by internet or wireless network ,the GPS engine will use the EPO data to assist position calculation when the navigation information of satellites are not enough or weak signal zone .

**Performance Specification**

Parameter	Specification	
Receiver Type	L1 frequency band, C/A code, 22 Tracking / 66 Acquisition-Channel	
Sensitivity	Tracking	-165dBm Typical
	Acquisition	-148dBm Typical
Accuracy	Position	3.0m CEP50 without SA(Typical Open Sky)

	Velocity Timing (PPS)	0.1m/s without SA 10ns RMS
Acquisition Time	Cold Start Warm Start Hot Start Re-Acquisition	23s(Typical Open Sky) 23s 1s <1s
Power Consumption	Tracking Acquisition	23mA @3.3V Typical 26mA @3.3V
Navigation Data Update Rate	Max 10Hz	Default 1Hz
Operational Limits	Altitude Velocity Acceleration	Max 18,000m Max 515m/s Less than 4g

## Electrical Characteristics

### Absolute Maximum Rating

Parameter	Symbol	Min	Max	Units
<b>Power Supply</b>				
Power Supply Volt.	VCC	-0.3	4.3	V
<b>Input Pins</b>				
Input voltage on any input connection	VIO	-0.3	3.6	V
Backup Battery	V_BCKP	-0.3	4.3	V
RF input power	RF_IN		-40	dBm
Human Body Model ESD capability	RF_IN		2000	V
Machine Model ESD capability	RF_IN		100	V
<b>Environment</b>				
Storage Temperature	Tstg	-40	125	°C
Peak Reflow Soldering Temperature <10s	Tpeak		260	°C
Humidity			95	%

**Note:** Absolute maximum ratings are stress ratings only, and functional operation at the maxims is not guaranteed. Stress beyond the limits specified in this table may affect device reliability or cause permanent damage to the device. For functional operating conditions, refer to the operating conditions tables as follow.

### Operating Conditions

Parameter	Symbol	Condition	Min	Typ	Max	Units
Power supply voltage	V <sub>CC</sub>		3	3.3	4.2	V
Backup Battery	V <sub>BCKP</sub>		2	3.3	4.2	V
Power supply voltage ripple	V <sub>CC_PP</sub>	V <sub>CC</sub> =3.3V			30	mV
Supply current, Acquisition	I <sub>CC</sub>	V <sub>CC</sub> =3.3V		26		mA
Supply current, Tracking	I <sub>CC</sub>	V <sub>CC</sub> =3.3V		23		mA
Supply current, backup state	I <sub>bckp</sub>	V <sub>CC</sub> =3.3V		7		uA
Input high voltage	V <sub>IH</sub>		2		3.6	V
Input low voltage	V <sub>IL</sub>		-0.3		0.8	V
Output high voltage	V <sub>OH</sub>		2.4		3.1	V
Output low voltage	V <sub>OL</sub>		-0.3		0.4	V
Operating temperature	T <sub>opr</sub>		-40		85	°C

### Mechanical Specification

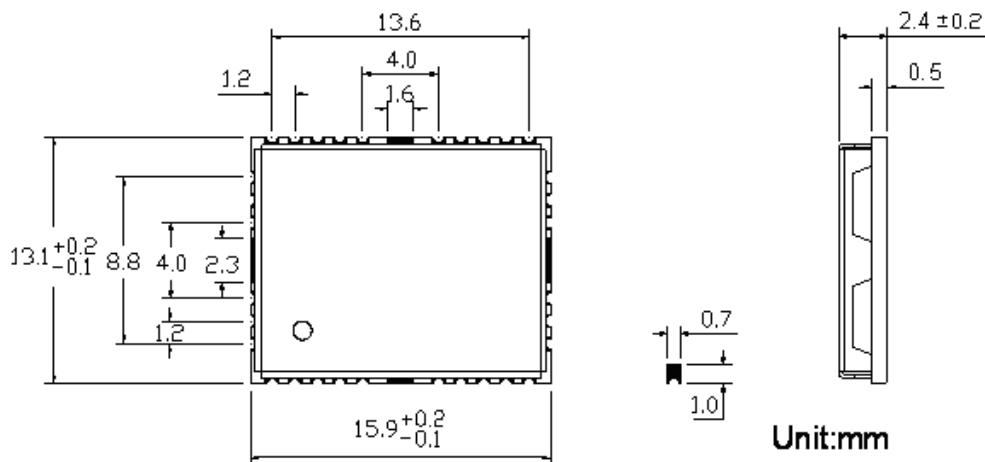
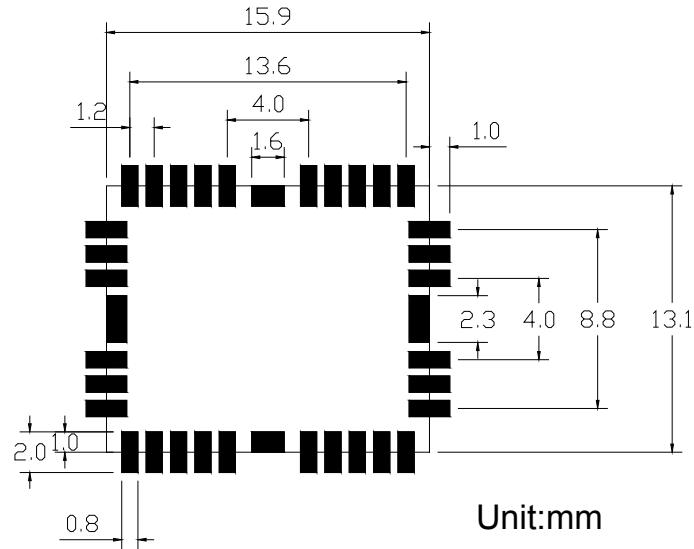

Figure 3: SKG16BL Dimensions

### Recommend Layout



**Figure 4: SKG16BL Footprint**

**Reference design schematic**

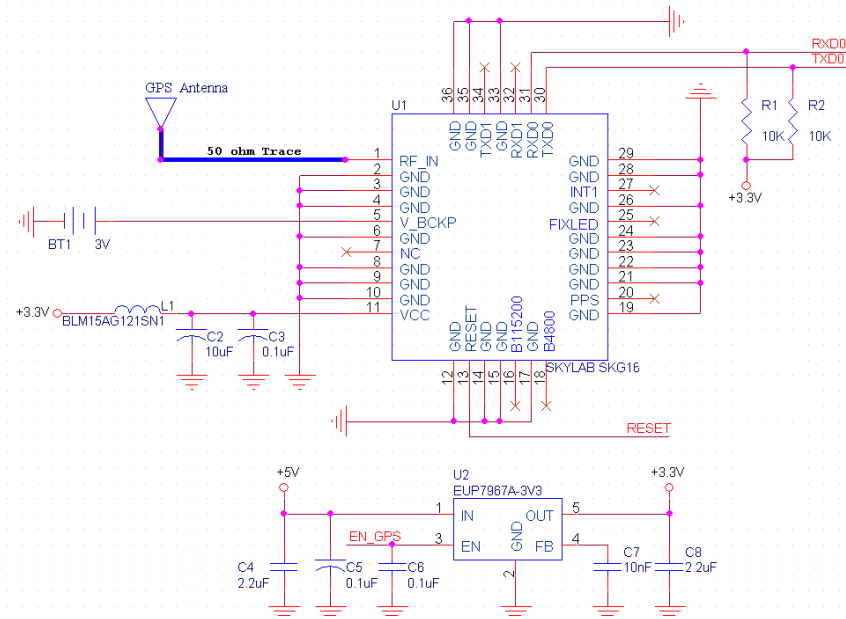

**Figure 5: SKG16BL application circuit**

**Packaging Specification**

SKG16BL modules are shipped in reel and with 1000 units per reel. Each tray is 'dry' package.



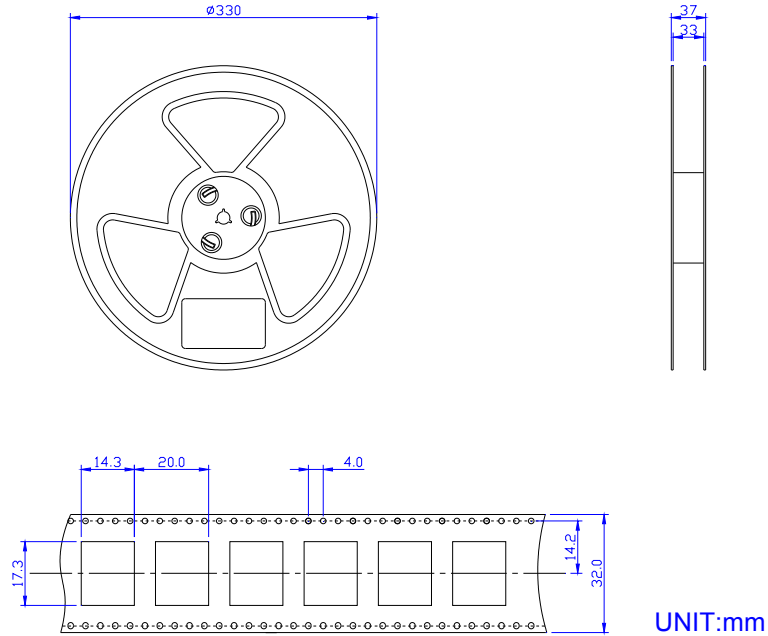

Figure 6: SKG16BL Packaging

**Manufacturing Process Recommendations**

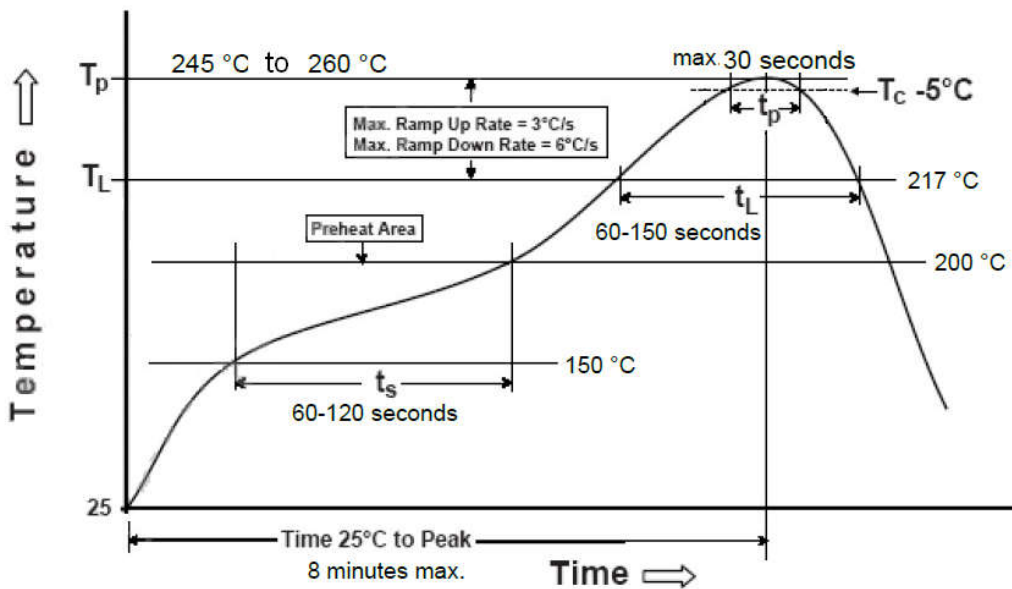

Figure 7: SKG16BL Typical Leadfree Soldering Profile

**Note:** The final soldering temperature chosen at the factory depends on additional external factors like choice of soldering paste, size, thickness and properties of the baseboard, etc. Exceeding the maximum soldering temperature in the recommended soldering profile may permanently damage the module.

## Software Protocol

### NMEA 0183 Protocol

The NMEA protocol is an ASCII-based protocol, Records start with a \$ and with carriage return/line feed. GPS specific messages all start with \$GPxxx where xxx is a three-letter identifier of the message data that follows. NMEA messages have a checksum, which allows detection of corrupted data transfers.

The Skylab SKG16BL supports the following NMEA-0183 messages: GGA, GLL, GSA, GSV, RMC VTG. The module default NMEA-0183 output is set up GGA, GLL, GSA, GSV, RMC VTG. , and default baud rate is set up 9600bps.

Table 1: NMEA-0183 Output Messages

NMEA Record	Description	Default
GGA	Global positioning system fixed data	Y
GLL	Geographic position—latitude/longitude	Y
GSA	GNSS DOP and active satellites	Y
GSV	GNSS satellites in view	Y
RMC	Recommended minimum specific GNSS data	Y
VTG	Course over ground and ground speed	Y

### GGA-Global Positioning System Fixed Data

This sentence contains the position, time and quality of the navigation fix.

See RMC for Fix Status, Fix Mode, Fix Date, Speed, and True Course.

See GSA for Fix Type, PDOP, and VDOP.

\$GPGGA,021514.000,2232.1799,N,11401.1823,E,1,6,1.25,84.0,M,-2.2,M,,\*74

Table 2: GGA Data Format

Name	Example	Units	Description
Message ID	\$GPGGA		GGA protocol header
UTC Position	021514.000		hhmmss.sss
Latitude	2232.1799		ddmm.mmmm
N/S indicator	N		N=north or S=south
Longitude	11401.1823		dddmm.mmmm
E/W Indicator	E		E=east or W=west
Position Fix Indicator	1		See Table 2-1
Satellites Used	6		Range 0 to 12
HDOP	1.25		Horizontal Dilution of Precision
MSL Altitude	84.0	meters	Altitude (referenced to the Ellipsoid)
AltUnit	M	meters	Altitude Unit
GeoSep	-2.2	meters	Geoidal Separation

GeoSepUnit	M	meters	Geoidal Separation Unit
Age of Diff.Corr.	<Null>	second	Null fields when it is not Used
Diff.Ref.Station ID	<Null>		Null fields when it is not Used
Checksum	*74		
EOL	<CR> <LF>		End of message termination

**Table 2-1: Position Fix Indicators**

Value	Description
0	Fix not available or invalid
1	GPS SPS Mode, fix valid
2	Differential GPS, SPS Mode, fix valid
3	GPS PPS Mode, fix valid

### GLL-Geographic Position – Latitude/Longitude

This sentence contains the fix latitude and longitude.

\$GPGLL,2232.1799,N,11401.1824,E,021513.000,A,A\*50

**Table 3: GLL Data Format**

Name	Example	Units	Description
Message ID	\$GPGLL		GLL protocol header
Latitude	2232.1799		ddmm.mmmm
N/S Indicator	N		N=north or S=south
Longitude	11401.1824		dddmm.mmmm
E/W Indicator	E		E=east or W=west
UTC Position	021513.000		hhmmss.sss
Fix Status	A		A=data valid or V=data not valid
Fix Mode	A		A=autonomous, N = No fix, D=DGPS, E=DR
Checksum	*50		
EOL	<CR> <LF>		End of message termination

### GSA-GNSS DOP and Active Satellites

This sentence contains the mode of operation, type of fix, PRNs of the satellites used in the solution as well as PDOP, HDOP and VDOP.

\$GPGSA,A,3,26,05,18,15,27,29,,,,,1.52,1.25,0.87\*0F

**Table 3: GSA Data Format**

Name	Example	Units	Description
Message	\$GPGSA		GSA protocol header
Mode 1	A		See Table 3-2
Mode 2	3		See Table 3-1
ID of satellite used	26		Sv on Channel 1
ID of satellite used	05		Sv on Channel 2

...	...		...
ID of satellite used	<Null>		Sv on Channel 12 (Null fields when it is not Used)
PDOP	1.52		Position Dilution of Precision
HDOP	1.25		Horizontal Dilution of Precision
VDOP	0.87		Vertical Dilution of Precision
Checksum	*0F		
EOL	<CR> <LF>		End of message termination

Table 3-1: Mode 2

Value	Description
1	Fix not available
2	2D Fix
3	3D Fix

Table 3-2: Mode 1

Value	Description
M	Manual-forced to operate in 2D or 3D mode
A	Automatic-allowed to automatically switch 2D/3D

### GSV-GNSS Satellites in View

This sentence contains the PRNs, azimuth, elevation, and signal strength of all satellites in view.

\$GPGSV,3,1,12,15,79,333,42,42,50,127,,29,45,263,44,02,36,124,30\*7E

\$GPGSV,3,2,12,26,36,226,34,05,35,046,22,27,33,161,29,21,16,319,\*7D

\$GPGSV,3,3,12,10,15,066,31,18,14,285,45,24,12,319,15,08,09,047,18\*7E

Table 4: GSV Data Format

Name	Example	Units	Description
Message ID	\$GPGSV		GSV protocol header
Number of Message	3		Total number of GSV sentences (Range 1 to 3)
Message Number	1		Sentence number of the total (Range 1 to 3)
Satellites in View	12		Number of satellites in view
Satellite ID	15		Channel 1(Range 01 to 32)
Elevation	79	degrees	Channel 1(Range 00 to 90)
Azinmuth	333	degrees	Channel 1(Range 000 to 359)
SNR(C/NO)	42	dB-Hz	Channel 1(Range 00 to 99, null when not tracking)
...			...
Satellite ID	02		Channel 4(Range 01 to 32)
Elevation	36	degrees	Channel 4(Range 00 to 90)

Azimuth	124	degrees	Channel 4(Range 000 to 359)
SNR(C/NO)	30	dB-Hz	Channel 4(Range 00 to 99, null when not tracking)
Checksum	*7E		
EOL	<CR> <LF>		End of message termination

Depending on the number of satellites tracked multiple messages of GSV data may be required.

### RMC-Recommended Minimum Specific GNSS Data

This sentence contains the recommended minimum fix information.

See GGA for Fix Quality, Sats Used, HDOP, Altitude, Geoidal Separation, and DGPS data.

See GSA for Fix Type, PDOP and VDOP.

\$GPRMC,023345.000,A,2232.1767,N,11401.1953,E,0.18,151.55,100410,,A\*6B

Table 65 RMC Data Format

Name	Example	Units	Description
Message ID	\$GPRMC		RMC protocol header
UTS Position	023345.000		hhmmss.sss
Status	A		A=data valid or V=data not valid
Latitude	2232.1767		ddmm.mmmm
N/S Indicator	N		N=north or S=south
Longitude	11401.1953		dddmm.mmmm
E/W Indicator	E		E=east or W=west
Speed Over Ground	0.18	Knots	
Course Over Ground	151.55	Degrees	True Course
Date(UTC)	100410		ddmmyy
Magnetic variation	<Null>	Degrees	Null fields when it is not Used
Magnetic Variation Direction	<Null>		E=east or W=west (Null fields when it is not Used)
Fix Mode	A		A=autonomous, N = No fix, D=DGPS, E=DR
Checksum	*6B		
EOL	<CR> <LF>		End of message termination

### VTG-Course Over Ground and Ground Speed

This sentence contains the course and speed of the navigation solution.

\$GPVTG,148.81,T,,M,0.13,N,0.24,K,A\*3D

Table 7: VTG Data Format

Name	Example	Units	Description
Message ID	\$GPVTG		VTG protocol header
Tcourse	148.81	Degrees	True Course
Reference	T		T = True

Mcourse	<Null>	Degrees	Magnetic Course (Null fields when it is not Used)
Reference	M		M = Magnetic (Null fields when it is not Used)
Speed over ground	0.13	Knots	Nautical Miles per Hour
Units	N		Knots
Speed over ground	0.24	Km/hr	in Kilometers per Hour
Units	K		Kilometer per hour
Mode	A		A=Autonomous, N=No fix, D=DGPS, E=DR
Checksum	*3D		
EOL	<CR> <LF>		End of message termination

**CMD List**

<b>CMD TYPE</b>	<b>CMD Example:</b>
Hot Restart	\$PMTK101*32<CR><LF>
Warm Restart	\$PMTK102*31<CR><LF>
Cold Restart	\$PMTK103*30<CR><LF>
Full Cold Restart	\$PMTK104*37<CR><LF>
Set baud rate	\$PMTK251,baudrate*CRC<CR><LF>

## **Skylab M&C Technology Co., Ltd.**

深圳市天工测控技术有限公司

**Address:** 6 Floor, No.9 Building, Lijincheng Scientific&Technical park, Gongye East Road, Longhua District, Shenzhen, Guangdong, China

**Phone:** 86-755 8340 8210 (Sales Support)

**Phone:** 86-755 8340 8130 (Technical Support)

**Fax:** 86-755-8340 8560

**E-Mail:** [sales1@skylab.com.cn](mailto:sales1@skylab.com.cn)

**Website:** [www.skylab.com.cn](http://www.skylab.com.cn) [www.skylabmodule.com.cn](http://www.skylabmodule.com.cn)