

SKM53 Datasheet

GPS Module

Document Information

Title	SKM53 Datasheet GPS Module	
Document type	Datasheet	
Document number	SL-20030181	
Revision and date	V1.02	22-Jul -2021
Disclosure restriction	Public	

Revision History:

Revision	Description	Approved	Date
V1.01	Initial Release	Jay	20160728
V1.02	Update the format	Wendy	20210722

SKYLAB reserves all rights to this document and the information contained herein. Products, names, logos and designs described herein may in whole or in part be subject to intellectual property rights. Reproduction, use, modification or disclosure to third parties of this document or any part thereof without the express permission of SKYLAB is strictly prohibited.

The information contained herein is provided “as is” and SKYLAB assumes no liability for the use of the information. No warranty, either express or implied, is given, including but not limited, with respect to the accuracy, correctness, reliability and fitness for a particular purpose of the information. This document may be revised by SKYLAB at any time. For most recent documents, visit www.skylab.com.cn.

Copyright © 2018, Skylab M&C Technology Co., Ltd.

SKYLAB® is a registered trademark of Skylab M&C Technology Co., Ltd in China.

Contents

Contents.....	3
1. General Description.....	4
2. Applications.....	4
3. Features.....	4
4. Pin Assignment.....	5
5. Performance Specification.....	6
6. Hardware Interfaces Configuration.....	7
7. Pin Description.....	8
8. Mechanical Specification.....	8
9. Packaging Specification.....	9
10. Software Protocol.....	9
NMEA 0183 Protocol.....	9
GLL-Geographic Position – Latitude/Longitude.....	11
GSA-GNSS DOP and Active Satellites.....	11
GSV-GNSS Satellites in View.....	12
RMC-Recommended Minimum Specific GNSS Data.....	13
VTG-Course Over Ground and Ground Speed.....	14
11. Contact Information.....	15

1. General Description

The SKYLAB SKM53 Series with embedded GPS antenna enables high performance navigation in the most stringent applications and solid fix even in harsh GPS visibility environments.

It is based on the high performance features of the MediaTek 3339 single-chip architecture, Its -165dBm tracking sensitivity extends positioning coverage into place like urban canyons and dense foliage environment where the GPS was not possible before. The 6-pin UART connector design is the easiest and convenient solution to be embedded in a portable device and receiver like PND, GPS mouse, car holder, personal locator, speed camera detector and vehicle locator.

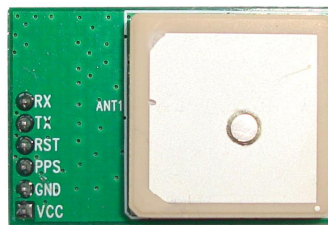

Figure 1: SKM53 Top View

2. Applications

- ◆ LBS (Location Based Service)
- ◆ Vehicle navigation system
- ◆ PND (Portable Navigation Device)
- ◆ GPS mouse and Bluetooth GPS receiver
- ◆ Timing application

3. Features

- ◆ Ultra high sensitivity: -165dBm
- ◆ 22 tracking/66 acquisition-channel receiver

- ◆ WAAS/EGNOS/MSAS/GAGAN support
- ◆ NMEA protocols (default speed: 9600bps)
- ◆ Internal back-up battery
- ◆ One serial port and USB port (option)
- ◆ Embedded patch antenna 18.2 x 18.2 x 4.0 mm
- ◆ Operating temperature range: -40 to 85°C
- ◆ RoHS compliant (Lead-free)
- ◆ Tiny form factor : 30mm x20mm x 8.5mm

4. Pin Assignment

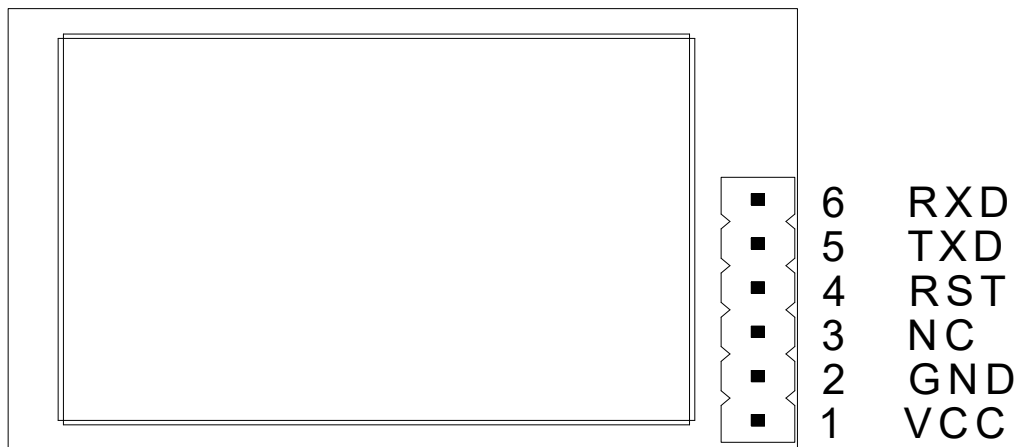

Figure 2: SKM53 Pin Package

5.Performance Specification

Parameter	Specification	
GPS receiver		
Receiver Type	L1 frequency band, C/A code, 22 Tracking / 66 Acquisition-Channel	
Sensitivity	Tracking Acquisition	-165dBm -148dBm
Accuracy	Position Velocity Timing (PPS)	3.0m CEP50 without SA(Typical Open Sky) 0.1m/s without SA 60ns RMS
Acquisition Time	Cold Start Warm Start Hot Start Re-Acquisition	23s 2-3s 1s <1s
Power Consumption	Tracking Acquisition Sleep/Standby	40mA @3.3V Typical 45mA @3.3V TBD
Navigation Data Update Rate	1Hz	
Operational Limits	Altitude Velocity Acceleration	Max 18,000m Max 515m/s Less than 4g
Antenna Specifications		
Outline Dimension	18.2 x 18.2 x 4.0 mm	
Center Frequency	1575 ± 3 MHz	
Bandwidth	10 MHz min	
Impedance	50 Ω	
Axial Ratio	3 dB max	
Polarization	RHCP	
Mechanical requirements		
Dimension	30mm x20mm x 8.5mm	
Weight	9g	
Power consumption		

VCC	3.3V~5V
Current	50mA(typical)
Environment	
Operating temperature	-40 ~ +85 °C (w/o backup battery)
Storage temperature	-40 ~ +125 °C
Humidity	≅ 95%

6. Hardware Interfaces Configuration

Power Supply: Regulated power for the SKM53 series is required. The input voltage VCC should be 5V~3.3V, current is no less than 150mA. Suitable decoupling must be provided by external decoupling circuitry(10uF and 1uF). It can reduce the Noise from power supply and increase power stability.

UART Ports: The module supports one full duplex serial channels UART. The serial connections are at 2.85V LVTTTL logic levels, if need different voltage levels, use appropriate level shifters. the data format is however fixed: X, N, 8, 1, i.e. X baud rate, no parity, eight data bits and one stop bit, no other data formats are supported, LSB is sent first. The modules default baud rate is set up 9600bps. The RXD0 & TXD0 recommended to pull up (10KΩ). It can increase the stability of serial data.

7.Pin Description

Pin	Pin name	I/	Description	Remark
UART Port				
1	VCC	P	Module Power Supply	VCC:5V~3.3V
2	GND	G	Module Power Ground	Reference Ground
3	NC	O	No Connection	Reserved for future use
4	RST	I	Module Reset (Active Low Status)	Leave Open if not used
5	TXD	O	TTL:3.1V≥VOH≥2.4V -0.3V≤VOL≤0.4V	Strap pin, default MUST pull up
6	RXD	I	TTL:3.6V≥VIH ≥2.0V -0.3V≤VIL≤0.8V	Leave Open if not used

8.Mechanical Specification

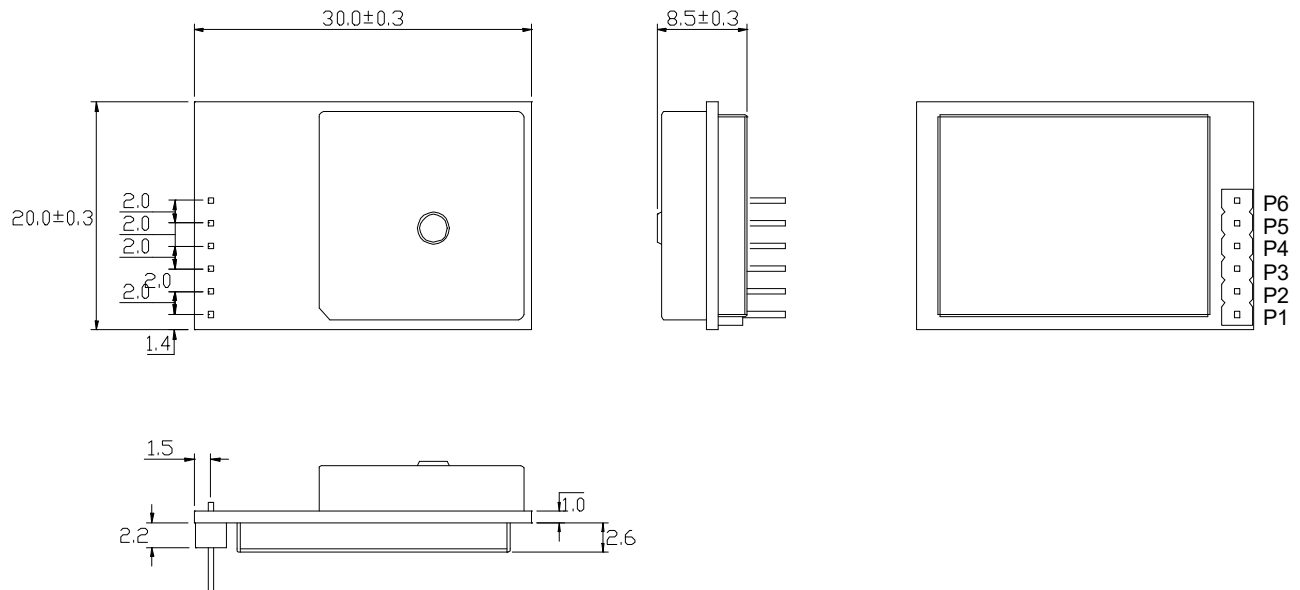

Figure 3: SKM53 Series Dimensions

9. Packaging Specification

SKM53 modules are shipped in tray and with 24 units per tray. Each tray is 'dry' package.

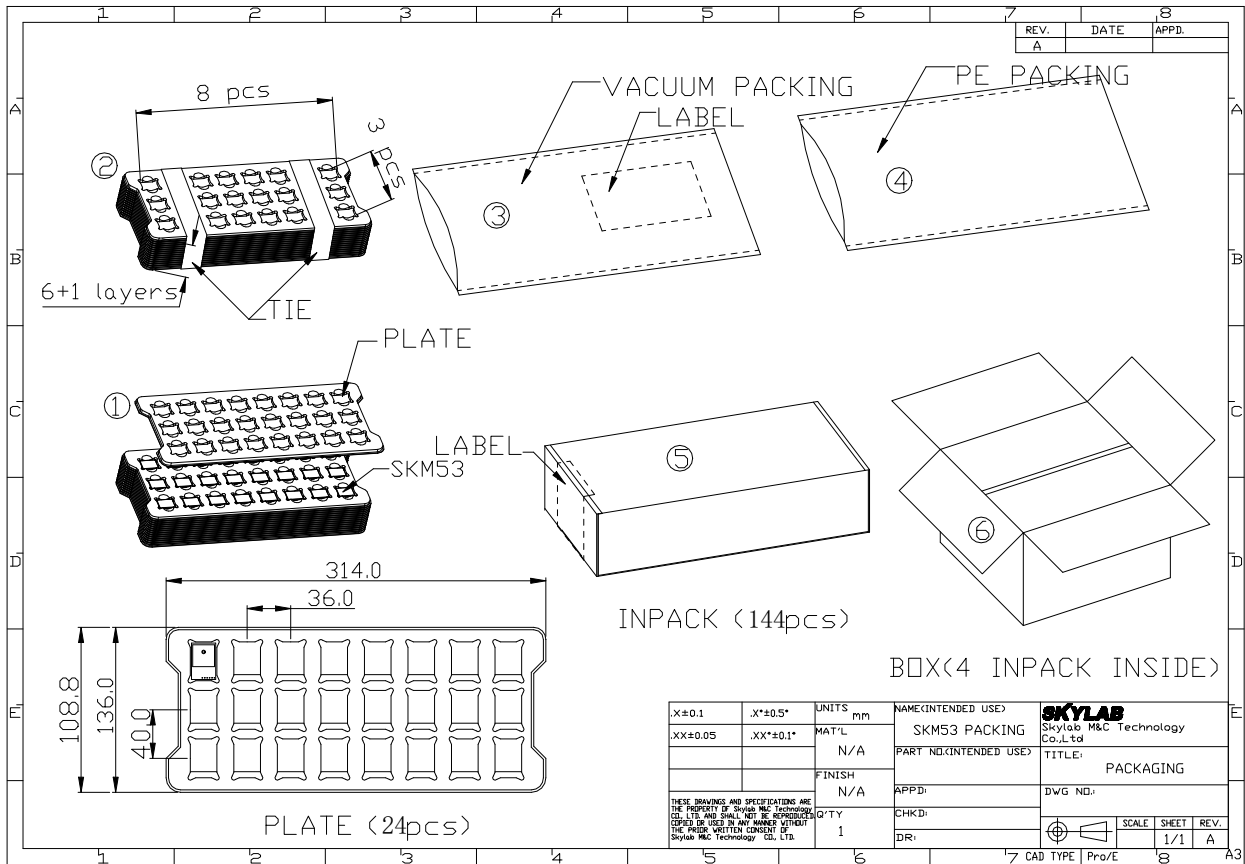

Figure 2: SKM53 Dimensions

10. Software Protocol

NMEA 0183 Protocol

The NMEA protocol is an ASCII-based protocol, Records start with a \$ and with carriage return/line feed. GPS specific messages all start with \$GPxxx where xxx is a three-letter identifier of the message data that follows. NMEA messages have a checksum, which allows detection of corrupted data transfers. The SkyNav SKM53 supports the following NMEA-0183 messages: GGA, GLL, GSA, GSV, RMC VTG, ZDA. The module default NMEA-0183 output is set up GGA、GSA、RMC、GSV , and default baud rate is set up 9600bps.

Table 1: NMEA-0183 Output Messages

NMEA Record	Description	Default
GGA	Global positioning system fixed data	Y
GLL	Geographic position—latitude/longitude	N
GSA	GNSS DOP and active satellites	Y
GSV	GNSS satellites in view	Y
RMC	Recommended minimum specific GNSS data	Y
VTG	Course over ground and ground speed	N
ZDA	Date and Time	N

GGA-Global Positioning System Fixed Data

This sentence contains the position, time and quality of the navigation fix.

See RMC for Fix Status, Fix Mode, Fix Date, Speed, and True Course.

See GSA for Fix Type, PDOP, and VDOP.

\$GPGGA,021514.000,2232.1799,N,11401.1823,E,1,6,1.25,84.0,M,-2.2,M,,*74

Table 2: GGA Data Format

Name	Example	Units	Description
Message ID	\$GPGGA		GGA protocol header
UTC Position	021514.000		hhmmss.sss
Latitude	2232.1799		ddmm.mmmm
N/S indicator	N		N=north or S=south
Longitude	11401.1823		dddmm.mmmm
E/W Indicator	E		E=east or W=west
Position Fix Indicator	1		See Table 2-1
Satellites Used	6		Range 0 to 12
HDOP	1.25		Horizontal Dilution of Precision
MSL Altitude	84.0	meters	Altitude (referenced to the Ellipsoid)
AltUnit	M	meters	Altitude Unit
GeoSep	-2.2	meters	Geoidal Separation
GeoSepUnit	M	meters	Geoidal Separation Unit
Age of Diff.Corr.	<Null>	second	Null fields when it is not Used
Diff.Ref.Station ID	<Null>		Null fields when it is not Used
Checksum	*74		

EOL	<CR> <LF>		End of message termination
-----	-----------	--	----------------------------

Table 2-1: Position Fix Indicators

Value	Description
0	Fix not available or invalid
1	GPS SPS Mode, fix valid
2	Differential GPS, SPS Mode, fix valid
3	GPS PPS Mode, fix valid

GLL-Geographic Position – Latitude/Longitude

This sentence contains the fix latitude and longitude.

\$GPGLL,2232.1799,N,11401.1824,E,021513.000,A,A*50

Table 3: GLL Data Format

Name	Example	Units	Description
Message ID	\$GPGLL		GLL protocol header
Latitude	2232.1799		ddmm.mmmm
N/S Indicator	N		N=north or S=south
Longitude	11401.1824		dddmm.mmmm
E/W Indicator	E		E=east or W=west
UTC Position	021513.000		hhmmss.sss
Fix Status	A		A=data valid or V=data not valid
Fix Mode	A		A=autonomous, N = No fix, D=DGPS, E=DR
Checksum	*50		
EOL	<CR> <LF>		End of message termination

GSA-GNSS DOP and Active Satellites

This sentence contains the mode of operation, type of fix, PRNs of the satellites used in the solution as well as PDOP, HDOP and VDOP.

\$GPGSA,A,3,26,05,18,15,27,29,,,,,,,,,1.52,1.25,0.87*0F

Table 4: GSA Data Format

Name	Example	Units	Description
Message	\$GPGSA		GSA protocol header
Mode 1	A		See Table 4-2
Mode 2	3		See Table 4-1
ID of satellite used	26		Sv on Channel 1
ID of satellite used	05		Sv on Channel 2
...
ID of satellite used	<Null>		Sv on Channel 12 (Null fields when it is not Used)
PDOP	1.52		Position Dilution of Precision
HDOP	1.25		Horizontal Dilution of Precision
VDOP	0.87		Vertical Dilution of Precision
Checksum	*0F		
EOL	<CR> <LF>		End of message termination

Table 4-1: Mode 1

Value	Description
1	Fix not available
2	2D Fix
3	3D Fix

Table 4-2: Mode 2

Value	Description
M	Manual-forced to operate in 2D or 3D mode
A	Automatic-allowed to automatically switch 2D/3D

GSV-GNSS Satellites in View

This sentence contains the PRNs, azimuth, elevation, and signal strength of all satellites in view.

\$GPGSV,3,1,12,15,79,333,42,42,50,127,,29,45,263,44,02,36,124,30*7E

\$GPGSV,3,2,12,26,36,226,34,05,35,046,22,27,33,161,29,21,16,319,*7D

\$GPGSV,3,3,12,10,15,066,31,18,14,285,45,24,12,319,15,08,09,047,18*7E

Table 5: GSV Data Format

Name	Example	Units	Description
Message ID	\$GPGSV		GSV protocol header
Number of Message	3		Total number of GSV sentences (Range 1 to 3)
Message Number	1		Sentence number of the total (Range 1 to 3)
Satellites in View	12		Number of satellites in view
Satellite ID	15		Channel 1(Range 01 to 32)
Elevation	79	degrees	Channel 1(Range 00 to 90)
Azinmuth	333	degrees	Channel 1(Range 000 to 359)
SNR(C/NO)	42	dB-Hz	Channel 1(Range 00 to 99, null when not tracking)
...			...
Satellite ID	02		Channel 4(Range 01 to 32)
Elevation	36	degrees	Channel 4(Range 00 to 90)
Azimuth	124	degrees	Channel 4(Range 000 to 359)
SNR(C/NO)	30	dB-Hz	Channel 4(Range 00 to 99, null when not tracking)
Checksum	*7E		
EOL	<CR> <LF>		End of message termination

Depending on the number of satellites tracked multiple messages of GSV data may be required.

RMC-Recommended Minimum Specific GNSS Data

This sentence contains the recommended minimum fix information.

See GGA for Fix Quality, Sats Used, HDOP, Altitude, Geoidal Separation, and DGPS data.

See GSA for Fix Type, PDOP and VDOP.

\$GPRMC,023345.000,A,2232.1767,N,11401.1953,E,0.18,151.55,100410,,A*6B

Table 6: RMC Data Format

Name	Example	Units	Description
Message ID	\$GPRMC		RMC protocol header
UTS Position	023345.000		hhmmss.sss
Status	A		A=data valid or V=data not valid

Latitude	2232.1767		ddmm.mmmm
N/S Indicator	N		N=north or S=south
Longitude	11401.1953		dddmm.mmmm
E/W Indicator	E		E=east or W=west
Speed Over Ground	0.18	Knots	
Course Over Ground	151.55	Degrees	True Course
Date(UTC)	100410		ddmmyy
Magnetic variation	<Null>	Degrees	Null fields when it is not Used
Magnetic Variation Direction	<Null>		E=east or W=west (Null fields when it is not Used)
Fix Mode	A		A=autonomous, N = No fix, D=DGPS, E=DR
Checksum	*6B		
EOL	<CR> <LF>		End of message termination

VTG-Course Over Ground and Ground Speed

This sentence contains the course and speed of the navigation solution.

\$GPVTG,148.81,T,,M,0.13,N,0.24,K,A*3D

Table 7: VTG Data Format

Name	Example	Units	Description
Message ID	\$GPVTG		VTG protocol header
Tcourse	148.81	Degrees	True Course
Reference	T		T = True
Mcourse	<Null>	Degrees	Magnetic Course (Null fields when it is not
Reference	M		M = Magnetic (Null fields when it is not Used)
Speed over ground	0.13	Knots	Nautical Miles per Hour
Units	N		Knots
Speed over ground	0.24	Km/hr	in Kilometers per Hour
Units	K		Kilometer per hour
Mode	A		A=Autonomous, N=No fix, D=DGPS, E=DR
Checksum	*3D		
EOL	<CR> <LF>		End of message termination

ZDA-Date and Time

This sentence contains UTC date & time, and local time zone offset information.

\$GPZDA,023345.000,10,04,2010,,*50

Table 8: ZDA Data Format

Name	Example	Units	Description
Message ID	\$GPZDA		ZDA protocol header
UTC Time	023345.000		hhmmss.sss
Day	10		UTC time: day (01 ... 31) dd
Month	04		UTC time: month (01 ... 12) mm
Year	2010		UTC time: year (4 digit year) yyyy
local zone hours	<null>		Local Time Zone Offset Hours (Null fields when it is not Used)
local zone minutes	<null>		Local Time Zone Offset Minutes (Null fields when it is not Used)
Checksum	*50		
EOL	<CR> <LF>		End of message termination

11. Contact Information

Skylab M&C Technology Co., Ltd.

深圳市天工测控技术有限公司

Address: 6 Floor, No.9 Building, Lijincheng Scientific & Technical park, Gongye East Road,

Longhua District, Shenzhen, Guangdong, China

Phone: 86-755 8340 8210 (Sales Support)

Phone: 86-755 8340 8510 (Technical Support)

Fax: 86-755-8340 8560

E-Mail: sales1@skylab.com.cn

Website: www.skylab.com.cn www.skylabmodule.com