

SKW95 Datasheet

IOT WLAN Module

Document Information

Title	SKW95 Datasheet IOT WLAN Module	
Document type	Datasheet	
Document number	SL-18060061	
Revision and date	V2.01	23-June-2021
Disclosure restriction	Public	

Revision History

Revision	Description	Approved	Date
V1.01	Initial Release	George	20170428
V1.02	Update certification information	George	20170831
V1.03	Update Wireless Features	George	20180605
V2.01	Update the format	Wendy	20210623

SKYLAB reserves all rights to this document and the information contained herein. Products, names, logos and designs described herein may in whole or in part be subject to intellectual property rights. Reproduction, use, modification or disclosure to third parties of this document or any part thereof without the express permission of SKYLAB is strictly prohibited.

The information contained herein is provided “as is” and SKYLAB assumes no liability for the use of the information. No warranty, either express or implied, is given, including but not limited, with respect to the accuracy, correctness, reliability and fitness for a particular purpose of the information. This document may be revised by SKYLAB at any time. For most recent documents, visit www.skylab.com.cn.

Copyright © 2017, Skylab M&C Technology Co., Ltd.

SKYLAB® is a registered trademark of Skylab M&C Technology Co., Ltd in China.

Contents

1 General Description.....	4
2 Applications.....	4
3. Features.....	5
4 Application Block Diagram.....	6
5 Interfaces.....	6
USB.....	6
I2C.....	6
SD-XC/eMMC.....	7
I2S(192K/24bits).....	7
PCM.....	9
PWM.....	10
SPI slave.....	10
UARTS lite.....	10
GPIO.....	11
WAN/LAN.....	12
6 Module Specifications.....	12
7 Module Pinout and Pin Description.....	13
Module Pinout:.....	13
Pin Description:.....	14
8 PCB Footprint and Dimensions.....	16
9 Electrical Characteristics.....	17
a) Absolute Maximum Ratings.....	17
b) Recommended Operation Ratings.....	18
c) Measurement Conditions.....	18
10 Manufacturing Process Recommendations.....	18
11 Ordering Information.....	19
12 Contact Information.....	19

1 General Description

The SKW95 module integrates a 1T1R 802.11n Wi-Fi radio, a 580MHz MIPS CPU, 1-port fast Ethernet PHY, USB2.0 host, I2C/PCM and multiple slow IOS.

The module provides two operation modes – IOT gateway mode and IOT device mode. In IOT gateway mode, the high performance USB2.0 allows SKW95 to add 3G/LTE modem support or add a H.264 ISP for wireless IP camera. For the IOT device mode, the module supports eMMC, SD-XC and USB2.0. In IOT device mode, it further supports PWM, SPI slave, 3rd UART and more GPIOs. For IOT gateway, it can connect to touch panel and BLE, Zigbee/Z-wave and sub-1G RF for smart home control.



Figure 1: SKW95 Top View

2 Applications

- ◆ IOT (internet of things)
- ◆ 3G/4G WiFi Router
- ◆ USB WiFi Camera
- ◆ Building Automation
- ◆ Home Automation
- ◆ Smart Home Gateway
- ◆ Smart Lighting
- ◆ Smart Plug
- ◆ Industry Control

3. Features

- ◆ Compliant to IEEE 802.11b/g/n.
- ◆ 1T1R 2.4GHz with support for a 150Mbps PHY data rate.
- ◆ DDR2 memory up to 1024Mb.
- ◆ Flash memory up to 256Mb.
- ◆ 4 LAN ports and 1 WAN port.
- ◆ Support USB 2.0 slave device for USB disk and USB 3G/4G dongle and USB camera.
- ◆ 24 STA-Proxy.
- ◆ Support interface: SD-XC, I2C, PCM, I2S(192K/24bits), PWM, SPI slave, UART lite, GPIO.
- ◆ Security: WEP64/128, TKIP, AES, WPA, WPA2, WAPI.
- ◆ Support IOT gateway mode and IOT device mode .
- ◆ ROHS compliance meets environment-friendly requirement.
- ◆ FCC,CE compliance
- ◆ 33.2mm(L) x 18.7mm(W) x 3.0mm(H) dimension.

4 Application Block Diagram

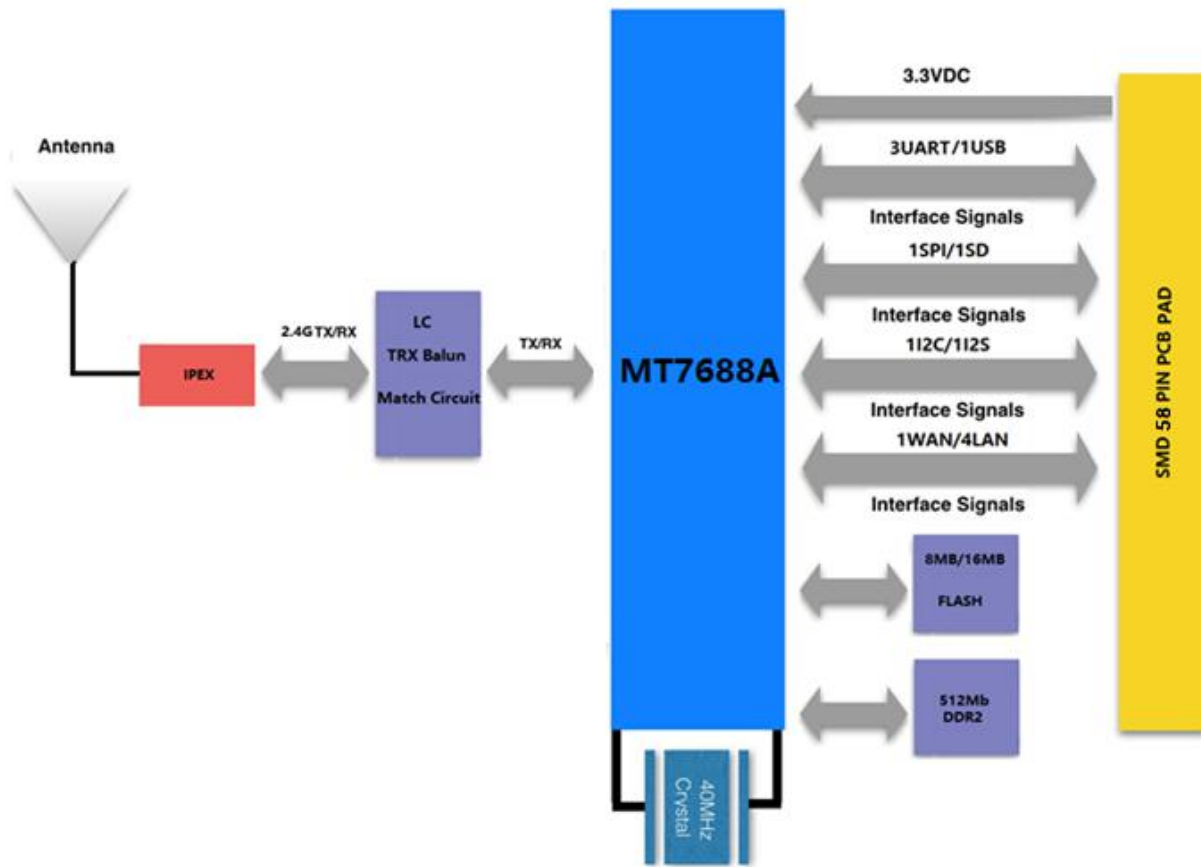

Figure 2: SKW95 Block Diagram

5 Interfaces

USB

The USB interface support USB slave devices for USB disk and USB 3G/4G dongle and USB camera.

I2C

Table5-1: I2C pin share scheme

SKW95 Pin Number	Pin Name	GPIO(2'b01)	I2C(2'b00)
49	I2C_SD	GPIO#05	I2C_SD
48	I2C_CLK	GPIO#04	I2C_CLK

Note: Controlled by I2C_MODE register

SD-XC/eMMC

Table5-2: SD-XC/eMMC pin share scheme

SKW95 Pin Number	Pin Name(4'b0000)	GPIO(2'b01)	SD(2'b00)	eMMC(2'b00)
20	LAN_PORT4_TX-	GPIO#29	SD_D2	eMMC_D3
19	LAN_PORT4_TX+	GPIO#28	SD_D3	eMMC_CMD
18	LAN_PORT4_RX-	GPIO#27	SD_CMD	eMMC_D2
17	LAN_PORT4_RX+	GPIO#26	SD_CLK	eMMC_CLK
16	LAN_PORT3_RX-	GPIO#25	SD_D0	eMMC_D0
15	LAN_PORT3_RX+	GPIO#24	SD_D1	eMMC_D1
14	LAN_PORT3_TX-	GPIO#23	SD_CD	eMMC_CD
13	LAN_PORT3_TX+	GPIO#22	SD_WP	eMMC_WP

Note: Controlled by the EPHY_APGIO_AIO_EN[4:1] and SD_MODE register

I2S(192K/24bits)

Receiver

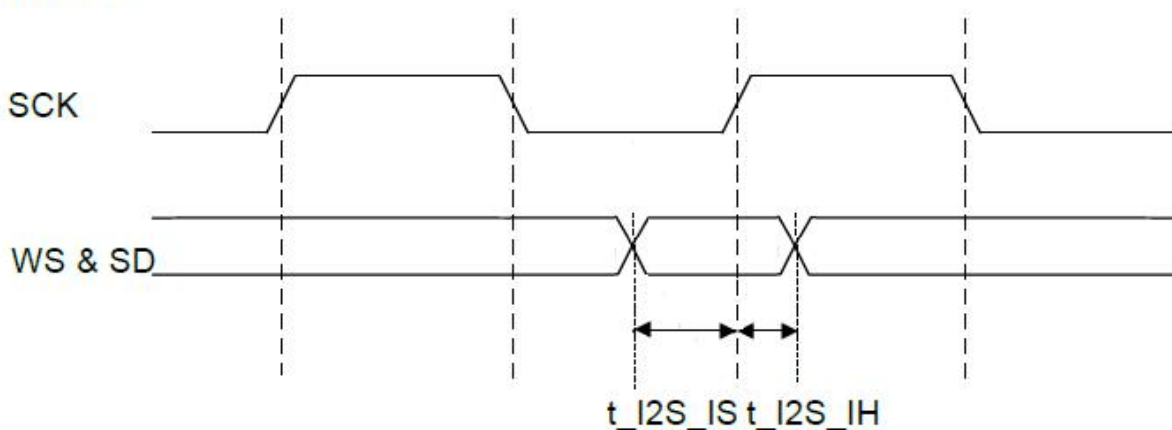

Figure 3: I2S Timing

Note: Controlled by I2S_MODE register

Table5-3: I2S/PCM pin share scheme

SKW95 Pin Number	Pin Name	GPIO(2'b01)	I2S(2'b00)	PCM(2'b10)
43	I2S_CLK	GPIO#03	I2S_CLK	PCMFS
42	I2S_WS	GPIO#02	I2S_WS	PCMCLK
41	I2S_SDO	GPIO#01	I2S_SDO	PCMDTX
40	I2S_SDI	GPIO#0	I2S_SDI	PCMDRX

Table5-4: I2S Interface Diagram Key

Symbol	Description	Min	Max	Unit
t_I2S_IS	Setup Time for I2S input(data & WS)	3.5		ns
t_I2S_IH	Hold Time for I2S input(data & WS)	0.5		ns
t_I2S_OVLD	I2S_CLK to I2S output(data & WS) valid	2.5	10	ns

PCM

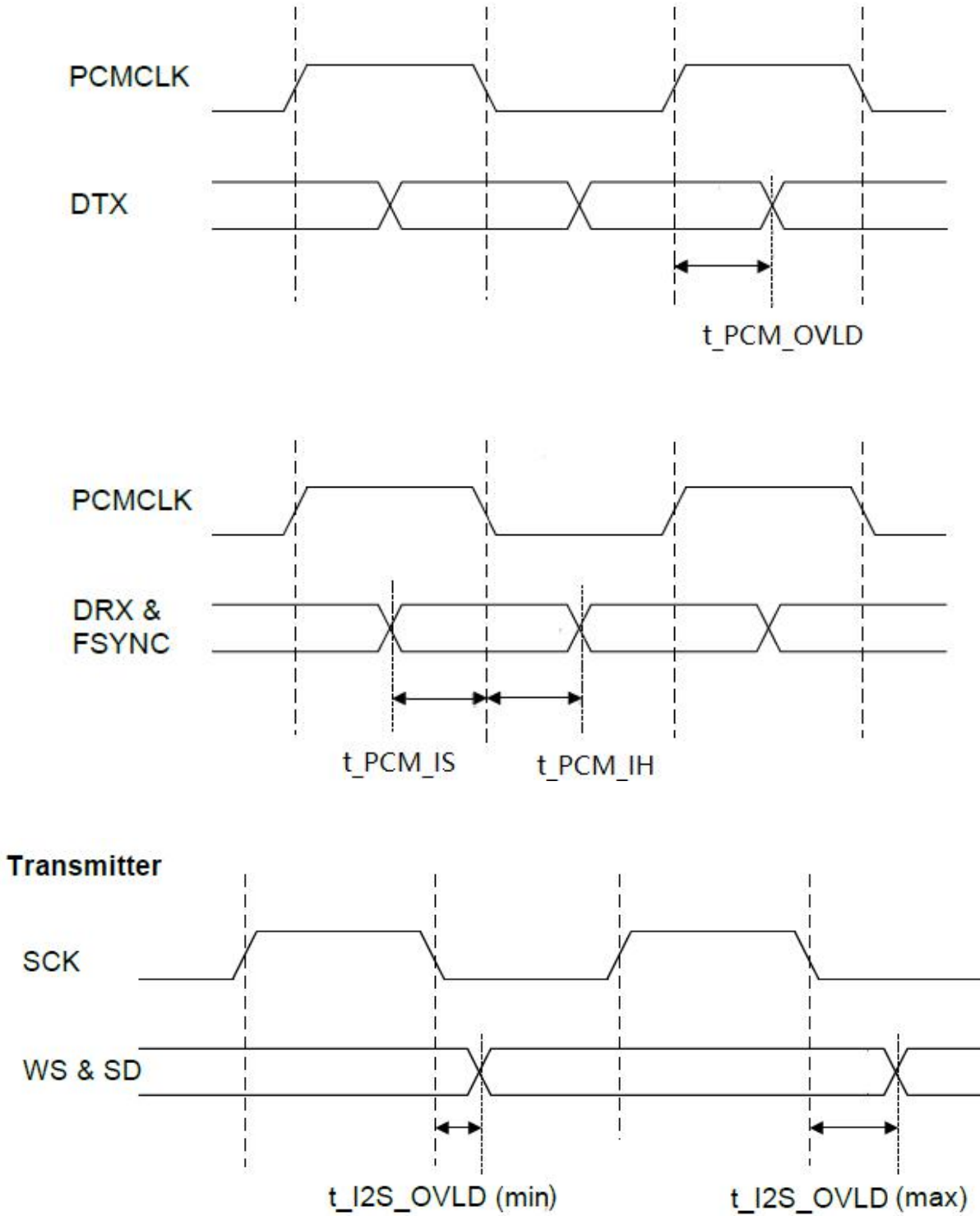

Figure 4: PCM Timing

Table5-5: PCM Interface Diagram Key

Symbol	Description	Min	Max	Unit
t_PCM_IS	Setup Time for PCM input to PCM_CLK fall	3.5		ns
t_PCM_IH	Hold Time for PCM input to PCM_CLK fall	1.0		ns
t_PCM_OVLD	PCM_CLK to PCM output valid	10.0	35.0	ns

PWM

Table5-6: PWM pin share scheme

SKW95 Pin Number	Pin Name	GPIO	PWM	Pin Share
10	LAN_PORT2_RX-	GPIO#19	PWM1	SD_D6
9	LAN_PORT2_RX+	GPIO#18	PWM0	SD_D7

SPI slave

Table5-7: SPIS pin share scheme

SKW95 Pin Number	Pin Name(4'b0000)	GPIO(2'b01)	SPIS(2'b00)	2'b11
8	LAN_PORT1_RX-	GPIO#17	SPIS_MOSI	UART_RXD2
7	LAN_PORT1_RX+	GPIO#16	SPIS_MISO	UART_TXD2
6	LAN_PORT1_TX-	GPIO#15	SPIS_CLK	PWM_CH1
5	LAN_PORT1_TX+	GPIO#14	SPIS_CS	PWM_CH0

Note: Controlled by the EPHY_APGIO_AIO_EN[4:1] and SPIS_MODE register

UARTS lite

The module support 3UART:

Table5-8: UART pin share scheme

SKW95 Pin Number	Pin Name	GPIO	UART	Pin Share
56	UART_RXD0	GPIO#13	UART0_RXD	UART0(For Debug)
55	UART_TXD0	GPIO#12	UART0_TXD	
39	UART_RXD1	GPIO#46	UART1_RXD	PWM_CH1
38	UART_TXD1	GPIO#45	UART1_TXD	PWM_CH0
12	LAN_PORT2_TX-	GPIO#21	UART2_RXD	PWM_CH3/SD_D4
11	LAN_PORT2_TX+	GPIO#20	UART2_TXD	PWM_CH2/SD_D5

GPIO

Table5-9: GPIO pin share scheme

SKW95 Pin Number	GPIO	Description	Share function
39	GPIO#46	Uart1_RXD	UART1
38	GPIO#45	Uart1_TXD	
57	GPIO#44	WLED_N	Wireless LED
36	GPIO#43	P0_LED	Port LED
35	GPIO#42	P1_LED	
34	GPIO#41	P2_LED	
33	GPIO#40	P3_LED	
32	GPIO#39	P4_LED	
31	GPIO#38	WDT_RST_N	WPS/Factory Setting
29	GPIO#37	I2S_MCLK output	WPS_LED /I2S_MCLK PIO#37
20	GPIO#29	MDI_TN_P4	SD-XC/eMMC
19	GPIO#28	MDI_TP_P4	
18	GPIO#27	MDI_RN_P4	
17	GPIO#26	MDI_RP_P4	
16	GPIO#25	MDI_RN_P3	
15	GPIO#24	MDI_RP_P3	
14	GPIO#23	MDI_TN_P3	
13	GPIO#22	MDI_TP_P3	
12	GPIO#21	MDI_TN_P2	UART2
11	GPIO#20	MDI_TP_P2	
10	GPIO#19	MDI_RN_P2	PWM1
9	GPIO#18	MDI_RP_P2	PWM0
8	GPIO#17	MDI_RN_P1	SPIS
7	GPIO#16	MDI_RP_P1	
6	GPIO#15	MDI_TN_P1	
5	GPIO#14	MDI_TP_P1	

56	GPIO#13	UART0_RXD	Uart0(For Debug)
55	GPIO#12	UART0_TXD	
47	GPIO#11	GPIO0	GPIO0
49	GPIO#05	I2C_SD	I2C
48	GPIO#04	I2C_CLK	
43	GPIO#03	I2S_CLK/PCMFS	I2S/PCM
42	GPIO#02	I2S_WS/PCMCLK	
41	GPIO#01	I2S_SDO/PCMDTX	
40	GPIO#0	I2S_SDI/PCMDRX	

WAN/LAN

In IoT gateway mode, the module integrates 5-port 10/100Mbps fast Ethernet switches; in IoT device mode, the module integrates 1-port 10/100Mbps fast Ethernet switch.

6 Module Specifications

Hardware Features	
Model	SKW95
Antenna Type	IPEX
Chipset solution	
Voltage	3.3V±5%
Dimension(L×W×H)	33.2mm*18.7mm*3.0mm
Wireless Features	
Wireless Standards	IEEE 802.11b/g/n
Frequency Range	2.412GHz---2.484 GHz
Data Rates	IEEE 802.11b : 1,2,5.5,11Mbps
	IEEE 802.11g : 6,9,12,18,24,36,48,54Mbps
	IEEE 802.11n : MCS0--MCS7 @ HT20
	MCS0--MCS7 @ HT40
Receiver Sensitivity	HT40 MCS7 : -70dBm@10% PER(MCS7)
	HT20 MCS7 : -73dBm@10% PER(MCS7)
	54M: -77dBm@10% PER

	11M: -89dBm@ 8% PER
Modulation Technique	DSSS (DBPSK, DQPSK, CCK)
	OFDM (BPSK, QPSK, 16-QAM, 64-QAM)
Wireless Security	WPA/WPA2, WEP, TKIP and AES, WPS2.0, WAPI
Transmit Power	IEEE 802.11n: 16dBm @HT20/40 MCS7
	IEEE 802.11g: 16dBm @54MHz
	IEEE 802.11b: 18dBm @11MHz
Work Mode	IoT Gateway/IoT Device
Others	
Certification	RoHS
Environment	Operating Temperature: -20°C~55°C
	Storage Temperature: -40°C~125°C
	Operating Humidity: 10%~90% non-condensing
	Storage Humidity: 5%~90% non-condensing

7 Module Pinout and Pin Description

Module Pinout:

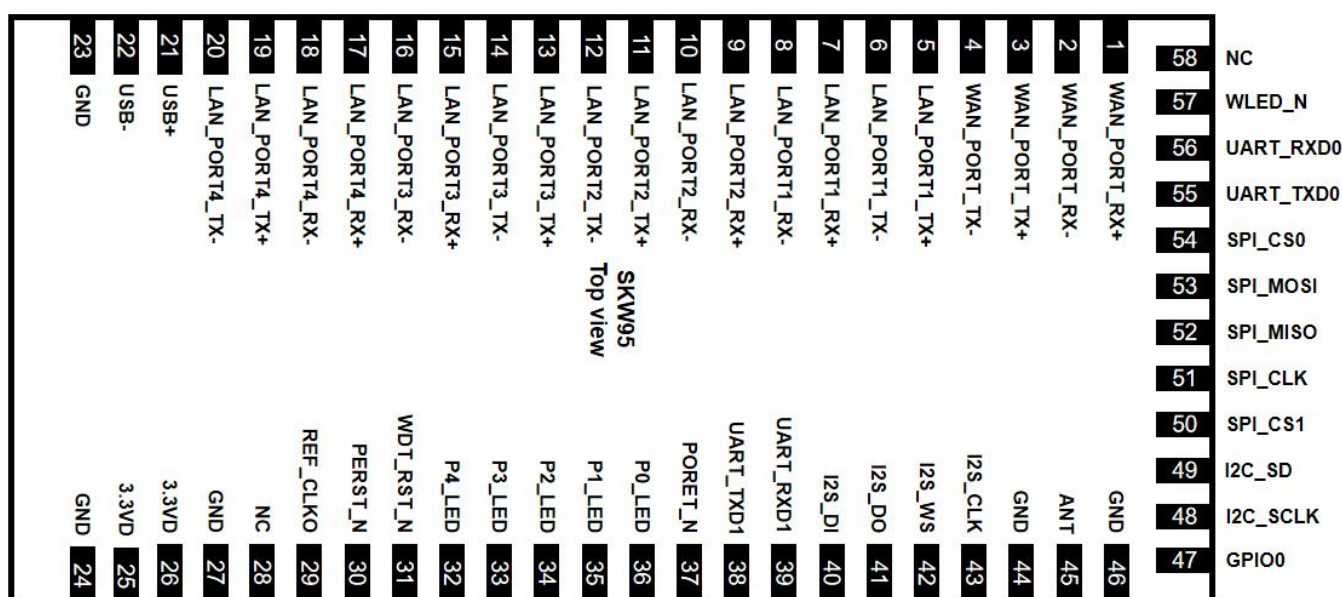

Figure 5:SKW95 Pin Packag

Pin Description:

Pin No.	Pin name	Description	Remark
1	WAN_PORT_RX+	WAN port	WAN_RX+
2	WAN_PORT_RX-	WAN port	WAN_RX-
3	WAN_PORT_TX+	WAN port	WAN_TX+
4	WAN_PORT_TX-	WAN port	WAN_TX-
5	LAN_PORT1_TX+	Ethernet port1	SPIS_CS / GPIO#14 / PWM0
6	LAN_PORT1_TX-	Ethernet port1	SPIS_CLK / GPIO#15 / PWM1
7	LAN_PORT1_RX+	Ethernet port1	SPIS_MISO / GPIO#16 / UART2_TXD
8	LAN_PORT1_RX-	Ethernet port1	SPIS_MOSI / GPIO#17 / UART2_RXD
9	LAN_PORT2_RX+	Ethernet port2	GPIO#18 / PWM0 / SD_D7
10	LAN_PORT2_RX-	Ethernet port2	GPIO#19 / PWM1 / SD_D6
11	LAN_PORT2_TX+	Ethernet port2	GPIO#20 / PWM2 / UART2_TXD / SD_D5
12	LAN_PORT2_TX-	Ethernet port2	GPIO#21 / PWM3 / UART2_RXD / SD_D4
13	LAN_PORT3_TX+	Ethernet port3	SD_WP / GPIO#22
14	LAN_PORT3_TX-	Ethernet port3	SD_CD / GPIO#23
15	LAN_PORT3_RX+	Ethernet port3	SD_D1 / GPIO#24
16	LAN_PORT3_RX-	Ethernet port3	SD_D0 / GPIO#25
17	LAN_PORT4_RX+	Ethernet port4	SD_CLK / GPIO#26
18	LAN_PORT4_RX-	Ethernet port4	SD_CMD/ GPIO#27
19	LAN_PORT4_TX+	Ethernet port4	SD_D3 / GPIO#28
20	LAN_PORT4_TX-	Ethernet port4	SD_D2 / GPIO#29
21	USB+	USB data pin Data+	USB_D+
22	USB-	USB data pin Data-	USB_D-
23	GND	Ground	GND
24	GND	Ground	GND
25	3.3VDD	3.3V input 800mA	+3.3V

26	3.3VDD	3.3V input 800mA	+3.3V
27	GND	Ground	GND
28	NC	Not Connect	
29	REF_CLKO	I2S_MCLK output	WPS_LED /I2S_MCLK / GPIO#37
30	PERST_N	PCIE Reset	
31	WDT_RST_N	WPS/Factory Setting_Button_Key	WDT_RST_N /I2S_MCLK / GPIO#38/O, IPU
32	P4_LED	LAN_PORT4_LED	P4_LED_N / GPIO#39
33	P3_LED	LAN_PORT3_LED	P3_LED_N / GPIO#40
34	P2_LED	LAN_PORT2_LED	P2_LED_N /GPIO#41
35	P1_LED	LAN_PORT1_LED	P1_LED_N/ GPIO#42
36	P0_LED	WAN_PORT_LED	P0_LED_N / GPIO#43
37	PORET_N	Power on reset	HW_RESET_N#
38	UART_TXD1	UART1 Serial Data Output	UART1_TXD / GPIO#45 / O, IPU
39	UART_RXD1	UART 1 Serial Data Input	UART1_RXD / GPIO#46
40	I2S_DI	I2S data input	I2S_SDI/GPIO#0/PCMDRX
41	I2S_DO	I2S data output	I2S_SDO /GPIO#1/PCMDTX/IPD
42	I2S_WS	I2S word select	I2S_WS/GPIO#2/PCMCLK
43	I2S_CLK	I2S clock	I2S_CLK/GPIO#3/PCMFS
44	GND	Ground	GND
45	ANT	RF ANT	
46	GND	Ground	GND
47	GPIO0	General Purpose I/O	POWER_ON# / GPIO#11/IPD
48	I2C_SCLK	I2C clock	I2C_SCL(PU 2K2) / GPIO#4
49	I2C_SD	I2C Data	I2C_SDA(PU 2K2) / GPIO#5
50	SPI_CS1	SPI chip select1	
51	SPI_CLK	SPI clock	
52	SPI_MISO	SPI Master input/Slave	

53	SPI_MOSI	SPI Master output/Slave	
54	SPI_CS0	SPI chip select0	
55	UART_TXD0	UART0 only for debug	UART0_TX / GPIO#12 / O, IPD
56	UART_RXD0	UART0 only for debug	UART0_RX / GPIO#13
57	WLED_N	Wireless LED	WLED_N / GPIO#44
58	NC	Not Connect	

Note: The red color in the pin name column indicates that the activation of the chip is related to the boot of the chip, and the outside cannot be pulled up or pulled down.

8 PCB Footprint and Dimensions

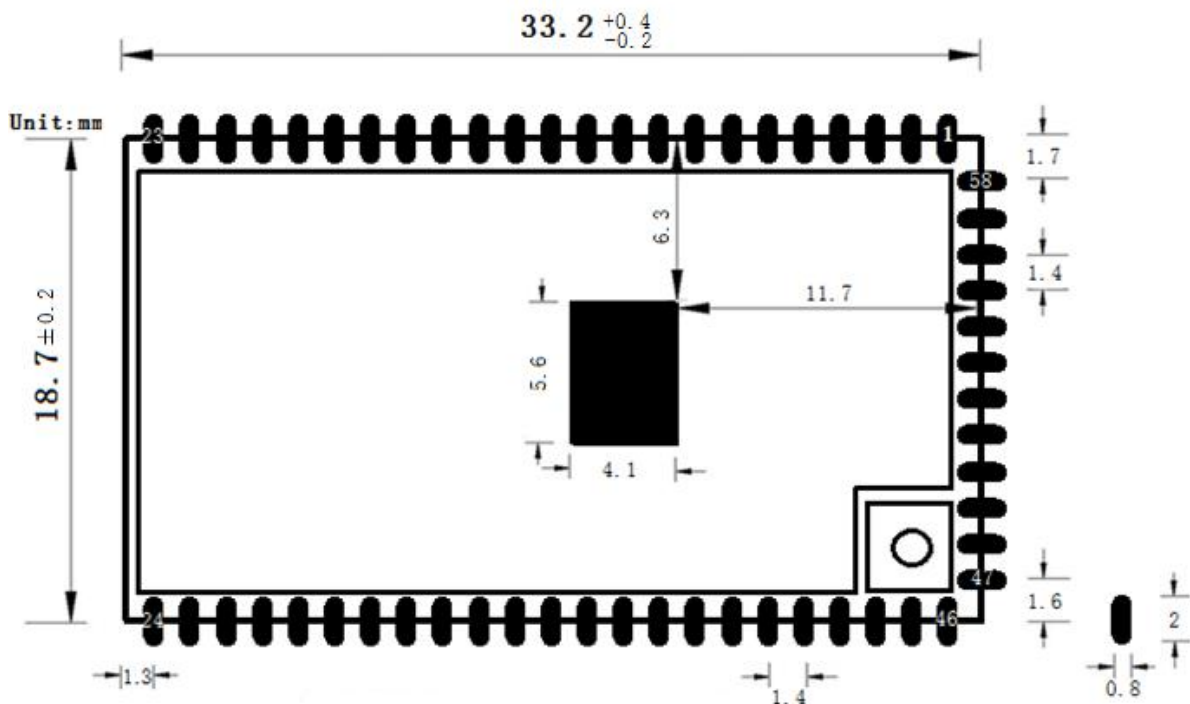

Figure 6: SKW95 Recommend PCB Footprint

Note: In the middle pad is hot soldering plates, connect to GND.

9 Electrical Characteristics

a) Absolute Maximum Ratings

Table9-1: Absolute Maximum Ratings

Parameter	Condition	Min	Typ.	Max.	Unit
Storage temperature range		-40		125	°C
ESD Protection	VESD	/		2000	V
Supply voltage	VDD_3.3V	0		3.6	V
Voltage on any I/O pin		-0.3		3.63	V

Note: Absolute maximum ratings are stress ratings only, and functional operation at the maxims is not guaranteed. Stress beyond the limits specified in this table may affect device reliability or cause permanent damage to the device. For functional operating conditions, refer to the operating conditions tables as follow.

*SKW95 series modules are Electrostatic Sensitive Devices and require special precautions while handling.



ESD precautions

The SKW95 series modules contain highly sensitive electronic circuitry and are Electrostatic Sensitive Devices (ESD). Handling the SKW95 series modules without proper ESD protection may destroy or damage them permanently.

The SKW95 series modules are electrostatic sensitive devices (ESD) and require special ESD precautions typically applied to ESD sensitive components. Proper ESD handling and packaging procedures must be applied throughout the processing, handling, transportation and operation of any application that incorporates the SKW95 series module. Don't touch the module by hand or solder with non-anti-static soldering iron to avoid damage to the mode.

Note: The final soldering temperature chosen at the factory depends on additional external factors like choice of soldering paste, size, thickness and properties of the baseboard, etc. Exceeding the maximum soldering temperature in the recommended soldering profile may permanently damage the module.

11 Ordering Information

Module No.	DDR2	SPI Flash Size
SKW95_8	512Mb	8M Bytes
SKW95_16	512Mb	16M Bytes
SKW95_32	1024Mb	32M Bytes

12 Contact Information

Skylab M&C Technology Co., Ltd.

深圳市天工测控技术有限公司

Address: 6 Floor, No.9 Building, Lijincheng Scientific & Technical park, Gongye East Road,
Longhua District, Shenzhen, Guangdong, China

Phone: 86-755 8340 8210 (Sales Support)

Phone: 86-755 8340 8510 (Technical Support)

Fax: 86-755-8340 8560

E-Mail: sales1@skylab.com.cn

Website: www.skylab.com.cn www.skylabmodule.com