

SKW77 Datasheet

High-Power WLAN Module

Document Information

Title SKW77 Datasheet High-Power WLAN Module

Document type Datasheet

Document number SL-19090136

Revision and date V2.03 15-July-2021

Disclosure restriction Public

Revision History:

Revision	Description	Approved	Date
V1.01	Initial Release	George He	20150125
V1.02	Update Order Information	George He	20150814
V1.03	Update Pin Description	George He	20160504
V2.01	Add GPIO Information	George He	20170315
V2.02	Add GPIO Information	George He	20191008
V2.03	Update the format	Wendy	20210715

SKYLAB reserves all rights to this document and the information contained herein. Products, names, logos and designs described herein may in whole or in part be subject to intellectual property rights. Reproduction, use, modification or disclosure to third parties of this document or any part thereof without the express permission of SKYLAB is strictly prohibited.

The information contained herein is provided "as is" and SKYLAB assumes no liability for the use of the information. No warranty, either express or implied, is given, including but not limited, with respect to the accuracy, correctness, reliability and fitness for a particular purpose of the information. This document may be revised by SKYLAB at any time. For most recent documents, visit www.skylab.com.cn.

Copyright © 2018, Skylab M&C Technology Co., Ltd.

SKYLAB® is a registered trademark of Skylab M&C Technology Co., Ltd in China.

Contents

1	General Description.....	4
2	Applications.....	4
3	Features.....	5
4	Application Block Diagram.....	6
5	Interfaces.....	7
	5.1 USB.....	7
	5.2 SD.....	7
	5.3 I2S.....	7
	5.4 UARTS lite.....	9
	5.5 WAN/LAN.....	9
6	Module Specifications.....	9
7	Module Pinout and Pin Description.....	11
8	PCB Footprint and Dimensions.....	14
9	Electrical Characteristics.....	14
10	Ordering Information.....	15
11	Contact Information.....	16

1 General Description

The SKW77 is a highly power WIFI module, it compliant to 802.11 b/g/n Wi-Fi Solution for highly performance WLAN requiring up to +27dBm output power. The module requiring a external 3.3V power supply and a external 5.0V power supply .

The module based on the single chip MT7620A which integrates an 802.11n 2x2 MAC/BB/radio. It supports 802.11n operations up to 144Mbps for 20 MHz and 300Mbps for 40 MHz channel respectively, and IEEE 802.11b/g data rates.

The module support bridge mode and AP client mode and router mode.

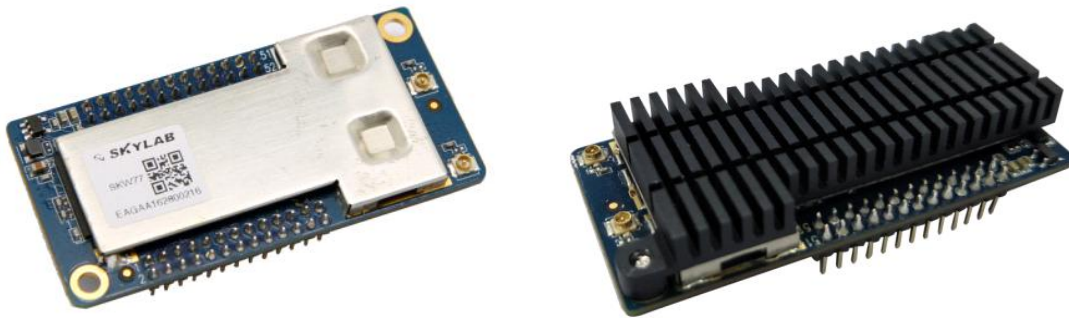

Figure 1: SKW77 Top View

2 Applications

- ◆ USB WiFi Camera PND (Portable Navigation Device)
- ◆ Wireless industrial data transmission over a long distance Mobile phone
- ◆ WiFi AP
- ◆ 3G/4G Wi-Fi Router
- ◆ WiFi Repeater
- ◆ Building Automation
- ◆ Drone

- ◆ Industry Control

3 Features

- ◆ Compliant to IEEE 802.11b/g/n Ultra high sensitivity: -165dBm
- ◆ 2T2R mode with support for a 300Mbps PHY data rate.
- ◆ Transmit power up to +28dBm
- ◆ Flash memory up to 128Mb.
- ◆ 2 LAN ports and 1 WAN port.
- ◆ Support USB 2.0 slave device for USB disk and USB 3G/4G dongle and USB camera
- ◆ Support SD card
- ◆ Support interface: I2S, UART lite, GPIO.
- ◆ Security: WEP64/128, TKIP, AES, WPA, WPA2, WAPI.
- ◆ Support Bridge/AP Client/Router mode.
- ◆ ROHS compliance meets environment-friendly requirement.
- ◆ 59.0mm(L) x 28.9mm(W) x 9.0mm(H) dimension.

4 Application Block Diagram

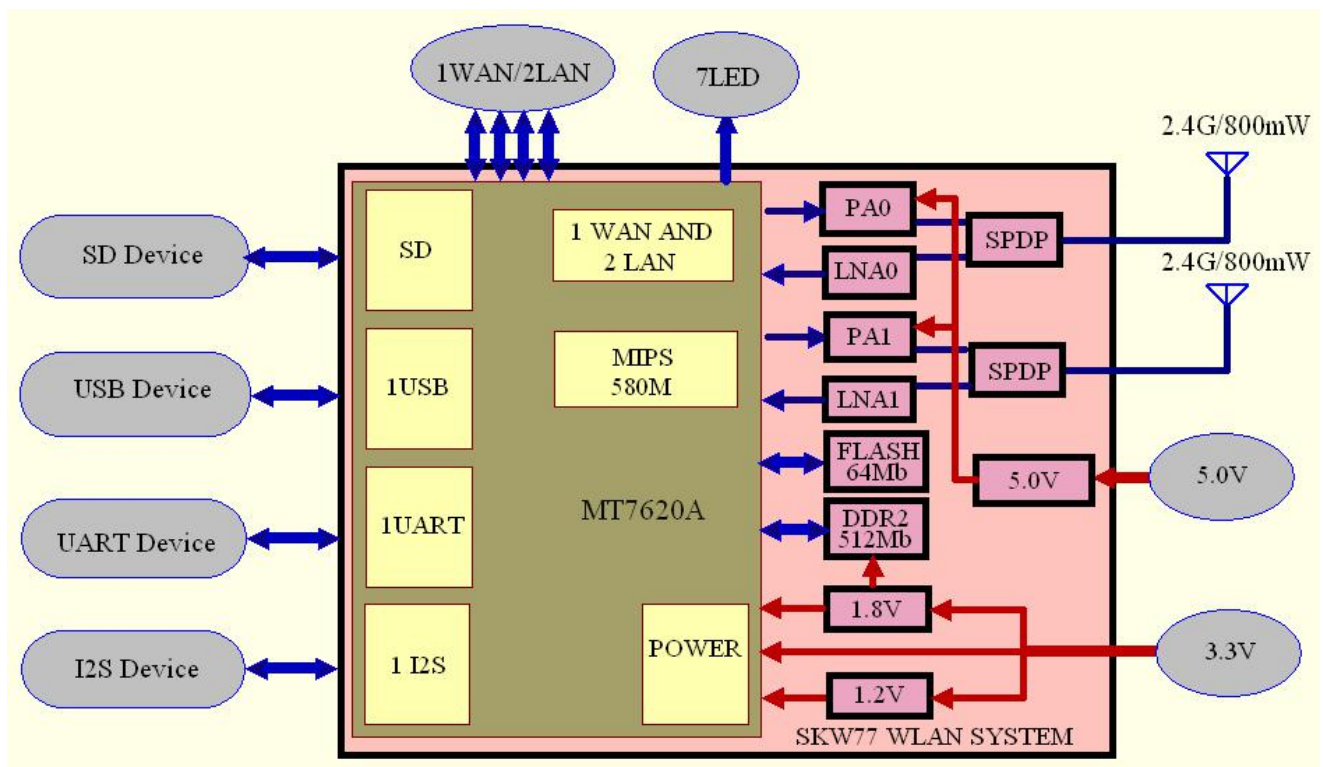

Figure 2: SKW77 Pin Package

5 Interfaces

5.1 USB

The USB interface support USB slave devices for USB disk and USB 3G/4G dongle and USB camera.

5.2 SD

Table5-1: SD pin share scheme

SKW77 Pin Number	Pin Name	GPIO(2'b1X)	SD(2'b01)
5	SD_D2	GPIO#54	SD_D2
3	SD_D3	GPIO#55	SD_D3
4	SD_CMD	GPIO#51	SD_CMD
1	SD_CLK	GPIO#49	SD_CLK
8	SD_D0	GPIO#52	SD_D0
7	SD_D1	GPIO#53	SD_D1
2	SD_CD	GPIO#50	SD_CD
6	SD_WP	GPIO#48	SD_WP

Note: Controlled by the ND_SD_GPIO_MODE register

5.3 I2S

Table5-2: I2S/PCM pin share scheme

SKW77 Pin Number	Pin Name	GPIO	I2S
36	I2S_CLK	GPIO#07	I2S_CLK
37	I2S_WS	GPIO#08	I2S_WS
35	I2S_SDO	GPIO#09	I2S_SDO
38	I2S_SDI	GPIO#10	I2S_SDI

Note: Controlled UARTF_SHARE_MODE register

Receiver

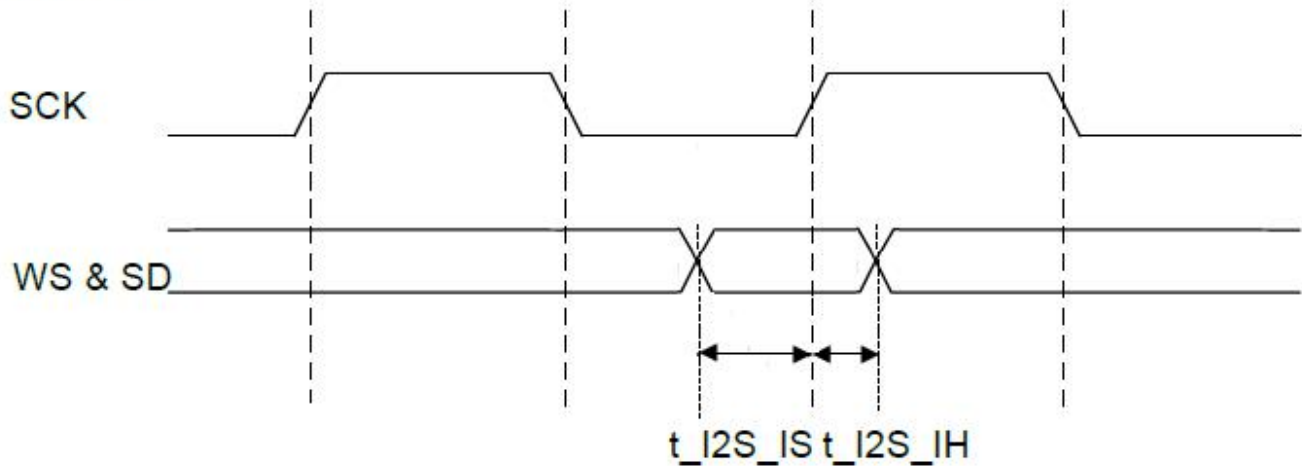

Transmitter

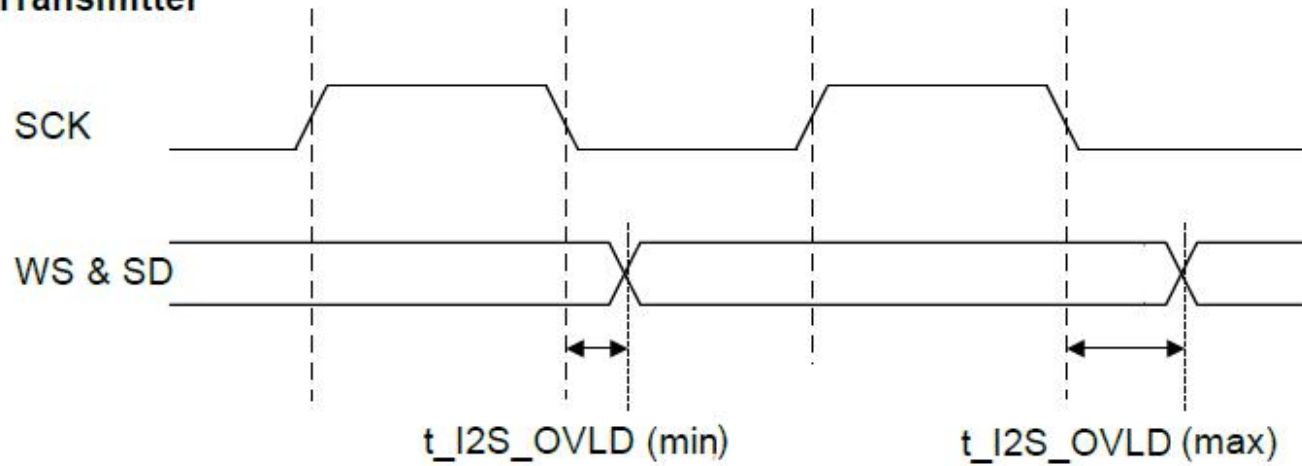

Figure 3: I2S Timing

Table5-3: I2S Interface Diagram Key

Symbol	Description	Min	Max	Unit
t_I2S_IS	Setup Time for I2S input(data & WS)	3.5		ns
t_I2S_IH	Hold Time for I2S input(data & WS)	0.5		ns
t_I2S_OVLD	I2S_CLK to I2S output(data & WS) valid	2.5	10	ns

5.4 UARTS lite

The module support 2UART:

Table5-4: UART pin share scheme

SKW77 Pin Number	Pin Name	GPIO	UART	Pin Share
31	UART_TXD0	GPIO#15	UART0_TXD	UART0(For Debug)
32	UART_RXD0	GPIO#16	UART0_RXD	
37	UART_TXD1	GPIO#8	UART1_TXD	UART1
38	UART_RXD1	GPIO#10	UART1_RXD	

5.5 WAN/LAN

The SKW77 module integrates 3-port 10/100Mbps fast Ethernet switch.

6 Module Specifications

Hardware Features	
Model	SKW77
Antenna Type	IPEX connector
Chipset solution	MT7620A
Voltage	3.0-3.6V for VDD_3.3V, 4.5-5.5V for VDD_5.0V
Dimention(L×W)	59mm*28.9mm
Wireless Features	
Wireless Standards	IEEE 802.11n, IEEE 802.11g, IEEE 802.11b
Frequency Range	2.400GHz--2.4835GHz
Data Rates	IEEE 802.11 b Standard Mode: 1,2,5.5,11Mbps
	IEEE 802.11g Standard Mode: 6,9,12,18,24,36,48,54Mbps

	IEEE 802.11n : 130Mbps @ HT20		
	300Mbps @ HT40		
Receiver Sensitivity	HT40 MCS7 : -67dBm@10% PER(MCS7)		
	HT20 MCS7 : -73dBm@10% PER(MCS7)		
	54M: -76dBm@10% PER		
	11M: -91dBm@ 8% PER		
Modulation Technique	802.11 Legacy b/g		
	DSSS (DBPSK, DQPSK, CCK)		
	OFDM (BPSK, QPSK, 16-QAM, 64-QAM)		
Wireless Security	WPA/WPA2, WEP, TKIP, and AES		
Transmit Power	IEEE 802.11n: 25dBm @HT40 MCS7		
	25dBm@HT20 MCS7		
	IEEE 802.11g: 27dBm		
	IEEE 802.11b: 29dBm		
Work Mode	Router/AP/Repeater		
Others			
Certification	CE, FCC, ROHS		
Power Consumption@25°C	Status	Average/mA	MAX/mA
	Continuous Tx @VDD_5.0	740@+27dBm	1600
	Continuous Tx @VDD_3.3V	270@+28dBm	300
	Note: 1) 5.0 V power supply is recommended to use 2A DC-DC regulator; 3.3 V power supply is recommended to use 500mA DC-DC regulator. 2) The maximum current consumption would be impacted by radiation environment and the driver mechanism		
Environment	Operating Temperature: -20°C~70°C		
	Storage Temperature: -40°C~125°C		
	Operating Humidity: 10%~90% non-condensing		
	Storage Humidity: 5%~90% non-condensing		

7 Module Pinout and Pin Description

Module Pinout:

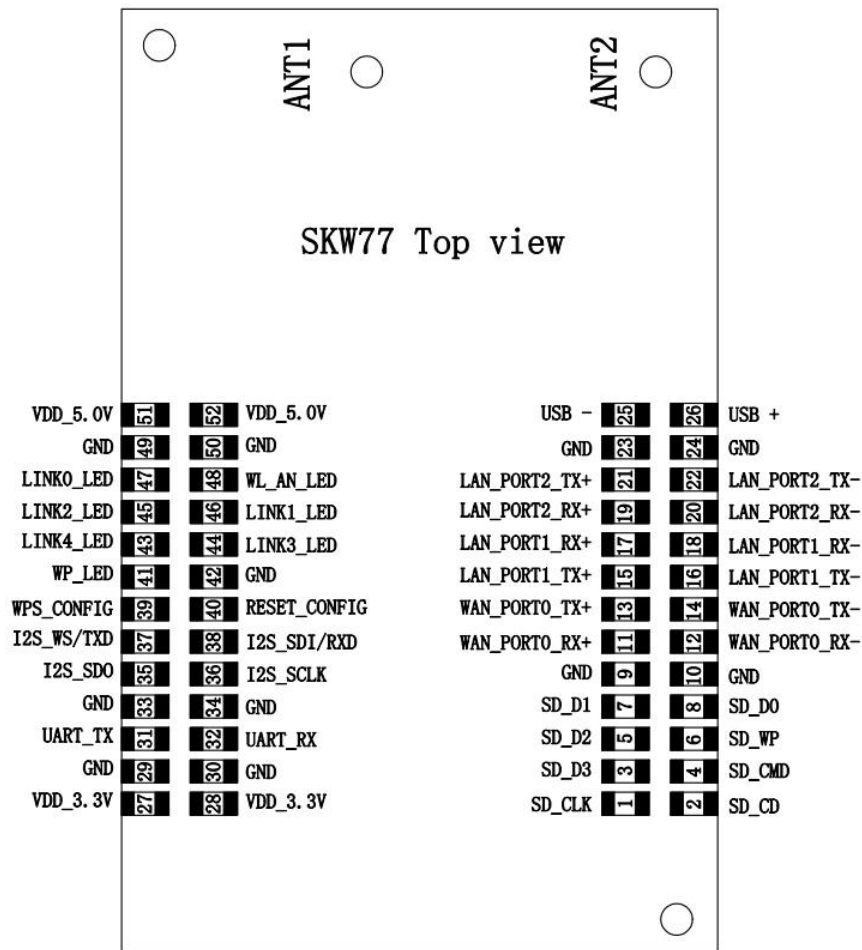

Figure 4: SKW77 Pin Package(top view)

1	SD_CLK	SD clock.
2	SD_CD	SD card detection.
3	SD_D3	SD data line3.
4	SD_CMD	SD Command line.
5	SD_D2	SD data line2.

6	SD_WP	SD write protect.
7	SD_D1	SD data line1.
8	SD_D0	SD data line0.
9	GND	GROUND
10	GND	GROUND
11	WAN_PORT0_RX+	10/100 PHY WAN port #0 RXP
12	WAN_PORT0_RX-	10/100 PHY WAN port #0 RXN
13	WAN_PORT0_TX+	10/100 PHY WAN port #0 TXP
14	WAN_PORT0_TX-	10/100 PHY WAN port #0 TXN
15	LAN_PORT1_TX+	10/100 PHY port #1 TXP
16	LAN_PORT1_TX-	10/100 PHY port #1 TXN
17	LAN_PORT1_RX+	10/100 PHY port #1 RXP
18	LAN_PORT1_RX-	10/100 PHY port #1 RXN
19	LAN_PORT2_RX+	10/100 PHY port #2 RXP
20	LAN_PORT2_RX-	10/100 PHY port #2 RXN
21	LAN_PORT2_TX+	10/100 PHY port #2 TXP
22	LAN_PORT2_TX-	10/100 PHY port #2 TXN
23	GND	GROUND
24	GND	GROUND
25	USB -	USB signal, carries USB data to and from the USB 2.0 PHY
26	USB +	USB signal, carries USB data to and from the USB 2.0 PHY
27	VDD_3.3V	3.3V input, recommended voltage 3.3V,Min3.0V, MAX 3.6V
28	VDD_3.3V	3.3V input, recommended voltage 3.3V,Min3.0V, MAX 3.6V
29	GND	GROUND
30	GND	GROUND
31	UART_TX	UART Serial Data Output, GPIO#15
32	UART_RX	UART Serial Data Input, GPIO#16
33	GND	GROUND

34	GND	GROUND
35	I2S_SDO	IIS Data Output, GPIO#9.
36	I2S_SCLK	IIS clock. In master mode the pin data direction is set output, in slave mode it is set to input, GPIO#7
37	I2S_WS/TXD	IIS Channel Selection. In master mode the pin data direction is set output, in slave mode it is set to input/ UART Serial Data Output, GPIO#8.
38	I2S_SDI/RXD	IIS Data Input/UART Serial Data Input, GPIO#10.
39	WPS_CONFIG	Module WPS Input(Active Low Status), GPIO#12.
40	RESET_CONFIG	Module Reset Input(Active Low Status), GPIO#13.
41	WP_LED	WPS LED, GPIO#39
42	GND	GROUND
43	LINK4_LED	LAN4_LED, GPIO#40
44	LINK3_LED	LAN3_LED, GPIO#44
45	LINK2_LED	LAN2_LED, GPIO#43
46	LINK1_LED	LAN1_LED, GPIO#42
47	LINK0_LED	WAN_LED, GPIO#41
48	WL_AN_LED	WLAN LED, GPIO#72
49	GND	GROUND
50	GND	GROUND
51	VDD_5.0V	5.0V input, recommended voltage 5.0V,Min4.5V, MAX 5.5V
52	VDD_5.0V	5.0V input, recommended voltage 5.0V,Min4.5V, MAX 5.5V

8 PCB Footprint and Dimensions

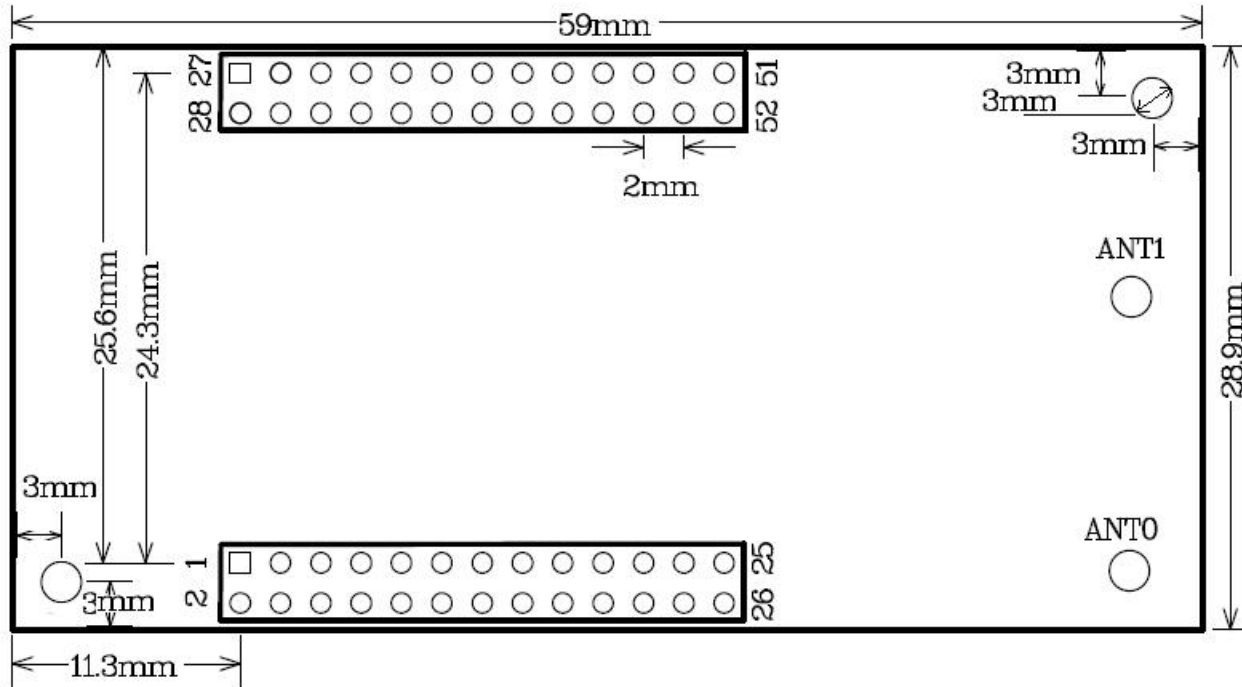

Figure 5: SKW77 Recommend PCB Footprint

9 Electrical Characteristics

a) Absolute Maximum Ratings

Table9-1: Absolute Maximum Ratings

Parameter	Condition	Min	Type	Max.	Unit
Storage temperature range		-40		125	°C
ESD Protection	VESD	/		2000	V
Supply voltage	VDD_3.3V	0		3.6	V
Supply voltage	VDD_5.0V	0		5.5	V
Voltage on any I/O pin		-0.3		3.63	V

b) Recommended Operation Ratings

Table9-2: Operating Conditions

Parameter	Symbol	Minimum	Typical	Maximum	Unit
Extended temp. range	TA	-20		55	°C
Power Supply	VDD_3.3V	3.0	3.3	3.6	V
Power Supply	VDD_3.3V	4.5	5.0	5.5	V
Input Low Voltage	VIL	-0.3		0.8	V
Input High Voltage	VIH	2		3.63	V

c) Measurement Conditions

Table9-3: Power Consumption in Different States

System state	Current (Type)@3.3V
Standby	180mA
Transmit (2.4g; +27dBm @ 11g 54Mbps)	740mA
Transmit (2.4g; +29dBm @ 11b 11Mbps.)	1560mA

10 Ordering Information

Module No.	Antenna Connector Type	SPI Flash Size
SKW77_E8	IPEX Connector	8M Bytes
SKW77_E16	IPEX Connector	16M Bytes

11 Contact Information

Skylab M&C Technology Co., Ltd.

深圳市天工测控技术有限公司

Address: 6 Floor, No.9 Building, Lijincheng Scientific & Technical park, Gongye East Road,

Longhua District, Shenzhen, Guangdong, China

Phone: 86-755 8340 8210 (Sales Support)

Phone: 86-755 8340 8510 (Technical Support)

Fax: 86-755-8340 8560

E-Mail: sales1@skylab.com.cn

Website: www.skylab.com.cn www.skylabmodule.com