

# SKW72 AP/Repeater/UART WiFi Module Datasheet

Name: 802.11b/g/n AP/Repeater & UART WIFI Module

Model No.: SKW72

Revision: V2.05

## Revision History

Revision	Description	Approved	Date
V1.01	Initial Release	George	20131121
V2.01	Update Office Address	George	20150721
V2.02	Add Ordering Information	George	20150723
V2.03	Update Ordering Information	George	20160312
V2.04	Update photo Information	George	20161023
V2.05	Update certification information	George	20170831

## Contents

SKW72 AP/Repeater/UART .....	1
WiFi Module.....	1
Datasheet .....	1
1. General Description .....	3
2. Applications .....	3
3. Features.....	3
4. Application Block Diagram .....	4
5. Interfaces .....	4
USB .....	4
UART .....	4
GPIO.....	5
WAN/LAN .....	5
6. Module Specifications .....	5
7. Module Pinout and Pin Description .....	7
Module Pinout .....	7
Pin Description .....	7
8. PCB Footprint and Dimensions.....	10
9. Electrical Characteristics .....	10
10. Manufacturing Process Recommendations .....	11
11. Ordering Information.....	12
12. Contact Information .....	12

## 1. General Description

The SKW72 module integrates a 1T1R 802.11n Wi-Fi radio, a MIPS 24K processor, 2-port fast Ethernet PHY, USB2.0 host, I2S and multiple slow IOs. Solution for low power, low-cost, and highly integrated AP router and consumer electronic devices, the module requires only an external 3.3V power supply. It supports 802.11n operating up to 72.2 Mbps for 20 MHz and 150 Mbps for 40 MHz channel respectively, and IEEE 802.11b/g data rates.

The module supports AP mode and client mode and repeater mode and UART WiFi. The high performance module can process advanced applications effortlessly, such as routing, security and VoIP.

## 2. Applications

- ◆ AP WiFi
- ◆ UART WiFi
- ◆ Repeater WiFi
- ◆ IP TV
- ◆ IP DVD(Internet VOD Player)
- ◆ Building Automation
- ◆ Home Automation
- ◆ Gaming Consoles
- ◆ DVR

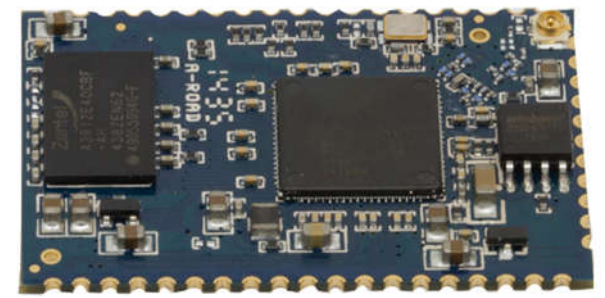

Figure 1: SKW72 Top View

## 3. Features

- ◆ Compliant to IEEE 802.11b/g/n 1x1 WLANs
- ◆ DDR2 memory up to 512Mb
- ◆ Flash memory up to 64Mb
- ◆ 4LAN ports and 1 WAN port
- ◆ High-speed UART
- ◆ USB 2.0 host device mode support
- ◆ Support AP/Client/Repeater mode
- ◆ Support UART to WiFi transparent
- ◆ Security: WEP 64/128, WPA, WPA2, TKIP, AES, WAPI
- ◆ RoHS compliance meets environment-friendly requirement
- ◆ FCC, CE certificated
- ◆ 40.5(L) x 27.5(W) x 2.9(H) mm small dimension

## 4. Application Block Diagram

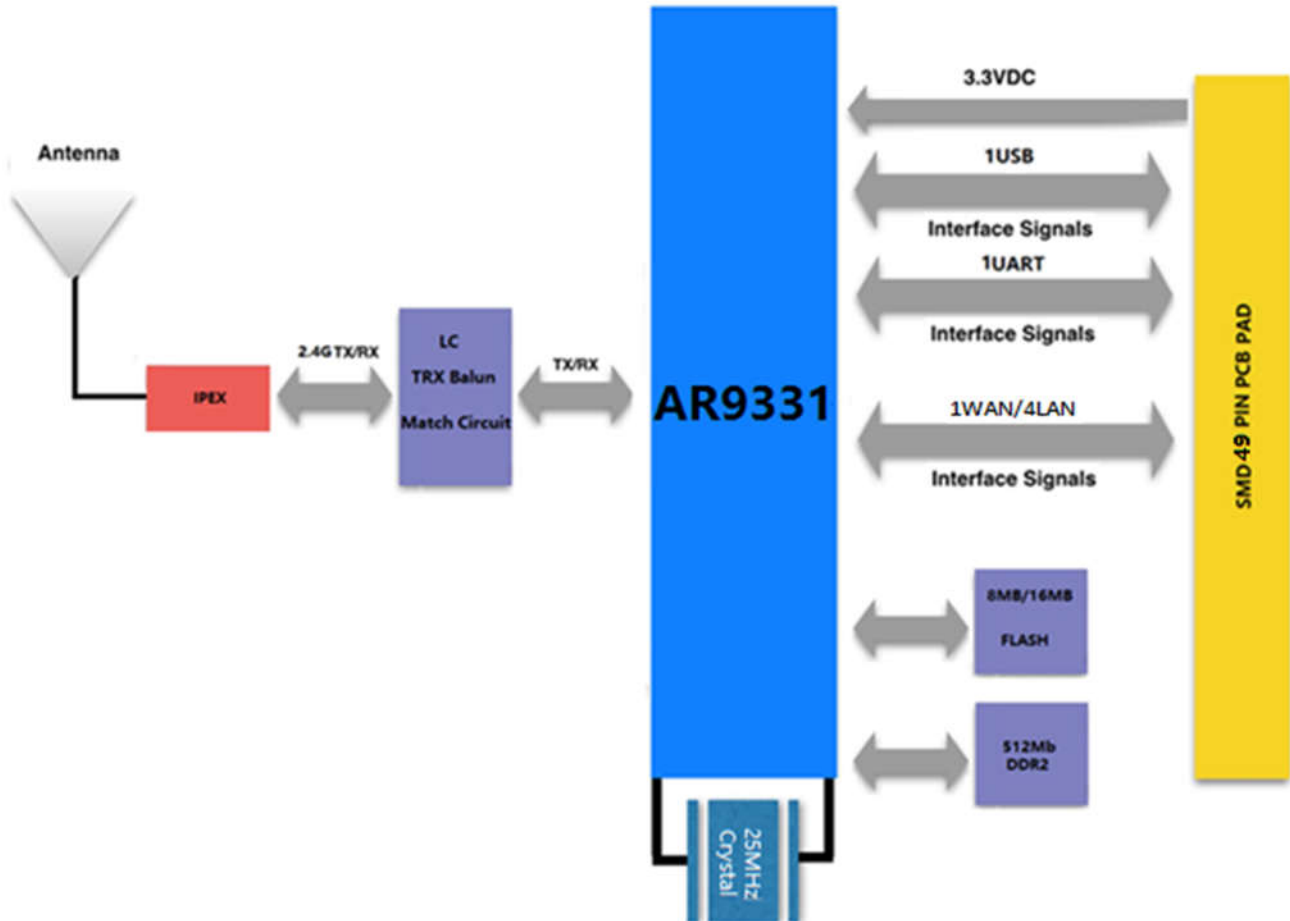

Figure 2: SKW72 Block Diagram

## 5. Interfaces

### USB

The USB interface support USB slave devices for USB disk and USB 3G/4G dongle and USB camera.

### UART

The UART default baud rate is 115200bps.

## GPIO

SKW72 Pin Number	GPIO	Description	Share function
7	GPIO12	RESET_CONFIG	
48	GPIO11	JUMPSTART	
8	GPIO17	LED6/WAN LED	LED
9	GPIO16	LED5/LAN3 LED	
10	GPIO15	LED4/LAN2 LED	
11	GPIO14	LED3/LAN1 LED	
12	GPIO27	LED7/SYSTEM LED	
13	GPIO1	LED1/USB LED	
14	GPIO13	LED2/LAN0_LED	
15	GPIO0	LED0/Wireless LED	
47	GPIO26	JMP_START LED	

## WAN/LAN

The SKW72 module integrates 5-port 10/100Mbps fast Ethernet switch.

## 6. Module Specifications

Hardware Features	
Model	SKW72
Antenna Type	IPEX connector or PCB antenna
Chipset solution	AR9331
Voltage	3.30V+/-10%
Dimensions(W×D)	40.5mm*27.5mm
Wireless Features	
Wireless Standards	IEEE 802.11n, IEEE 802.11g, IEEE 802.11b
Frequency Range	2.400GHz---2.4835GHz
Data Rates	IEEE 802.11 b Standard Mode: 1,2,5.5,11Mbps
	IEEE 802.11g Standard Mode: 6,9,12,18,24,36,48,54Mbps

	IEEE 802.11n : 65Mbps @ HT20
	150Mbps @ HT40
<b>Receiver Sensitivity</b>	135M: -65dBm@10% PER(MCS7)
	72.2M: -70dBm@10% PER(MCS7)
	54M: -75dBm@10% PER
	11M: -86dBm@ 8% PER
<b>Modulation Technique</b>	802.11 Legacy b/g
	DSSS (DBPSK, DQPSK, CCK)
	OFDM (BPSK, QPSK, 16-QAM, 64-QAM)
<b>Wireless Security</b>	WPA/WPA2, WEP, TKIP, and AES
<b>Transmit Power</b>	IEEE 802.11n: 14dBm @HT40 MCS7
	IEEE 802.11b: 18dBm
<b>Work Mode</b>	Ad-Hoc / Infrastructure mode/AP/Repeater/UART
<b>Others</b>	
<b>Certification</b>	CE, FCC, RoHS
<b>Environment</b>	Operating Temperature:-20°C~70°C
	Storage Temperature: -65°C~150°C
	Operating Humidity: 10%~90% non-condensing
	Storage Humidity: 5%~90% non-condensing

## 7. Module Pinout and Pin Description

### Module Pinout:

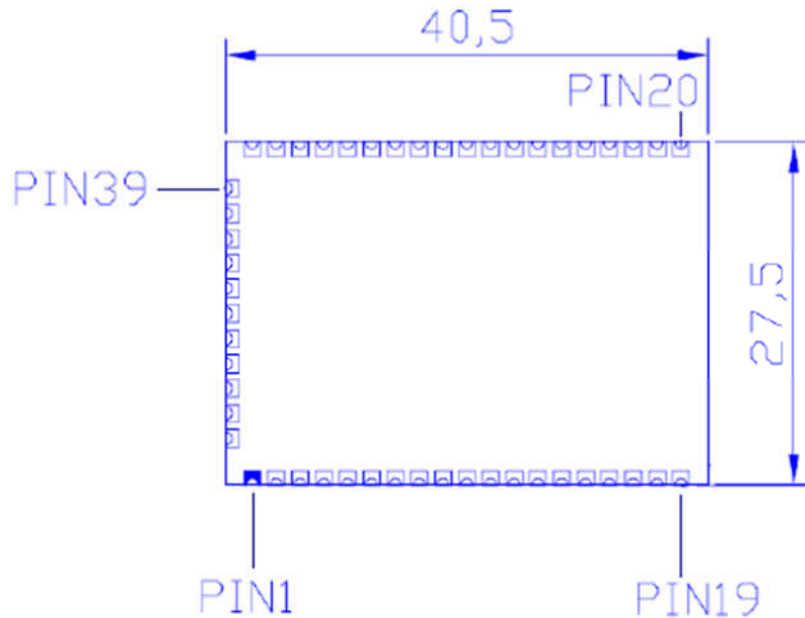

Figure 3: SKW72 Pin Package

### Pin Description:

Pin No.	Pin name	Description
1	GND	GROUND
2	ANT	Antenna pin
3	GND	GROUND
4	NC	NC
5	NC	NC
6	NC	NC
7	RESET_CONFIG (UART_CTS) (GPIO_12)	resets the firmware to its default configuration. Active pulling up.
8	LED6 (GPIO_17)	WLAN LED
9	LED5 (GPIO_16)	LAN_PORT3_LED, be free for customer defined.
10	LED4 (GPIO_15)	LAN_PORT2_LED

11	LED3 (GPIO_14)	LAN_PORT1_LED
12	LED7(GPIO_27)	SYSTEM LED
13	LED1 (GPIO_1)	USB LED
14	LED2 (GPIO_13)	LAN_PORT0_LED
15	LED0 (GPIO_0)	Wireless LED
16	UART_RX (SPI_CS1)	Serial data in
17	UART_TX (SPI_CS2)	Serial data out
18	GND	GROUND
19	GND	GROUND
20	WAN_PORT_RX+	WAN port
21	WAN_PORT_RX-	WAN port
22	WAN_PORT_TX+	WAN port
23	WAN_PORT_TX-	WAN port
24	LAN_PORT3_TX+	Ethernet port3
25	LAN_PORT3_TX-	Ethernet port3
26	LAN_PORT3_RX+	Ethernet port3
27	LAN_PORT3_RX-	Ethernet port3
28	LAN_PORT2_RX+	Ethernet port2
29	LAN_PORT2_RX-	Ethernet port2
30	LAN_PORT2_TX+	Ethernet port2
31	LAN_PORT2_TX-	Ethernet port2
32	LAN_PORT1_TX+	Ethernet port1
33	LAN_PORT1_TX-	Ethernet port1
34	LAN_PORT1_RX+	Ethernet port1
35	LAN_PORT1_RX-	Ethernet port1
36	GND	GROUND
37	VDD_3.3V	3.3V input 1000mA, recommended voltage 3.3V, Min2.97V, MAX 3.63V



38	VDD_3.3V	3.3V input 1000mA, recommended voltage 3.3V,Min2.97V, MAX 3.63V
39	VDD_2.0V OUTPUT	Power supply output for peripheral network transformer
40	GND	GROUND
41	LAN_PORT0_RX+	Ethernet port0
42	LAN_PORT0_RX-	Ethernet port0
43	LAN_PORT0_TX+	Ethernet port0
44	LAN_PORT0_TX-	Ethernet port0
45	USB -	USB signal, carries USB data to and from the USB 2.0 PHY
46	USB +	USB signal, carries USB data to and from the USB 2.0 PHY
47	LED8(GPIO_26)	JMP_START LED
48	JUMPSTART (UART_RTS) (GPIO_11)	KEY_INPUT to start WPS function. Active pulling up.
49	GND	GROUND

## 8. PCB Footprint and Dimensions

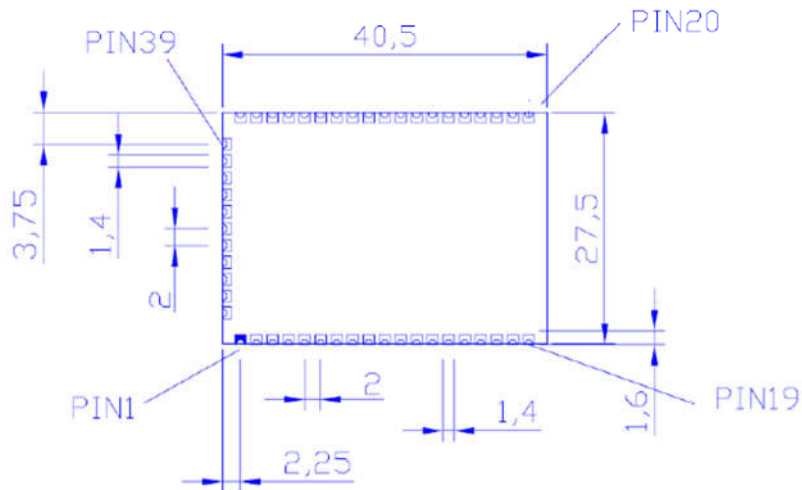

Figure 4: SKW72 Footprint

## 9. Electrical Characteristics

### a) Absolute Maximum Ratings

Parameter	Condition	Min	Typ.	Max.	Unit
Storage temperature range		-65		150	°C
ESD Protection	VESD	/		2000	V
Supply voltage	VDD_3.3V	0		4.0	V
Voltage on any I/O pin		-0.3		4.0	V

Table9-1: Absolute Maximum Ratings

### b) Recommended Operation Ratings

Parameter	Symbol	Minimum	Typical	Maximum	Unit
Extended temp.	TA	-20		70	°C

Power Supply	VDD_3.3V	2.97	3.3	3.63	V
Input Low Voltage	VIL	-0.3		0.8	V
Input High Voltage	VIH	2		3.63	V

Table9-2: Operating Conditions

c) Measurement Conditions

System state	Current (Typ.)@3.3V
Standby	70 mA
Transmit (2.4g; +15 dBm @ TX HT20 MCS7.)	310 mA
Transmit (2.4g; +18 dBm @ 11b 11Mbps.)	350 mA

Table9-3: Power Consumption in Different States

10. Manufacturing Process Recommendations

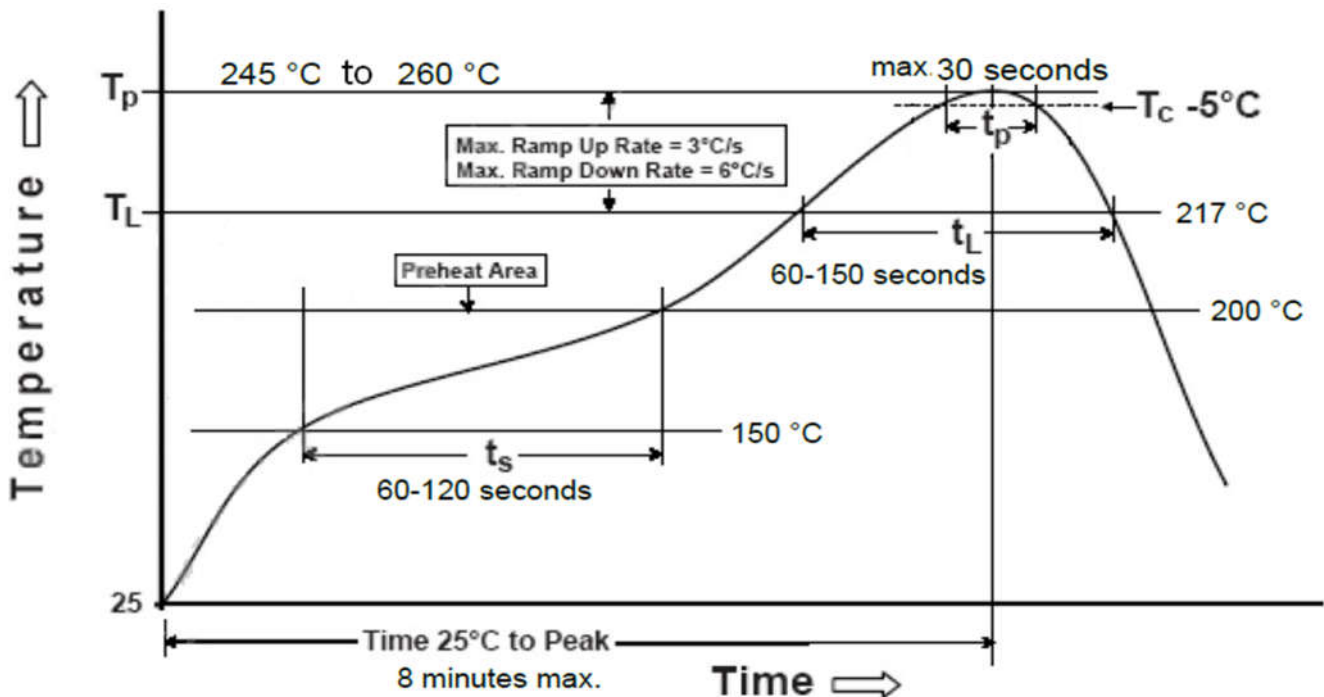

Figure 5: SKW72 Typical Lead-free Soldering Profile

**Note :** The final soldering temperature chosen at the factory depends on additional external factors like choice of soldering paste , size , thickness and properties of the baseboard , etc. Exceeding the maximum soldering temperature in the recommended soldering profile may permanently damage the module.

## 11. Ordering Information

Module No.	Antenna Connector Type	SPI Flash Size
SKW72_E8	IPEX Connector	8M Byte
SKW72_E16	IPEX Connector	16M Byte
SKW72_P8	PCB Antenna	8M Byte
SKW72_P16	PCB Antenna	16M Byte

## 12. Contact Information

Skylab M&C Technology Co., Ltd.

深圳市天工测控技术有限公司

**Address:** 6 Floor, No.9 Building, Lijincheng Scientific & Technical park, Gongye East Road,  
Longhua District, Shenzhen, Guangdong, China

**Phone:** 86-755 8340 8210 ( Sales Support )

**Phone:** 86-755 8340 8510 ( Technical Support )

**Fax:** 86-755-8340 8560

**E-Mail:** sales1@skylab.com.cn

**Website:** www.skylab.com.cn      www.skylabmodule.com