

# SKG12D Datasheet

## GNSS Module

**Document Information**

<b>Title</b>	SKG12D High-performance GPS/Glonass/BDS/ GALILEO Solution Module Datasheet	
<b>Document type</b>	Datasheet	
<b>Document number</b>	SL-18110094	
<b>Revision and date</b>	V4.05	20-Apr.-2021
<b>Disclosure restriction</b>	Public	

## Revision History:

Revision	Description	Approved	Date
V1.01	Initial Release to V1.01	George	20120608
V2.01	Update office's address	George	20131119
V3.02	Update FW	Woody	20150312
V3.03	Update Top View Photo	George	20170531
V3.04	Update certification information	George	20170831
V3.05	Add Galileo information	George	20171113
V4.01	Update: Dimensions and Fully enclosed shield cover and QR code labeling	George	20181126
V4.02	Add specification of Coplanarity	Benson	20190305
V4.03	Delete specification of Coplanarity and Add stencil thicknesses	George	20190703
V4.04	Update Power Supply	George	20200803
V4.05	Update format	Wendy	20210420

SKYLAB reserves all rights to this document and the information contained herein. Products, names, logos and designs described herein may in whole or in part be subject to intellectual property rights. Reproduction, use, modification or disclosure to third parties of this document or any part thereof without the express permission of SKYLAB is strictly prohibited.

The information contained herein is provided "as is" and SKYLAB assumes no liability for the use of the information. No warranty, either express or implied, is given, including but not limited, with respect to the accuracy, correctness, reliability and fitness for a particular purpose of the information. This document may be revised by SKYLAB at any time. For most recent documents, visit [www.skylab.com.cn](http://www.skylab.com.cn).

Copyright © 2012, Skylab M&C Technology Co., Ltd.

SKYLAB® is a registered trademark of Skylab M&C Technology Co., Ltd in China.

## Contents

2.Applications.....	5
3.Features.....	6
4.Pin Assignment.....	6
5.Pin Description.....	7
6.Interfaces Configuration.....	7
Power Supply.....	7
Backup Battery Power.....	8
Antenna.....	8
VCC_out.....	8
UART Ports.....	9
EXTINT1.....	9
RF_IN.....	9
PPS.....	9
FIXLED.....	9
7.Advanced Software Features.....	10
Standby Mode.....	10
Periodic Mode.....	10
Always Locate™.....	10
AGPS Support for Fast TTFF (EPO™).....	10
EASY™.....	11
Embedded Logger function.....	11
AIC_Multi-tone active interference canceller.....	11
GNSS.....	11
8.Performance Specification.....	12
9.Electrical Characteristics.....	12

Absolute Maximum Rating.....	12
Operating Conditions.....	13
10.Mechanical Specification.....	14
11.Reference design schematic.....	16
12.Packaging Specification.....	16
13.Manufacturing Process Recommendations.....	17
14.Software Protocol.....	18
NMEA 0183 Protocol.....	18
GGA-Global Positioning System Fixed Data.....	18
GLL-Geographic Position – Latitude/Longitude.....	20
GSA-GNSS DOP and Active Satellites.....	20
GSV-GNSS Satellites in View.....	22
RMC-Recommended Minimum Specific GNSS Data.....	23
VTG-Course Over Ground and Ground Speed.....	24
ZDA-Date and Time.....	24
CMD List.....	25
15 Contact Information.....	26

## 1. General Description

The SKG12D is a high-performance GNSS all-in-one solution module that features super sensitivity, ultra low power and small form factor. The RF signal is applied to the antenna input of module, and a complete serial data message with position, velocity and time information is presented at the serial interface with NMEA protocol or custom protocol.

It is based on the high performance features of the MediaTek MT3333 single-chip architecture, Its  $-165\text{dBm}$  tracking sensitivity extends positioning coverage into place like urban canyons and dense foliage environment where the GNSS was not possible before. The small form factor and low power consumption make the module easy to integrate into portable device like PNDs, mobile phones, cameras and vehicle navigation systems.



Figure 1: SKG12D Top View

## 2. Applications

- LBS (Location Based Service)
- PND (Portable Navigation Device)
- Vehicle navigation system
- Mobile phone

### 3.Features

- GPS/GLONASS/BDS/ GALILEO/QZSS reseiver
- Ultra high sensitivity: -165dBm
- Extremely fast TTFF at low signal level
- Built-in 12 multi-tone active interference canceller
- Ultra low power consumption
- $\pm 20$ ns high accuracy time pulse (1PPS)
- Advanced Features: Always Locate; AIC; EPO;EASY
- SBAS (WAAS,EGNOS,MSAS,GAGAN)
- Indoor and outdoor multi-path detection and compensation
- Small form factor: 16.2 x 12.2 x 2.4mm
- FCC compliance
- ROHS compliance (Lead-free)
- CE certificated

### 4.Pin Assignment

1	FIXLED	GND	24
2	GPIO11	VCC	23
3	PPS	V_BCKP	22
4	EXTINT1	RXD0	21
5	NC	TXD0	20
6	NC	RXD1	19
7	NC	TXD1	18
SKG12D Top view			
8	V_ANT	NC	17
9	VCC_OUT	NC	16
10	GND	GPIO15	15
11	RF_IN	GPIO14	14
12	GND	GND	13

Figure 2: SKG12D Pin Package

## 5.Pin Description

Pin No.	Pin name	I/O	Description	Remark
1	FIXLED	O	Fixed LED Output	Default off .Leave open if not used
2	GPIO11	I/O	General Purpose I/O	Leave open if not used
3	PPS	O	Time Pulse Signal (Default 100ms)	Leave open if not used
4	EXTINT1	I	External Interrupt	Leave open if not used
5	NC			
6	NC			
7	NC			
8	V_ANT	I	Active Antenna External Voltage Supply	Leave open if not used
9	VCC_OUT	O	VCC power output	Leave open if not used
10	GND	G	Ground	
11	RF_IN	I	RF Signal Input	50Ω
12	GND	G	Ground	
13	GND	G	Ground	
14	GPIO14	I/O	General Purpose I/O	Leave open if not used
15	GPIO15	I/O	General Purpose I/O	Leave open if not used
16	NC			
17	NC			
18	TXD1	O	UART Serial Data Output 1	Leave open if not used
19	RXD1	I	UART Serial Data Input 1	Leave open if not used
20	TXD0	O	UART Serial Data Output 0	Leave open if not used
21	RXD0	I	UART Serial Data Input 0	Leave open if not used
22	V_BCKP	I	RTC and backup SRAM power	This pin may be connect to Battery or Power Supply(2.0~4.2V)
23	VCC	P	Module Power Supply	Operating range: 3.0V to 4.2V
24	GND	G	Ground	

## 6.Interfaces Configuration

### Power Supply

Regulated power for the SKG12D is required. The input voltage VCC should be 3.0V to 4.2V range, current is no less than 100mA. Suitable decoupling must be provided by external decoupling circuitry (10uF and 0.1uF). It can reduce the Noise from power supply and increase power stability.

Main power supply VCC current varies according to the processor load and satellite acquisition. Maximum VCC peak current is about 45 mA during acquisition.

The power LDO is important to supply sufficient current and make the power clean and stable. VCC supply ripple voltage should meet the requirement: 54mV (RMS) max @f=0... 3MHz and 15mV (RMS) max@f> 3MHz. You should choose the LDO without built-in output high-speed discharge function to keep long output voltage drop-down period.

## Backup Battery Power

In case of a power failure on pin VCC, real-time clock and backup RAM are supplied through pin V\_BCKP. This enables the SKG12D Receiver to recover from power failure with either a hot start or a warm start (depending on the duration of VCC outage). If no Backup Battery is connected, the receiver performs a cold start upon powered up.

Backup Battery Power V\_BCKP draws typically 15 uA current in backup state.

## Antenna

The SKG12D receiver is designed for supporting the active antenna or passive antenna connected with pin RF\_IN. The gain of active antenna should be no more than 25dB (18~20dB Typical). The maximum noise figure should be no more than 1.5dB and output impedance is at 50 Ohm.

### NOTE

With passive antenna keep the cable loss at minimum(<1dB).
--

## VCC\_out

Antenna power output pin. When user wants to use external active antenna. The pin supply power for active antenna.



## UART Ports

The module supports one full duplex serial channels UART. The serial connections are at 2.85V LVTTTL logic levels, if need different voltage levels, use appropriate level shifters. the data format is however fixed: X, N, 8, 1, i.e. X baud rate, no parity, eight data bits and one stop bit, no other data formats are supported, LSB is sent first. The modules default baud rate is set up 9600bps. The RXD0 & TXD0 recommended to pull up (10K $\Omega$ ). It can increase the stability of serial data.

## EXTINT1

The default EXTINT1 function is Standby mode control but the function is not supported; leave signal floating (not connected).

## RF\_IN

The transmission line must to be control impedance from RF\_IN pin to the antenna or antenna connector of your choice. (Impedance 50 $\Omega$ )

## PPS

A pulse per second (1 PPS) is an electrical signal that very precisely indicates the start of a second. Depending on the source, properly operating PPS signals have an accuracy ranging 10ns. The PPS signals are used for precise timekeeping and time measurement.

## FIXLED

The default FIXLED function is valid fix indicator output. Without a valid fix the signal is at low state; during valid fix condition the signal outputs 50ms pulses every seconds.

## 7. Advanced Software Features

### Standby Mode

User can issue software command to make GNSS module go into standby mode that consumes less than 200uA current. GNSS module will be awaked when receiving any byte. The following flow chart is an example to make GNSS module go into standby mode and then wake up.

### Periodic Mode

When GNSS module is commanded to periodic mode, it will be in operation and standby periodically. Its status of power consumption is as below chart

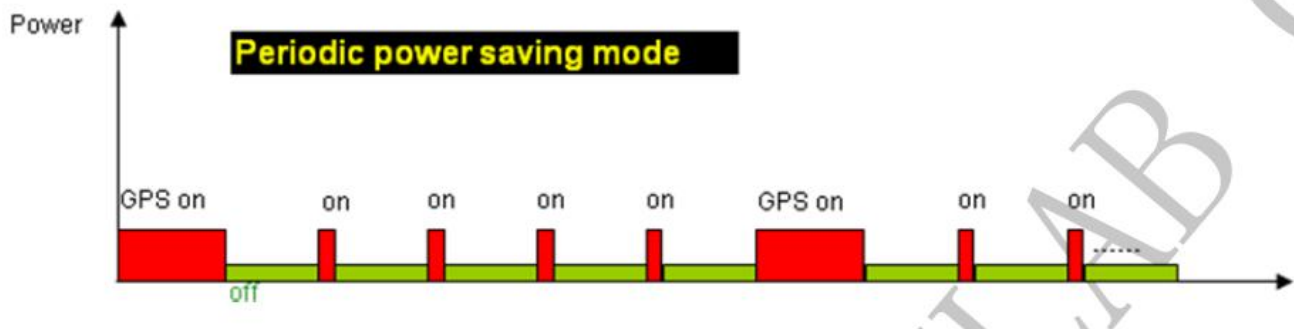

### Always Locate™

Always Locate™ is an intelligent controller of periodic mode. Depending on the environment and motion conditions, GNSS module can adaptively adjust working/standby time to achieve balance of positioning accuracy and power consumption. In this mode, the host CPU does not need to control GNSS module until the host CPU needs the GPS position data. The following flow chart is an example to make GNSS module go into Always Locate™ mode and then back to normal operation mode.

### AGPS Support for Fast TTFF (EPO™)

The AGPS (EPO™) supply the predicated Extended Prediction Orbit data to speed TTFF ,users can download the EPO data to GPS engine from the FTP server by internet or wireless network ,the GPS engine

will use the EPO data to assist position calculation when the navigation information of satellites are not enough or weak signal zone .

## **EASY™**

The EASY™ is embedded assist system for quick positioning, the GPS engine will calculate and predict automatically the single emperies ( Max. up to 3 days )when power on ,and save the predict information into the memory , GPS engine will use these information for positioning if no enough information from satellites , so the function will be helpful for positioning and TTFF improvement under indoor or urban condition ,the Backup power (VBACKUP) is necessary .

## **Embedded Logger function**

The Embedded Logger function don't need host CPU (MCU ) and external flash to handle the operation , GPS Engine will use internal flash (embedded in GPS chipset ) to log the GPS data (Data format : UTC, Latitude , longitude, Valid ,Checksum ), the max log days can up to 2 days under AlwaysLocate™ condition .

## **AIC\_Multi-tone active interference canceller**

Because different application (Wi-Fi , GSM/GPRS,3G/4G,Bluetooth )are integrated into navigation system , the harmonic of RF signal will influence the GPS reception , The multi- tone active-interference canceller can reject external RF interference which come from other active components on the main board , to improve the capacity of GPS reception without any needed HW change in the design .SKG12D can cancel up to 12 independent channel interference continuous wave.

## **GNSS**

The SKG12D GNSS modules can receive and track multiple GNSS systems (e.g. GPS, GLONASS and BeiDou signals). The SKG12D can be configure to start searching of which satellite system. By default the receivers are configured for concurrent GPS and GLONASS reception.

## 8. Performance Specification

Parameter	Specification	
Receiver Type	GPS, GLONASS, BDS, GALILEO, QZSS	
Sensitivity	Tracking	-165dBm Typical
	Acquisition	-148dBm Typical
Accuracy	Position	<2.5m CEP50 (Typical Open Sky)
	Velocity	0.1m/s without SA
	Timing (PPS)	20ns RMS
Acquisition Time	Cold Start	23s(Typical Open Sky)
	Warm Start	2-3s
	Hot Start	1s
	Re-Acquisition	<1s
Assisted GPS support	EPO	
Power Consumption	Tracking	35mA @3.3V Typical
	Acquisition	40mA @3.3V
Navigation Data Update Rate	Max 10Hz	Default 1Hz
Operational Limits	Altitude	Max 18,000m
	Velocity	Max 515m/s
	Acceleration	Less than 4g

## 9. Electrical Characteristics

### Absolute Maximum Rating

Parameter	Symbol	Min	Max	Units
<b>Power Supply</b>				
Power Supply Volt.	VCC	-0.3	4.3	V
<b>Input Pins</b>				

Input voltage on any input connection	V <sub>IO</sub>	-0.3	3.6	V
Backup Battery	V <sub>BCKP</sub>	-0.3	4.3	V
RF input power	RF_IN		-40	dBm
Human Body Model ESD capability	RF_IN		2000	V
Machine Model ESD capability	RF_IN		100	V
<b>Environment</b>				
Storage Temperature	T <sub>stg</sub>	-40	125	°C
Peak Reflow Soldering Temperature <10s	T <sub>peak</sub>		260	°C
Humidity			95	%

**Note:** Absolute maximum ratings are stress ratings only, and functional operation at the maxims is not guaranteed. Stress beyond the limits specified in this table may affect device reliability or cause permanent damage to the device. For functional operating conditions, refer to the operating conditions tables as follow.

## Operating Conditions

Parameter	Symbol	Condition	Min	Typ	Max	Units
Power supply voltage	VCC		3	3.3	4.2	V
Backup Battery	V <sub>BCKP</sub>		2	3.3	4.2	V
Power supply voltage ripple	VCC_PP	VCC=3.3V			30	mV
Supply current, Acquisition	ICC	VCC=3.3V		40		mA
Supply current, Tracking	ICC	VCC=3.3V		35		mA
Supply current, backup state	I <sub>bckp</sub>	VCC=3.3V		15		uA
VCC_OUT Antenna bias supply	VCC_OUT			VCC		V
Input high voltage	V <sub>IH</sub>		2		3.6	V
Input low voltage	V <sub>IL</sub>		-0.3		0.8	V

Output high voltage	V <sub>OH</sub>		2.4		3.1	V
Output low voltage	V <sub>OL</sub>		-0.3		0.4	V
Operating temperature	T <sub>opr</sub>		-40		85	°C

## 10.Mechanical Specification

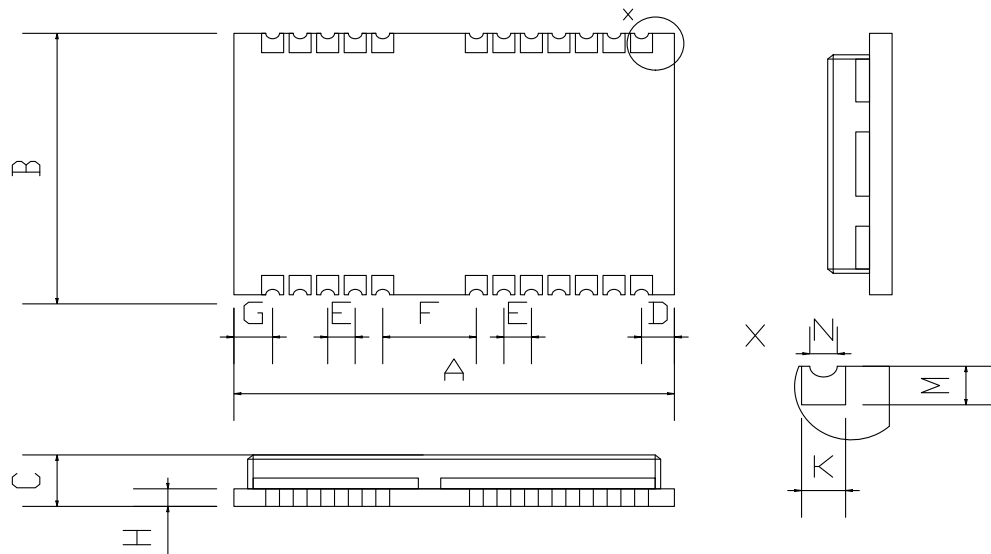

Parameter	specification	Units
Coplanarity	≤0.1	mm

Symbol	Min.(mm)	Typ.(mm)	Max.(mm)
A	16.0	16.3	16.6
B	12.0	12.2	12.4
C	2.2	2.4	2.6
D	0.9	1.0	1.3
E	1.0	1.1	1.2
F	2.9	3.0	3.1
G	0.9	1.0	1.3
H		0.8	
M	0.8	0.9	1.0
N	0.4	0.5	0.6
K	0.7	0.8	0.9
Weight		1.6g	

Figure 3: SKG12D Dimensions

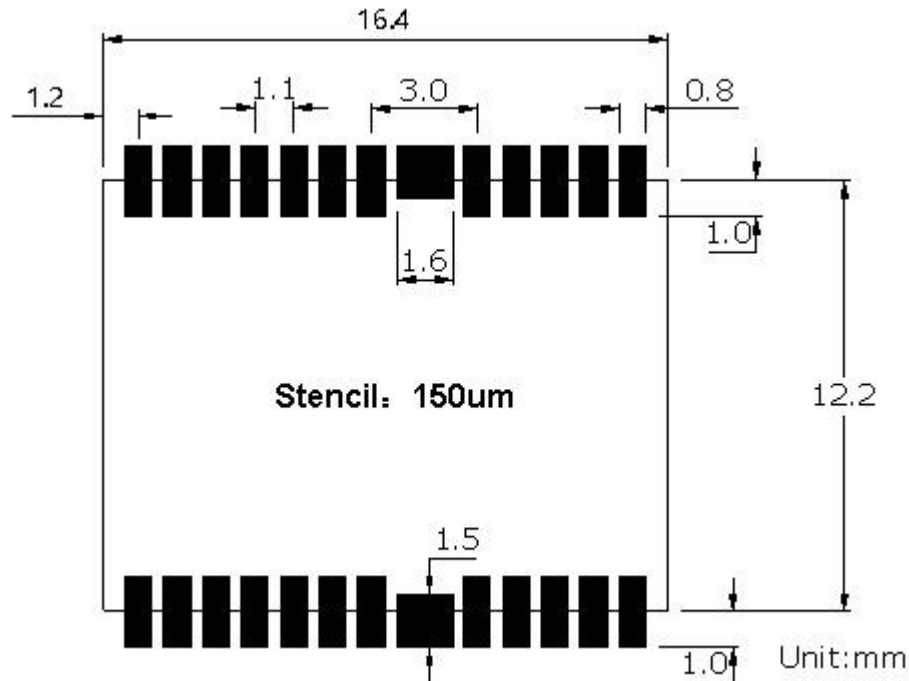
**Recommend Layout****Figure 4: SKG12D Footprint**

Consider the paste mask outline when defining the minimal distance to the next component. The exact geometry, distances, stencil thicknesses and solder paste volumes must be adapted to the specific production processes (e.g. soldering) of the customer.

## 11.Reference design schematic

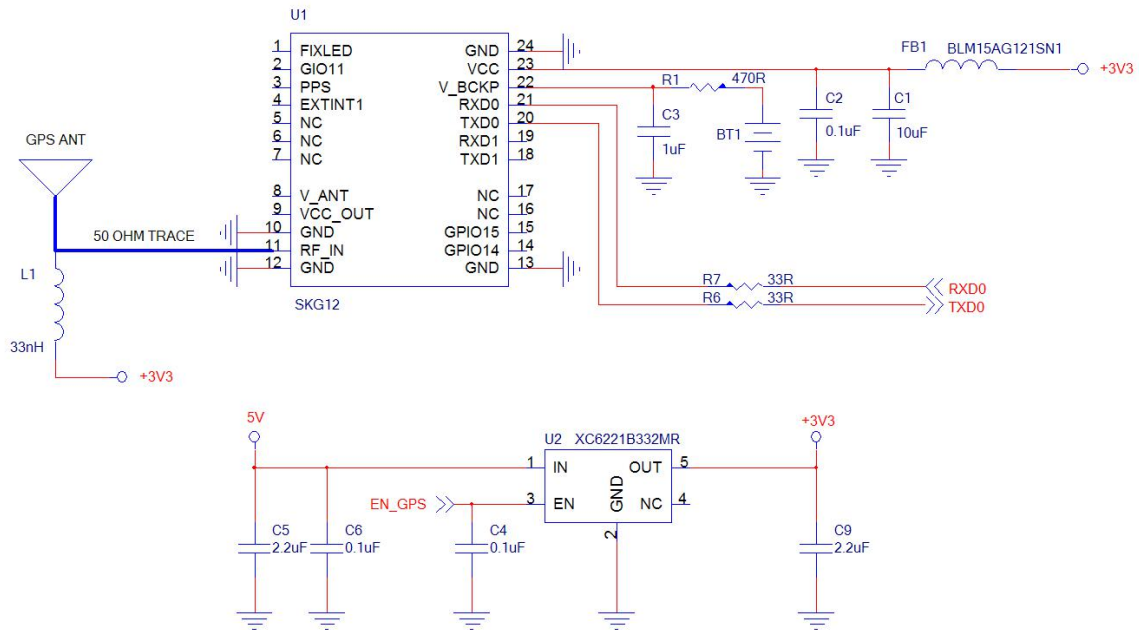

Figure 5: SKG12D Typical Reference design schematic

## 12.Packaging Specification

SKG12D modules are shipped in reel and with 1200 units per reel. Each tray is 'dry' package.

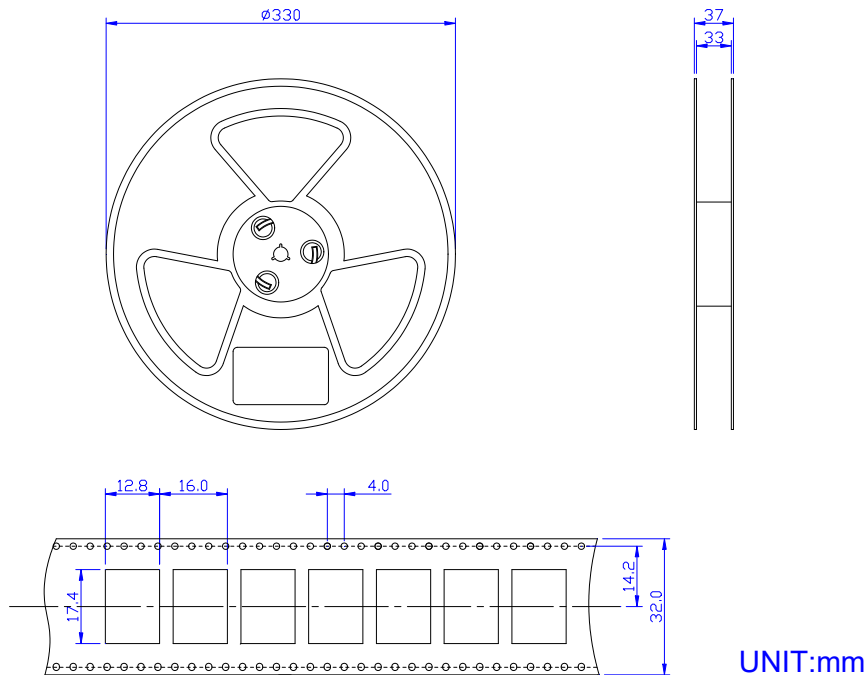
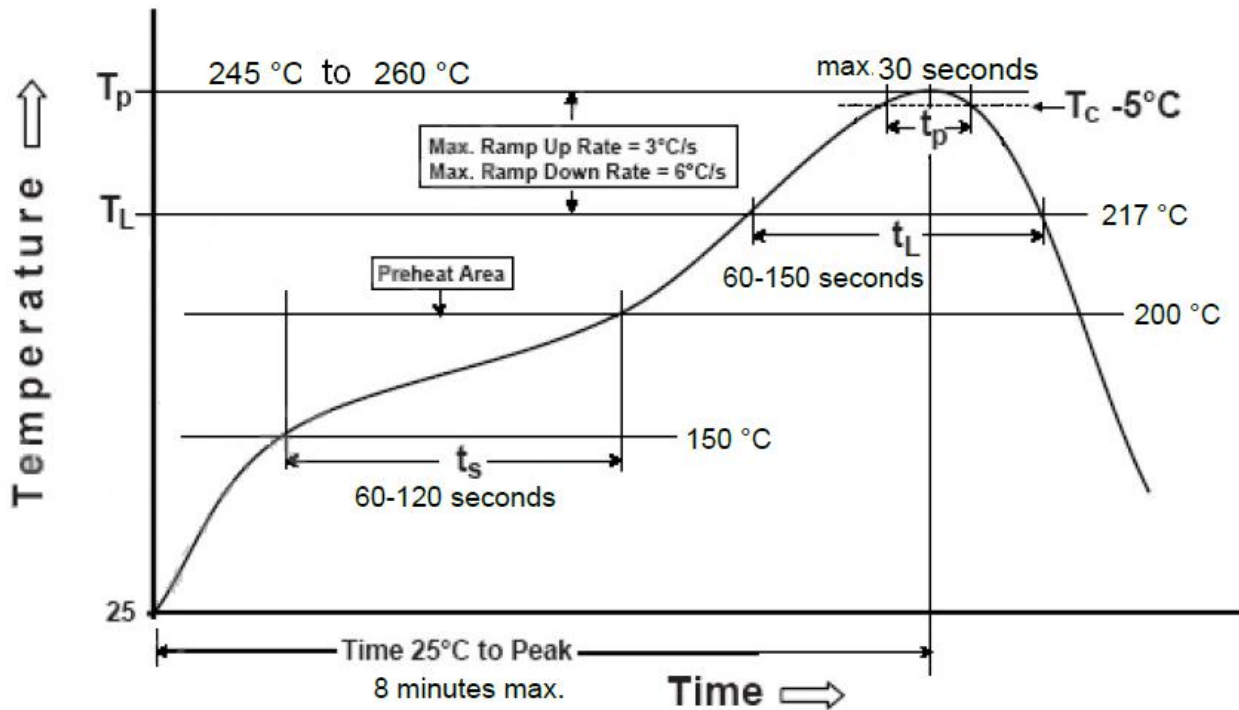

Figure 6: SKG12D Packaging



## 13. Manufacturing Process Recommendations



**Figure 7: SKG12D Typical Leadfree Soldering Profile**

**Note:** The final soldering temperature chosen at the factory depends on additional external factors like choice of soldering paste, size, thickness and properties of the baseboard, etc. Exceeding the maximum soldering temperature in the recommended soldering profile may permanently damage the module.

Soldering Paste: OM338 SAC405 / Nr.143714 (Cookson Electronics)

Alloy specification: Sn 95.5/ Ag 4/ Cu 0.5 (95.5% Tin/ 4% Silver/ 0.5% Copper)

**Melting Temperature: 217 °C**

**Stencil Thickness: 150um**

## 14. Software Protocol

### NMEA 0183 Protocol

The NMEA protocol is an ASCII-based protocol, Records start with a \$ and with carriage return/line feed. GPS specific messages all start with \$GNxxx where xxx is a three-letter identifier of the message data that follows. NMEA messages have a checksum, which allows detection of corrupted data transfers.

The Skylab SKG12D supports the following NMEA-0183 messages: GGA, GLL, GSA, GSV, RMC VTG, ZDA. The module default NMEA-0183 output is set up GGA、GSA、RMC、GSV , and default baud rate is set up 9600bps.

Table 1: NMEA-0183 Output Messages

NMEA Record	Description	Default
GNGGA	Global positioning system fixed data	Y
GNGLL	Geographic position—latitude/longitude	N
GPGSA	GNSS DOP and active satellites for GPS	Y
GLGSA	GNSS DOP and active satellites for GLONASS	Y
BDGSA	Beidou DOP and active satellites for BD	N
GPGSV	GNSS satellites in view for GPS	Y
GLGSV	GNSS satellites in view for GLONASS	Y
BDGSV	Beidou satellites in view for BD	N
GNRMC	Recommended minimum specific GNSS data	Y
GNVTG	Course over ground and ground speed	N
GNZDA	Date and Time	N

### GGA-Global Positioning System Fixed Data

This sentence contains the position, time and quality of the navigation fix.

See RMC for Fix Status, Fix Mode, Fix Date, Speed, and True Course.

See GSA for Fix Type, PDOP, and VDOP.

\$GNGGA,021514.000,2232.1799,N,11401.1823,E,1,6,1.25,84.0,M,-2.2,M,,\*6A

Table 2: GGA Data Format

Name	Example	Units	Description
Message ID	\$GNGGA		GGA protocol header
UTC Position	021514.000		hhmmss.sss
Latitude	2232.1799		ddmm.mmmm
N/S indicator	N		N=north or S=south
Longitude	11401.1823		dddmm.mmmm
E/W Indicator	E		E=east or W=west
Position Fix Indicator	1		See Table 2-1
Satellites Used	6		Range 0 to 12
HDOP	1.25		Horizontal Dilution of Precision
MSL Altitude	84.0	meters	Altitude (referenced to the Ellipsoid)
AltUnit	M	meters	Altitude Unit
GeoSep	-2.2	meters	Geoidal Separation
GeoSepUnit	M	meters	Geoidal Separation Unit
Age of Diff.Corr.	<Null>	second	Null fields when it is not Used
Diff.Ref.Station ID	<Null>		Null fields when it is not Used
Checksum	*6A		
EOL	<CR> <LF>		End of message termination

Table 2-1: Position Fix Indicators

Value	Description
0	Fix not available or invalid
1	fix valid
2	Differential GPS, fix valid

## GLL-Geographic Position – Latitude/Longitude

This sentence contains the fix latitude and longitude.

```
$GNGLL,2232.1799,N,11401.1824,E,021513.000,A,A*4E
```

Table 3: GLL Data Format

Name	Example	Units	Description
Message ID	\$GNGLL		GLL protocol header
Latitude	2232.1799		ddmm.mmmm
N/S Indicator	N		N=north or S=south
Longitude	11401.1824		dddmm.mmmm
E/W Indicator	E		E=east or W=west
UTC Position	021513.000		hhmmss.sss
Fix Status	A		A=data valid or V=data not valid
Fix Mode	A		A=autonomous, N = No fix, D=DGPS, E=DR
Checksum	*4E		
EOL	<CR> <LF>		End of message termination

## GSA-GNSS DOP and Active Satellites

This sentence contains the mode of operation, type of fix, PRNs of the satellites used in the solution as well as PDOP, HDOP and VDOP.

GPS GSA message: \$GPGSA,.....

```
$GPGSA,A,3,28,20,04,17,10,193,08,,,,,1.14,0.75,0.85*31
```

GLONASS GSA message: \$GLGSA,.....

```
$GLGSA,A,3,67,81,80,66,82,79,,,,,1.14,0.75,0.85*11
```

BD GSA message: \$BDGSA,.....

```
$BDGSA,A,3,10,,,,,,,,,1.54,1.26,0.88*17
```

Table 4: GSA Data Format

Name	Example	Units	Description
Message	\$GPGSA		GSA protocol header
Mode 1	A		See Table 4-2
Mode 2	3		See Table 4-1
ID of satellite used	28		Sv on Channel 1
ID of satellite used	20		Sv on Channel 2
...	...		...
ID of satellite used	<Null>		Sv on Channel 12 (Null fields when it is not Used)
PDOP	1.14		Position Dilution of Precision
HDOP	0.75		Horizontal Dilution of Precision
VDOP	0.85		Vertical Dilution of Precision
Checksum	*31		
EOL	<CR> <LF>		End of message termination

Table 4-1: Mode 2

Value	Description
1	Fix not available
2	2D Fix
3	3D Fix

Table 4-2: Mode 1

Value	Description
M	Manual-forced to operate in 2D or 3D mode
A	Automatic-allowed to automatically switch 2D/3D

## GSV-GNSS Satellites in View

This sentence contains the PRNs, azimuth, elevation, and signal strength of all satellites in view.

GPS GSV message: \$GPGSV,.....

\$GPGSV,4,1,14,28,86,009,35,193,70,056,38,04,44,258,29,17,44,338,44\*48

GLONASS GSV message: \$GLGSV,.....

\$GLGSV,3,1,10,79,42,239,15,66,40,076,31,67,37,143,29,81,33,025,14\*66

BD GSV message: \$BDGSV,.....

\$BDGSV,1,1,03,10,46,329,31,08,43,161,,09,40,217,\*52

Table 5: GSV Data Format

Name	Example	Units	Description
Message ID	\$GPGSV		GSV protocol header
Number of Message	4		Total number of GSV sentences (Range 1 to 3)
Message Number	1		Sentence number of the total (Range 1 to 3)
Satellites in View	14		Number of satellites in view
Satellite ID	28		Channel 1
Elevation	86	degrees	Channel 1(Range 00 to 90)
Azinmuth	009	degrees	Channel 1(Range 000 to 359)
SNR(C/NO)	35	dB-Hz	Channel 1(Range 00 to 99, null when not tracking)
...			...
Satellite ID	17		Channel 4
Elevation	44	degrees	Channel 4(Range 00 to 90)
Azimuth	338	degrees	Channel 4(Range 000 to 359)
SNR(C/NO)	44	dB-Hz	Channel 4(Range 00 to 99, null when not tracking)

Checksum	*48		
EOL	<CR> <LF>		End of message termination

Depending on the number of satellites tracked multiple messages of GSV data may be required.

## RMC-Recommended Minimum Specific GNSS Data

This sentence contains the recommended minimum fix information.

See GGA for Fix Quality, Sats Used, HDOP, Altitude, Geoidal Separation, and DGPS data.

See GSA for Fix Type, PDOP and VDOP.

\$GNRMC,023345.000,A,2232.1767,N,11401.1953,E,0.18,151.55,100410,,,A\*76

Table 6: RMC Data Format

Name	Example	Units	Description
Message ID	\$GNRMC		RMC protocol header
UTS Position	023345.000		hhmmss.sss
Status	A		A=data valid or V=data not valid
Latitude	2232.1767		ddmm.mmmm
N/S Indicator	N		N=north or S=south
Longitude	11401.1953		dddmm.mmmm
E/W Indicator	E		E=east or W=west
Speed Over Ground	0.18	Knots	
Course Over Ground	151.55	Degrees	True Course
Date(UTC)	100410		ddmmyy
Magnetic variation	<Null>	Degrees	Null fields when it is not Used
Magnetic Variation Direction	<Null>		E=east or W=west (Null fields when it is not Used)
Fix Mode	A		A=autonomous, N = No fix, D=DGPS, E=DR
Checksum	*76		

EOL	<CR> <LF>		End of message termination
-----	-----------	--	----------------------------

## VTG-Course Over Ground and Ground Speed

This sentence contains the course and speed of the navigation solution.

\$GNVTG,148.81,T,,M,0.13,N,0.24,K,A\*23

Table 7: VTG Data Format

Name	Example	Units	Description
Message ID	\$GPVTG		VTG protocol header
Tcourse	148.81	Degrees	True Course
Reference	T		T = True
Mcourse	<Null>	Degrees	Magnetic Course (Null fields when it is not Used)
Reference	M		M = Magnetic (Null fields when it is not Used)
Speed over ground	0.13	Knots	Nautical Miles per Hour
Units	N		Knots
Speed over ground	0.24	Km/hr	in Kilometers per Hour
Units	K		Kilometer per hour
Mode	A		A=Autonomous, N=No fix, D=DGPS, E=DR
Checksum	*23		
EOL	<CR> <LF>		End of message termination

## ZDA-Date and Time

This sentence contains UTC date & time, and local time zone offset information.

\$GNZDA,023345.000,10,04,2010,\*,\*4D

Table 8: ZDA Data Format

Name	Example	Units	Description
Message ID	\$GPZDA		ZDA protocol header



UTC Time	023345.000		hhmmss.sss
Day	10		UTC time: day (01 ... 31) dd
Month	04		UTC time: month (01 ... 12) mm
Year	2010		UTC time: year (4 digit year) yyyy
local zone hours	<null>		Local Time Zone Offset Hours (Null fields when it is not Used)
local zone minutes	<null>		Local Time Zone Offset Minutes (Null fields when it is not Used)
Checksum	*4D		
EOL	<CR> <LF>		End of message termination

## CMD List

Table 9: CMD List

CMD TYPE	CMD Example:
Hot Restart	\$PMTK101*32<CR><LF>
Warm Restart	\$PMTK102*31<CR><LF>
Cold Restart	\$PMTK103*30<CR><LF>
Full Cold Restart	\$PMTK104*37<CR><LF>
Search GLONASS satellites only	\$PMTK353,0,1,0,0,0*2A<CR><LF>
Search GPS satellites only	\$PMTK353,1,0,0,0,0*2A<CR><LF>
Search GPS and GLONASS satellites	\$PMTK353,1,1,0,0,0*2B<CR><LF>
Search BEIDOU satellites only	\$PMTK353,0,0,0,0,1*2A<CR><LF>
Search GPS and BEIDOU satellites	\$PMTK353,1,0,0,0,1*2B<CR><LF>

## 15 Contact Information

**Skylab M&C Technology Co., Ltd.**

深圳市天工测控技术有限公司

**Address:** 6 Floor, No.9 Building, Lijincheng Scientific & Technical park, Gongye East Road,  
Longhua District, Shenzhen, Guangdong, China

**Phone:** 86-755 8340 8210 (Sales Support)

**Phone:** 86-755 8340 8510 (Technical Support)

**Fax:** 86-755-8340 8560

**E-Mail:** [technicalsupport@skylab.com.cn](mailto:technicalsupport@skylab.com.cn)

**Website:** [www.skylab.com.cn](http://www.skylab.com.cn)    [www.skylabmodule.com](http://www.skylabmodule.com)