

WG217 802.11 a/b/g/n/ac USB WiFi Module Datasheet

Document Information

Title WG217 802.11 a/b/g/n/ac USB WiFi Module Datasheet

Document type Datasheet

Document number SL-18060071

Revision and date V1.06 20-Jul -2018

Disclosure restriction Public

Revision History

Revision	Description	Approved	Date
V1.01	Initial Release	George He	2017.07.25
V1.02	Update Performance Specification	George He	2017.11.21
V1.03	Update Performance Specification	George He	2017.12.01
V1.04	Update Performance Specification	George He	2017.12.13
V1.05	Update Top View Photo	George He	2018.01.09
V1.06	Update packaging information	George He	2018.07.20

Contents

1. General Description	4
2. Applications.....	4
3. Applications.....	5
4. Application Block Diagram	5
5. Module Pinout and Pin Description	6
6. Performance Specification	6
7. Module Pinout.....	8
8. Electrical Characteristics	8
9. PCB Footprint and Dimensions	9
10. Manufacturing Process Recommendations	10
11. Reference Design Schematic.....	11
12. Packaging Specification	11
12. Contact Information	12

1. General Description

WG217 is a highly integrated USB Wi-Fi module which supports 433Mbps PHY rate. It is compliant with IEEE 802.11ac draft specification, offering feature-rich wireless connectivity and reliable throughput from an extended distance.

WG217 is designed to support standard based features in the areas of security, quality of service and international regulations, giving end users the greatest performance any time and in any circumstance.



Figure 1: WG217 Top View

2. Applications

- ◆ IP Camera
- ◆ IP TV
- ◆ IP DVD(Internet VOD Player)
- ◆ Set Top Box
- ◆ Home Gateways
- ◆ Gaming Consoles
- ◆ DVR

3. Applications

- ◆ IEEE 802.11a/b/g/n/ac WLANs
- ◆ 2.4G /5G ITIR mode
- ◆ With support of 433Mbps PHY rate
- ◆ IEEE 802.11e QoS Enhancement(WLAN)
- ◆ USB LPM/Selective Suspend support
- ◆ Fully compliance with USB2.0 High-speed mode.
- ◆ IEEE 802.11i(WPA, WPA2). Open, shared key, and pair-wise key authentication services
- ◆ Supports for Windows XP 32/64, 2000, Vista 32/64bit, Windows 7 32/64bit, Linux, Android
- ◆ RoHS compliance meets nvironment-friendly requirement.
- ◆ FCC,CE compliance
- ◆ 36.0(L) x 15.0(W) x 3.2mm small dimension.

4. Application Block Diagram

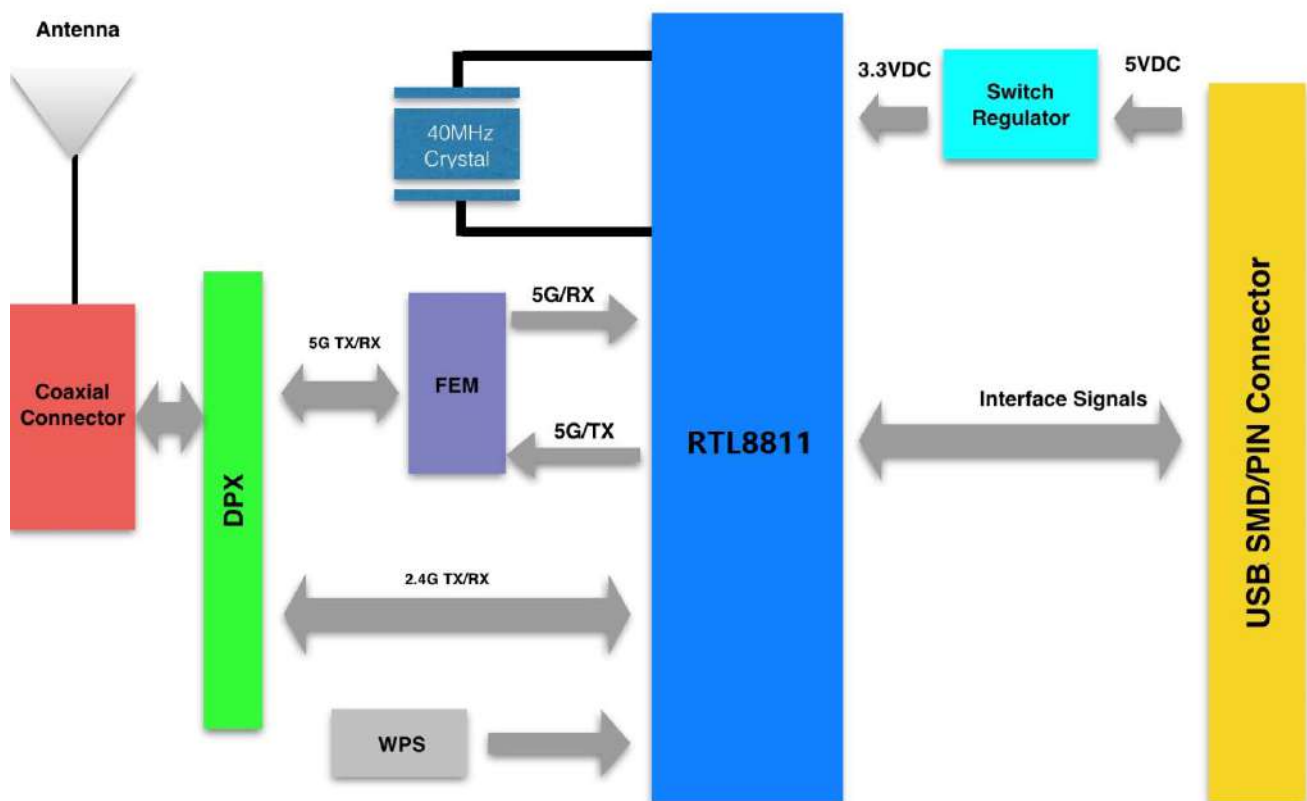
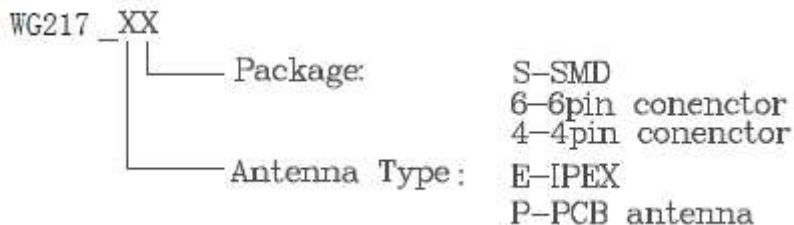

Figure 2: WG217 Block Diagram

5. Module Pinout and Pin Description



6. Performance Specification

Hardware Features	
Model	WG217
ANTENNA TYPE	IPEX connector or PCB antenna
Voltage	3.5—5.5V
DIMENSIONS(W×D)	36mm*15mm
Wireless Features	
WIRELESS STANDARDS	IEEE 802.11 a/b/g/n/ac
FREQUENCY RANGE	2.4/5GHz
DATA RATES	IEEE 802.11a Standard Mode: 6,9,12,18,24,36,48,54Mbps
	IEEE 802.11 b Standard Mode: 1,2,5.5,11Mbps
	IEEE 802.11g Standard Mode: 6,9,12,18,24,36,48,54Mbps
	IEEE 802.11n/Draft 2.0 Mode: 130Mbps @ HT20
	150Mbps @ HT40 IEEE 802.11ac Standard Mode: 433Mbps @ VHT80
2.4G RECEIVE SENSITIVITY	HT40 MCS15: -69dBm@10% PER(MCS7)
	HT20 MCS15 : -72dBm@10% PER(MCS7)

	54M: -74dBm@10% PER			
	11M: -89dBm@ 8% PER			
5G RECEIVE SENSITIVITY	VHT80 MCS15: -59dBm@10% PER(MCS9)			
	HT40 MCS15: -68dBm@10% PER(MCS7)			
	OFDM 54M: -75dBm@10% PER			
	OFDM 6M: -90dBm@ 8% PER			
MODULATION TECHNOLOGY	802.11 Legacy b/g/n			
	DSSS (DBPSK, DQPSK, CCK)			
	OFDM (BPSK, QPSK, 16-QAM, 64-QAM)			
	802.11ac			
	OFDM (256-QAM)			
WIRELESS SECURITY	Supports WEP64/128, WPA, WPA2, TKIP, WAPI, and AES hardware encryption			
5GHZ TRANSMIT POWER	IEEE 802.11ac: 11-14dBm @AC80 MCS7			
2.4GHZ TRANSMIT POWER	IEEE 802.11n: 14-17dBm @HT40 MCS7 14-17dBm@HT20 MCS7			
	IEEE 802.11g: 15-17dBm			
	IEEE 802.11b: 16-20dBm			
WORK MODE	AP/Ad-Hoc / Infrastructure mode			
Others				
POWER Consumption@25°C	Status	POWER	2.4G/mA	5G/mA
	Transmission HT40/MCS 15	5.0V	150	160
	Receiving HT40/MCS15	5.0V	90	90

SYSTEM REQUIREMENTS	Windows 7(32/64bits), Windows Vista(32/64bits), Windows XP(32/64bits), Windows 2000, Linux, Android
ENVIRONMENT	Operating Temperature: -10°C~70°C
	Storage Temperature: -40°C~125°C
	Operating Humidity: 10%~90% non-condensing
	Storage Humidity: 5%~90% non-condensing

7. Module Pinout



Figure 3: WG217 Pin Name

8. Electrical Characteristics

Pin No.	Pin name	I/O	Description	Remark
1	LED	O	LED pin	
2	GND	G	Ground	
3	D+	I/O	USB Interface DP	
4	D-	I/O	USB Interface DM	

5	VCC	P	Module Power Supply	
6	WPS	I	WPS pin	
7	NC			
8	NC			

9. PCB Footprint and Dimensions

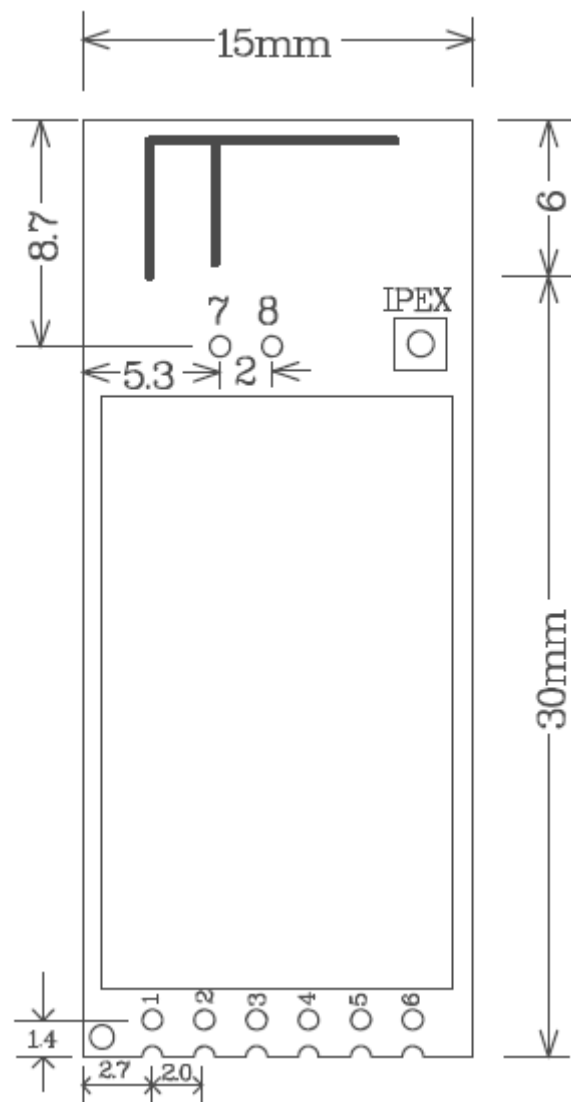

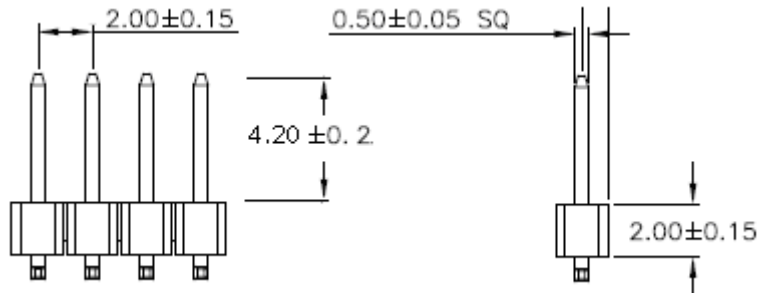

Figure 4: WG217 Dimensions

10. Manufacturing Process Recommendations

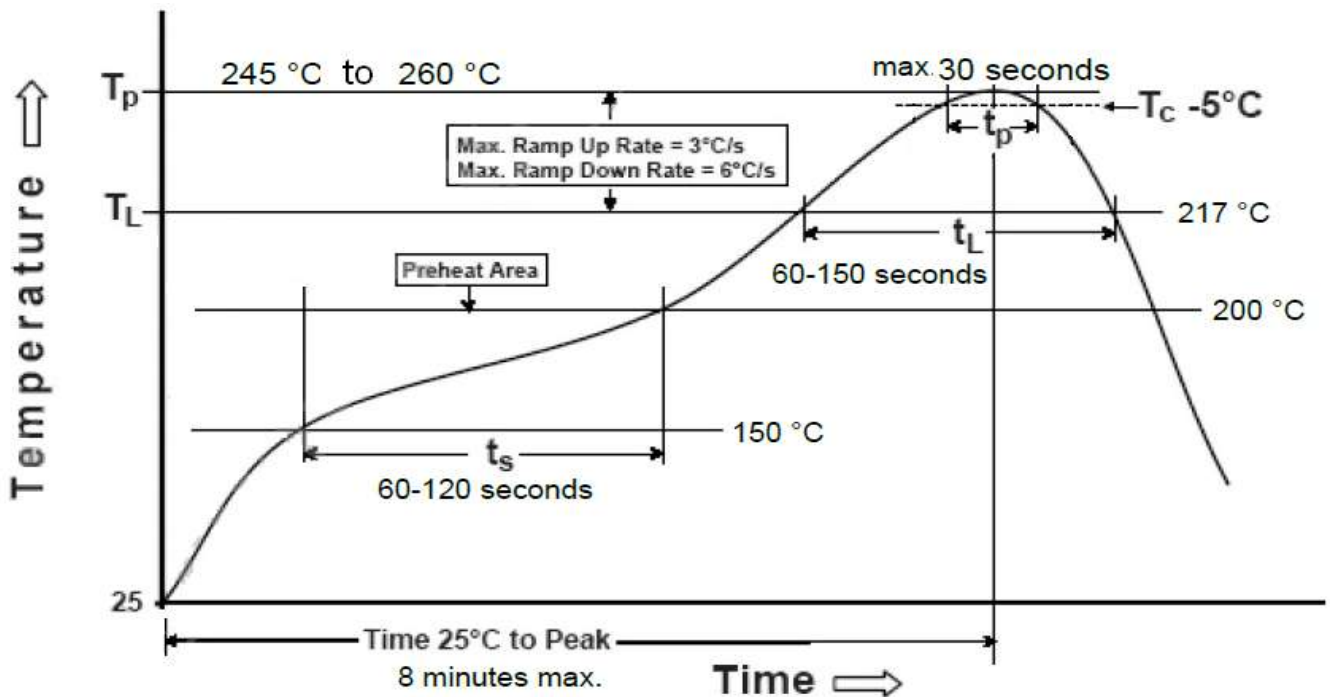

Figure 5: WG217 Typical Leadfree Soldering Profile

Note: The final soldering temperature chosen at the factory depends on additional external factors like choice of soldering paste, size, thickness and properties of the baseboard, etc. Exceeding the maximum soldering temperature in the recommended soldering profile may permanently damage the module.

11. Reference Design Schematic

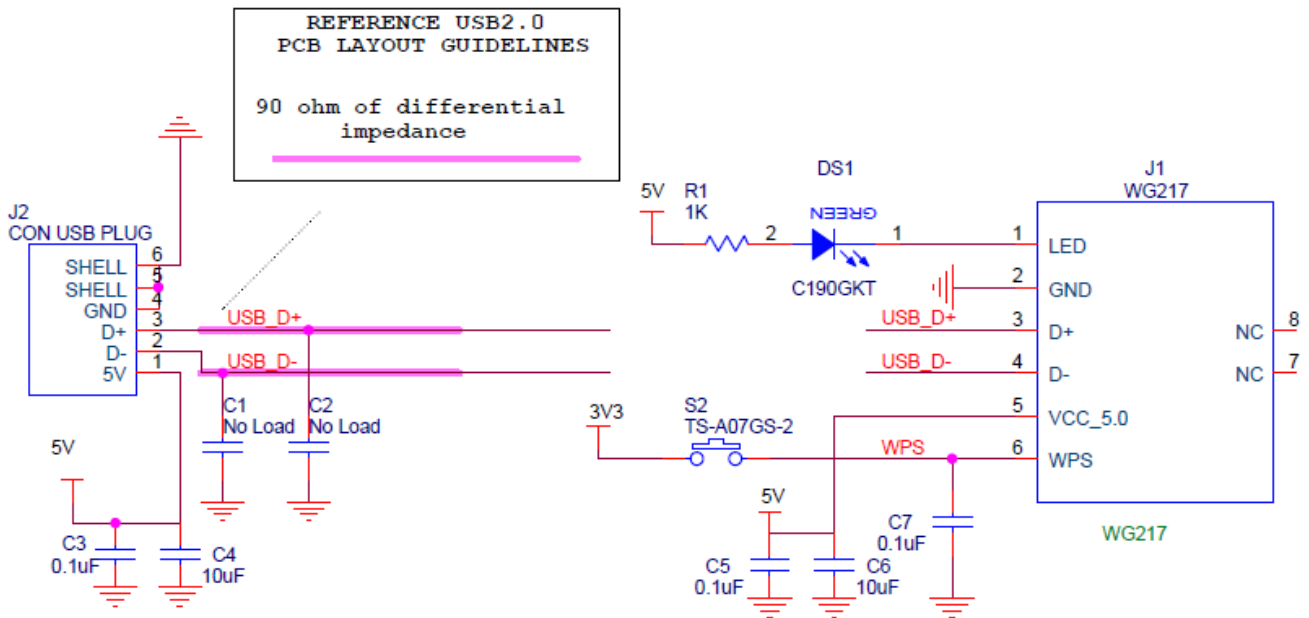

Figure 6: WG217 schematic application

12. Packaging Specification

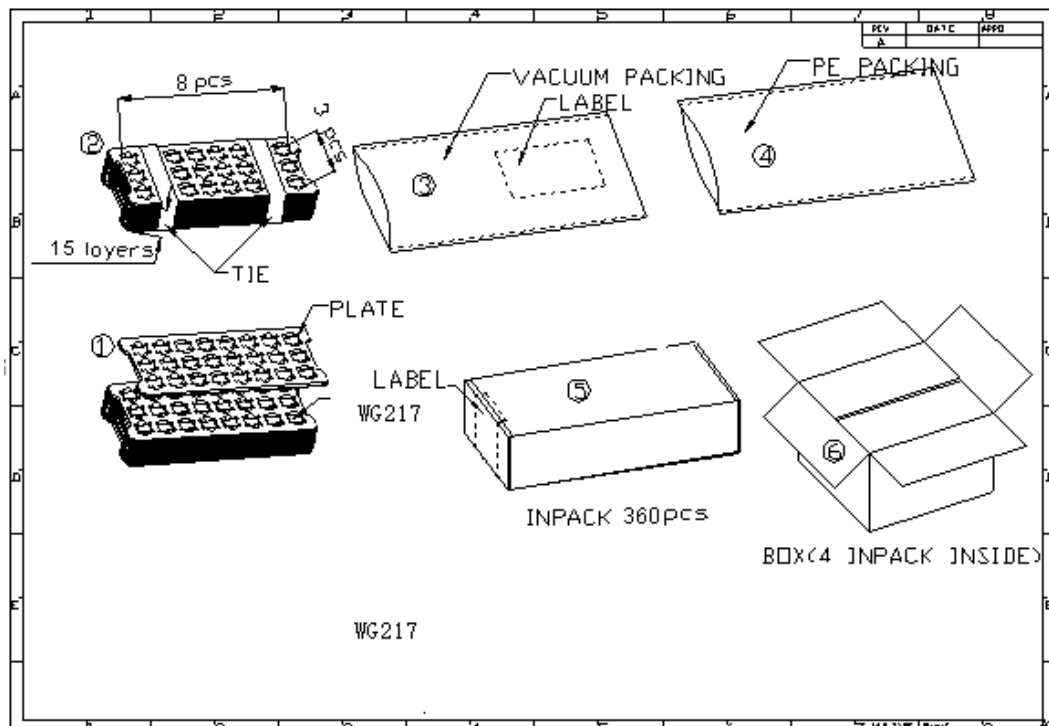

Figure 7: WG217 Packaging Specification

12. Contact Information

Skylab M&C Technology Co., Ltd.

深圳市天工测控技术有限公司

Address: 6Floor, No.9 Building, Lijincheng Scientific & Technical park, Gongye East Road,
Longhua District, Shenzhen, Guangdong, China

Phone: 86-755 8340 8210 (Sales Support)

Phone: 86-755 8340 8510 (Technical Support)

Fax: 86-755-8340 8560

E-Mail: technicalsupport@skylab.com.cn(技术支持)

Website: www.skylab.com.cn www.skylabmodule.com