

WG211 802.11 a/b/g/n/ac WLAN System Module Datasheet

Name: 802.11 a/b/g/n/ac WLAN System Module

Model NO.: WG211

Revision: V2.04



Revision History:

Revision	Description	Approved	Date
V1.01	Initial	George	20131105
V2.01	Update Size	George	20151226
V2.02	Update soldering temperature	George	20160418
V2.03	Update photo Information	George	20160526
V2.04	Update certification information	George	20170831

General Description

WG211 is a highly integrated Wi-Fi single chip which supports 433Mbps PHY rate. It is compliant with IEEE 802.11ac draft specification, offering feature-rich wireless connectivity and reliable throughput from an extended distance.

WG211 is designed to support standard based features in the areas of security, quality of service and international regulations, giving end users the greatest performance any time and in any circumstance.

Applications

- IP Camera
- IP TV
- IP DVD(Internet VOD Player)
- Set Top Box
- Home Gateways
- Gaming Consoles
- DVR

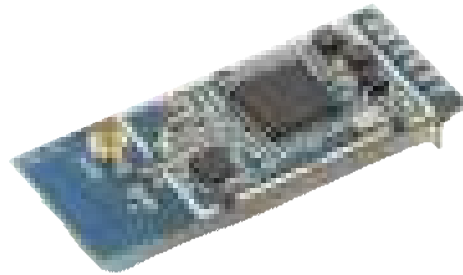

Features

- IEEE 802.11a/b/g/n/ac WLANs
- 2.4/5G ITIR mode
- With support of 433Mbps PHY rate
- Compliant IEEE802.11d and 802.11h
- Complies with USB2.1 specifications
- Fully compliance with USB2.0 High-speed mode.
- Security: WEP 64/128, WPA, WPA2, TKIP, AES, WAPI
- Supports for Windows XP 32/64, 2000, Vista 32/64bit, Windows 7 32/64bit, Linux, Android
- RoHS compliance meets environment-friendly requirement.
- FCC,CE compliance.
- 36.0(L) x 15.0(W) x 3.2mm small dimension

Module Internal Block Diagram

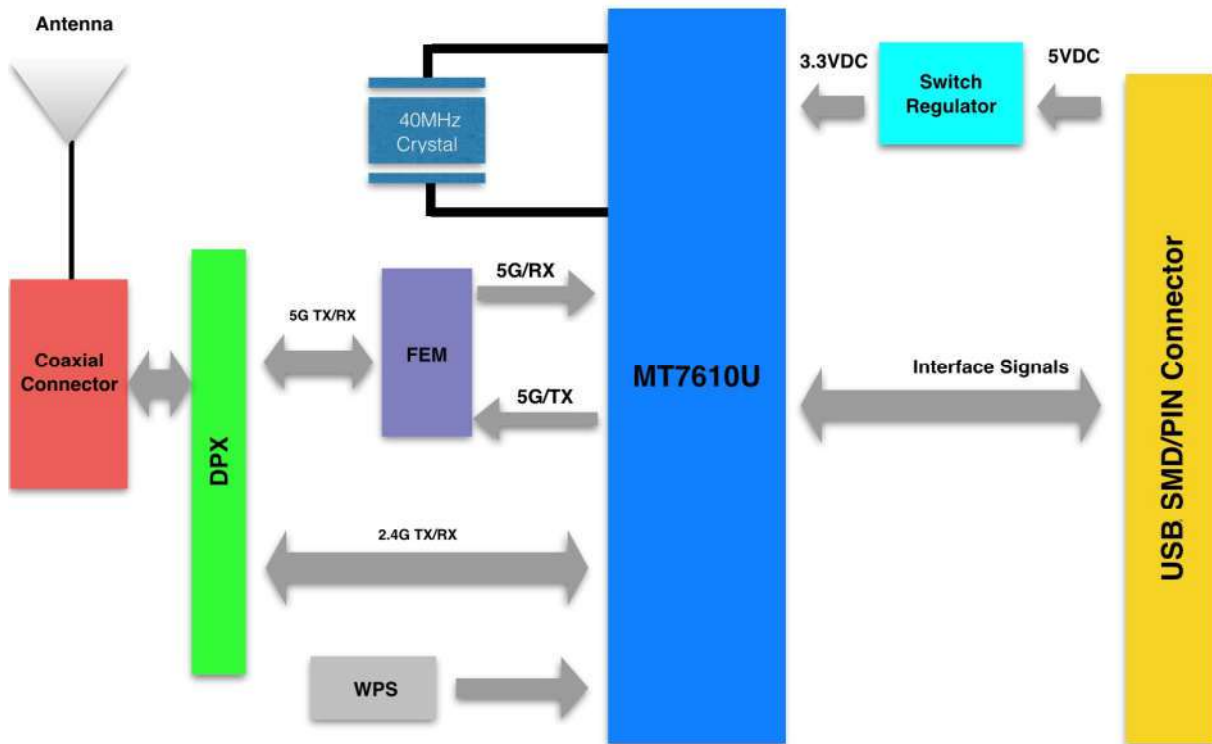

Ordering Information

WG211_XX

Package:	S-SMD
	6-6pin conenctor
	4-4pin conenctor
Antenna Type :	E-IPEX
	P-PCB antenna

Performance Specification

Hardware Features	
Model	WG211
ANTENNA TYPE	IPEX connector or PCB antenna
Chipset solution	MT7610U
Voltage	3.5—5.5V
DIMENSIONS(W×D)	36mm*15mm
Wireless Features	
WIRELESS STANDARDS	IEEE 802.11 a/b/g/n/ac
FREQUENCY RANGE	2.4/5GHz
DATA RATES	IEEE 802.11a Standard Mode: 6,9,12,18,24,36,48,54Mbps
	IEEE 802.11 b Standard Mode: 1,2,5.5,11Mbps
	IEEE 802.11g Standard Mode: 6,9,12,18,24,36,48,54Mbps
	IEEE 802.11n/Draft 2.0 Mode: 130Mbps @ HT20
	150Mbps @ HT40 IEEE 802.11ac Standard Mode: 460Mbps @VHT80
2.4G RECEIVE SENSITIVITY	HT40 MCS15: -72dBm@10% PER(MCS7)
	HT20 MCS15 : -75dBm@10% PER(MCS7)
	54M: -77dBm@10% PER
	11M: -90dBm@ 8% PER
5G RECEIVE SENSITIVITY	VHT80 MCS15: -62dBm@10% PER(MCS9)
	HT40 MCS15: -71dBm@10% PER(MCS7)
	OFDM 54M: -75dBm@10% PER
	OFDM 6M: -90dBm@ 8% PER
MODULATION TECHNOLOGY	802.11 Legacy b/g/n
	DSSS (DBPSK, DQPSK, CCK)
	OFDM (BPSK, QPSK, 16-QAM, 64-QAM)
	802.11ac
	OFDM (256-QAM)
WIRELESS SECURITY	Supports WEP64/128, WPA, WPA2, TKIP, WAPI, and AES hardware encryption
WIRELESS TRANSMIT POWER	IEEE 802.11ac: 9-11dBm @HT80 MCS7
	IEEE 802.11n: 12-15dBm @HT40 MCS7
With tolerance ±2dBm	12-15dBm@HT20 MCS7

	IEEE 802.11g: 15dBm			
	IEEE 802.11b: 17dBm			
WORK MODE	AP/Ad-Hoc / Infrastructure mode			
Others				
CERTIFICATION	RoHS, FCC, CE			
POWER Consumption@25°C	Status	POWER	2.4G/mA	5G/mA
	Transmission HT40/MCS 15	5.0V	150	160
	Receiving HT40/MC 15	5.0V	90	90
SYSTEM REQUIREMENTS	Windows 7(32/64bits), Windows Vista(32/64bits), Windows XP(32/64bits), Windows 2000, Linux, Android			
ENVIRONMENT	Operating Temperature: -10°C~70°C (14°F~158°F)			
	Storage Temperature: -40°C~125°C (-40°F~257°F)			
	Operating Humidity: 10%~90% non-condensing			
	Storage Humidity: 5%~90% non-condensing			

Module Pinout

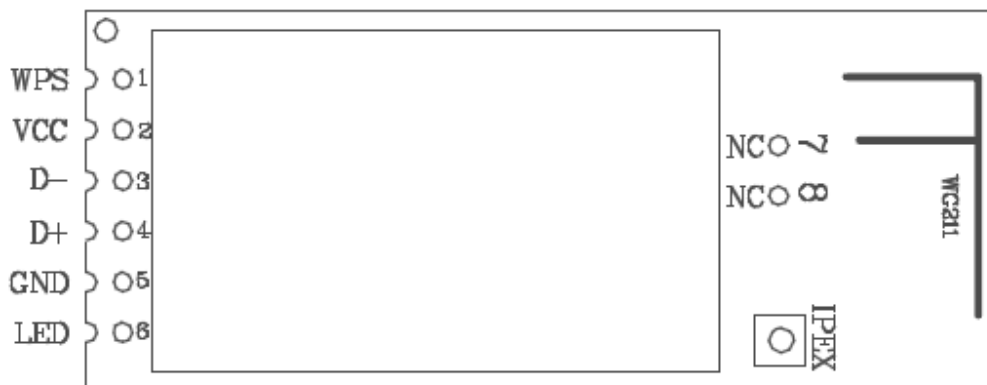

Pin Description

Pin No.	Pin name	I/O	Description	Remark
1	WPS	I	WPS pin	
2	VCC	P	Module Power Supply	
3	D-	I/O	USB Interface DM	
4	D+	I/O	USB Interface DP	
5	GND	G	Ground	
6	LED	O	LED pin	
7	NC			
8	NC			

PCB Footprint and Dimensions

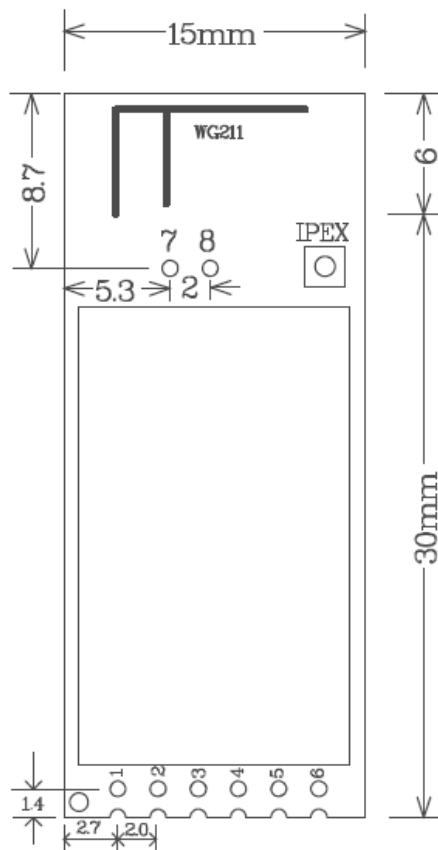

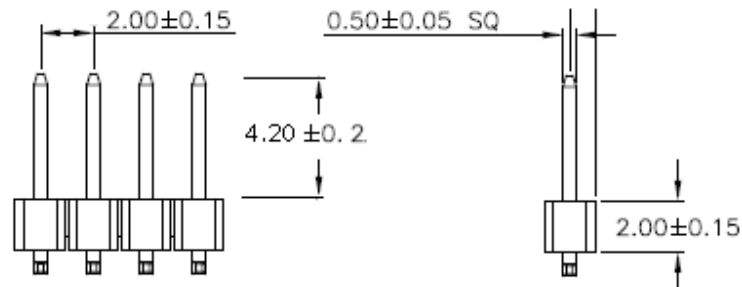

Manufacturing Process Recommendations

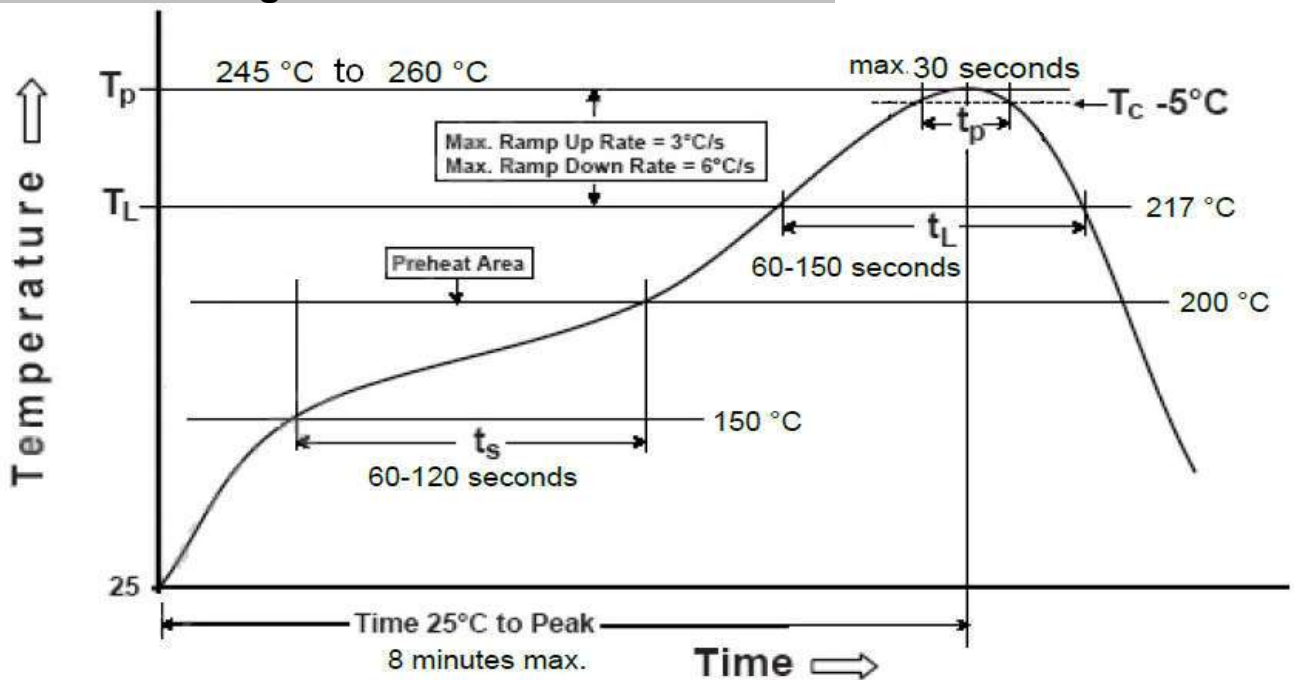

WG211 Typical Leadfree Soldering Profile

Note: The final soldering temperature chosen at the factory depends on additional external factors like choice of soldering paste, size, thickness and properties of the baseboard, etc. Exceeding the maximum soldering temperature in the recommended soldering profile may permanently damage the module.

Reference design schematic

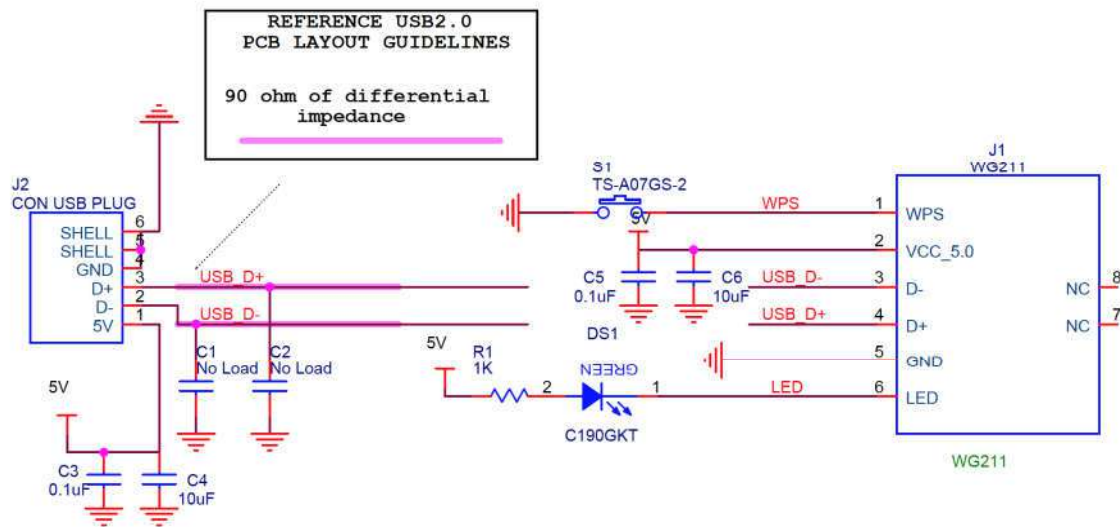

Skylab M&C Technology Co., Ltd.
深圳市天工测控技术有限公司

Address: 6 Floor, No.9 Building, Lijincheng Scientific & Technical park, Gongye East Road, Longhua District, Shenzhen, Guangdong, China

Phone: 86-755 8340 8210 (Sales Support)

Phone: 86-755 8340 8510 (Technical Support)

Fax: 86-755-8340 8560

E-Mail: sales1@skylab.com.cn

Website: www.skylab.com.cn www.skylabmodule.com.cn