

SKW99 规格书

2x2 MIMO WLAN 模块/

SKW99 Datasheet

2x2 MIMO WLAN Module

文档信息 Document information

| | |
|-----------------------------|--------------------------------------|
| 标题 Title | SKW99 规格书 2x2 MIMO WLAN 模块 |
| | SKW99 Datasheet 2x2 MIMO WLAN Module |
| 文档类型 Document type | 规格书 Datasheet |
| 文档编号 Document number | SL-18030027 |
| 版本及日期 Version and date | V2.03 24-Apr-2023 |
| 秘密等级 Disclosure restriction | 外部公开/ External public |

版本历史 Revision history

| 版本 Revision | 描述 Description | 审查 Approved | 日期 Date |
|-------------|---------------------------------|-------------|----------|
| V1.01 | 初始发布 Initial Release | George He | 20180130 |
| V1.02 | 更新包装信息/Update Packaging | George He | 20180410 |
| V1.03 | 更新尺寸 Update Dimension | George He | 20180411 |
| V1.04 | 更新尺寸 Update Dimension | George He | 20180413 |
| V1.05 | 更新无线特性 Update Wireless Features | George He | 20180605 |
| V1.06 | 更新引脚描述 Update Pin Description | George He | 20180930 |
| V1.07 | 更新引脚描述 Update Pin Description | George He | 20200927 |
| V2.01 | 更新格式 Update the format | Wendy | 20210623 |
| V2.02 | 更新产品图 Update product picture | Wendy | 20220818 |
| V2.03 | 增加中文 Add Chinese | Wendy | 20230424 |

SKYLAB 保留本文档及本文档所包含的信息的所有权利。SKYLAB 拥有本文档所述的产品、名称、标识和设计的全部知识产权。严禁没有征得 SKYLAB 的许可的情况下复制、使用、修改或向第三方披露本文档的全部或部分内容。

SKYLAB 对本文档所包含的信息的使用不承担任何责任。没有明示或暗示的保证，包括但不限于关于信息的准确性、正确性、可靠性和适用性。SKYLAB 可以随时修订这个文档。可以访问 www.skylab.com.cn 获得最新的文件。

Copyright © 2022, 深圳市天工测控技术有限公司。

SKYLAB® 是深圳市天工测控技术有限公司在中国的注册商标。

SKYLAB reserves all rights to this document and the information contained herein. Products, names, logos and designs described herein may in whole or in part be subject to intellectual property rights. Reproduction, use, modification or disclosure to third parties of this document or any part thereof without the express permission of SKYLAB is strictly prohibited.

The information contained herein is provided “as is” and SKYLAB assumes no liability for the use of the information. No warranty, either express or implied, is given, including but not limited, with respect to the accuracy, correctness, reliability and fitness for a particular purpose of the information. This document may be revised by SKYLAB at any time. For most recent documents, visit www.skylab.com.cn.

Copyright © 2018, Skylab M&C Technology Co., Ltd.

SKYLAB® is a registered trademark of Skylab M&C Technology Co., Ltd in China.

Contents

| | |
|---|----|
| 1 简述 General Description | 4 |
| 2 应用 Applications | 5 |
| 3 特性 Features | 5 |
| 4 Application Block Diagram | 6 |
| 5 接口 Interfaces | 6 |
| USB | 6 |
| UART | 6 |
| GPIO | 7 |
| WAN/LAN | 7 |
| 6 模块性能 Module Specifications | 7 |
| 7 模块引脚定义 Module pin definition | 9 |
| 模块引脚 Module Pinout | 9 |
| 引脚描述 Pin Description | 9 |
| 8 PCB 封装和尺寸/ PCB Footprint and Dimensions | 12 |
| 9 电气特性 Electrical Characteristics | 13 |
| a) 绝对最大额定参数 Absolute Maximum Ratings | 13 |
| b) 推荐的工作条件 Recommended Operation Ratings | 14 |
| c) 测量条件/ Measurement Conditions | 14 |
| 10 包装规范 Packaging Specification | 14 |
| 11 订购信息 Ordering Information | 15 |
| 12 联系信息 Contact Information | 15 |

1 简述 General Description

SKW99 模块包括一个 802.11n MAC 和基带，一个 2.4GHz 无线电和 FEM，一个 650MHz MIPS CPU，一个 2 端口 10/100 快速以太网交换机。解决方案适用于低功耗、低成本、高集成度的 AP 路由器和消费类电子设备，该模块只需要外接 3.3V 电源。它支持 802.11n 在 20 MHz 和 40 MHz 信道下分别高达 144Mbps 和 300Mbps，以及 IEEE 802.11b/g 数据速率。

The SKW99 module includes an 802.11n MAC and baseband, a 2.4GHz radio and FEM, a 650MHz MIPS CPU, a 2-port 10/100 fast Ethernet switch. Solution for low power, low-cost, and highly integrated AP router and consumer electronic devices, the module requires only an external 3.3V power supply. It supports 802.11n operating up to 144Mbps for 20 MHz and 300Mbps for 40 MHz channel respectively, and IEEE 802.11b/g data rates.

该模块支持网桥模式、AP Client 模式和 Gateway 模式。高性能模块可以毫不费力地处理高级应用，如路由、安全和 VoIP。它还包括支持各种应用程序的接口选择，例如用于访问外部存储和 3G/TLE 调制解调器的 USB 端口。特别是在物联网方面，应用范围广泛。

The module supports bridge mode and AP Client mode and Gateway mode. The high performance Module can process advanced applications effortlessly, such as routing, security and VoIP. It also includes a selection of interface to support a variety of applications, such as a USB port for accessing external storage and 3G/TLE modem. Especially in the IOT, a wide range of applications.

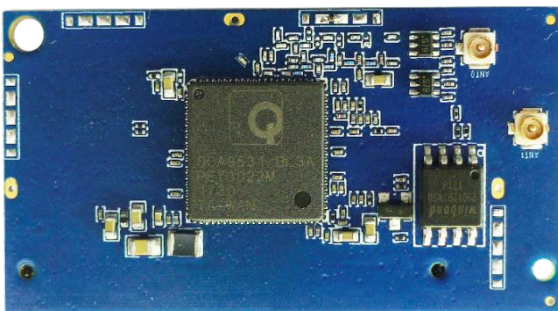

常规款俯视图 Top View conventional

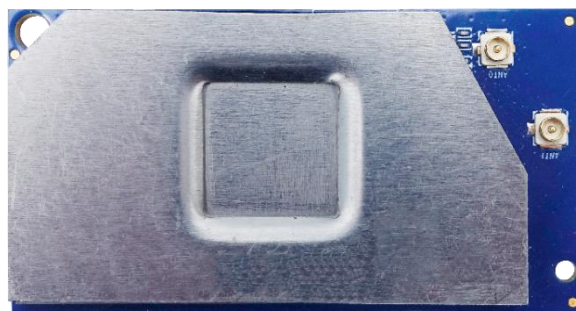

带屏蔽件俯视图 Top View with shield

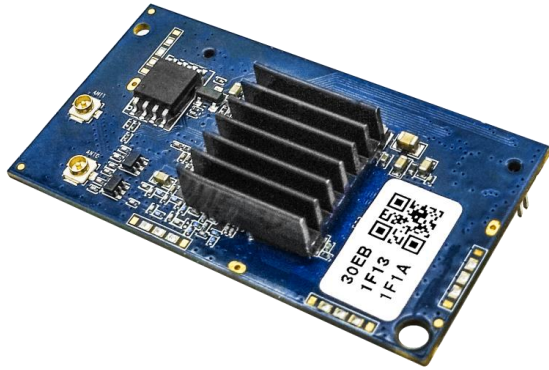

带散热器俯视图 Top View with heat sink

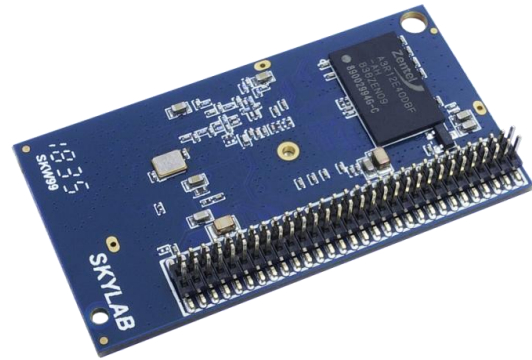

仰视图 Bottom View

Figure 1: SKW99 产品图片 SKW99 product picture

2 应用 Applications

- ◆ USB WiFi 摄像头/ USB WiFi Camera
- ◆ IOT (物联网) / IOT (internet of things)
- ◆ WiFi AP
- ◆ 3G/4G Wi-Fi 路由器 / 3G/4G Wi-Fi Router
- ◆ WiFi 中继器/ WiFi Repeater
- ◆ 建筑自动化/ Building Automation
- ◆ 家庭自动化/ Home Automation
- ◆ 智能家居网关/ Smart Home Gateway
- ◆ 工业控制/ Industry Control

3 特性 Features

- ◆ 符合 IEEE 802.11b/g/n / Compliant to IEEE 802.11b/g/n
- ◆ 2T2R 模式，支持 300Mbps 的 PHY 数据速率/ 2T2R mode with support for a 300Mbps PHY data rate
- ◆ DDR2 内存，最高可达 1024Mb / DDR2 memory up to 1024Mb
- ◆ 闪存，最高可达 256Mb / Flash memory up to 256Mb
- ◆ 4 个 LAN 端口和 1 个 WAN 端口 / 4 LAN ports and 1 WAN port
- ◆ 支持 USB 2.0 从设备的 u 盘和 USB 3G/4G 适配器和 USB 摄像头 / Support USB 2.0 slave device for USB disk and USB 3G/4G dongle and USB camera
- ◆ 安全等级 / Security: WEP64/128, TKIP, AES, WPA, WPA2, WAPI
- ◆ 支持 AP/客户端/路由器模式 / Support AP/Client/Router mode

- ◆ 符合 ROHS 环保要求/ ROHS compliance meets environment-friendly requirement
- ◆ 符合 FCC/CE/IC/ROHS 认证标准/ Conform to FCC/CE/IC/ROHS certification standards
- ◆ 小尺寸 48.4(L) x 25.7(W) x 9.0(H) mm/ 48.4(L) x 25.7(W) x 9.0(H) mm small dimension

4 Application Block Diagram

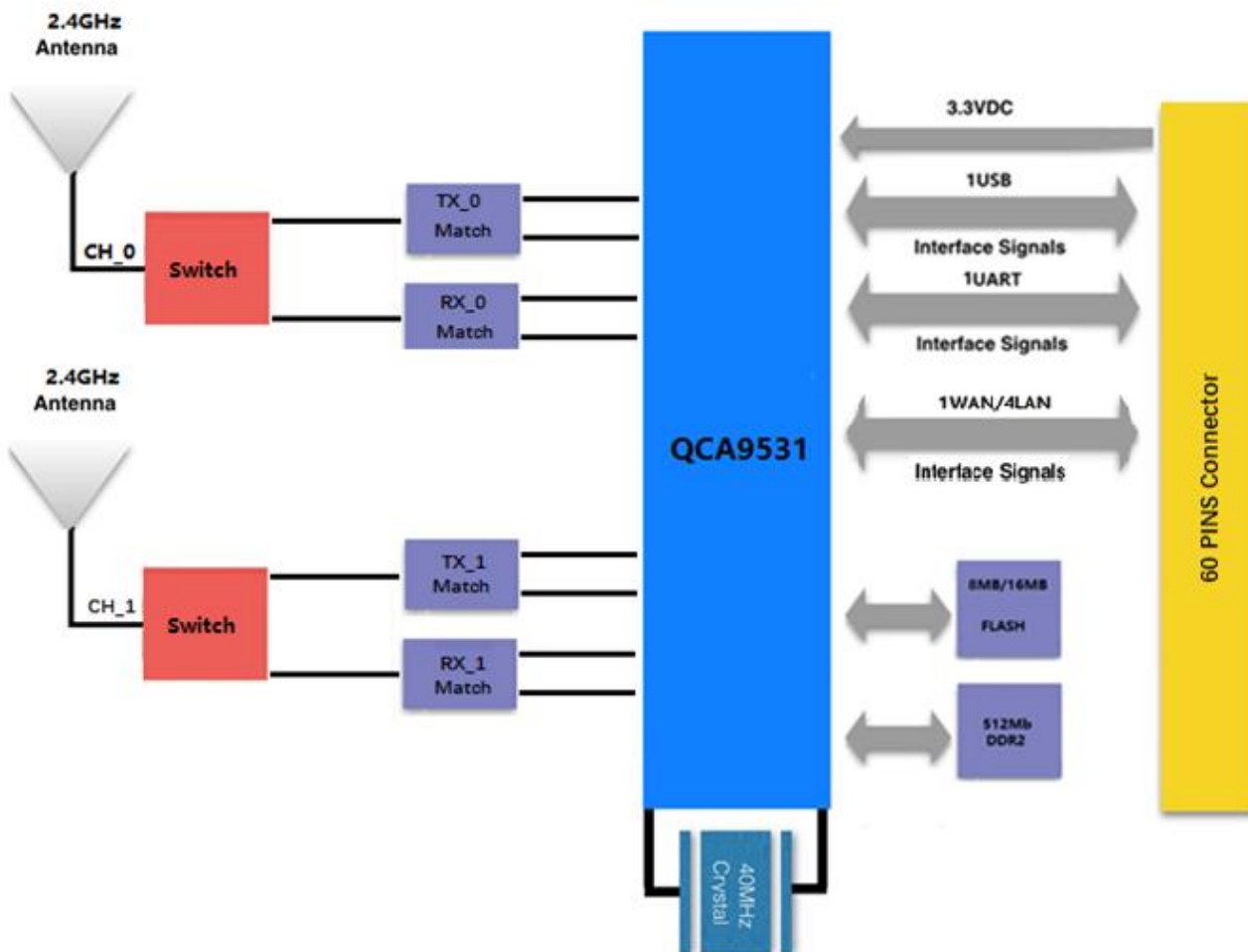

Figure 2: SKW99 框图/ SKW99 Block Diagram

5 接口 Interfaces

USB

USB 接口支持 USB 从设备的 U 盘和 USB 3G/4G 适配器和 USB 摄像头。

The USB interface support USB slave devices for USB disk and USB 3G/4G dongle and USB camera.

UART

UART 的默认波特率为 115200 bps。

The UART default baud rate is 115200bps.

GPIO

| 引脚序号/Pin NO. | GPIO | 描述/Description | 共享功能 Share function |
|--------------|--------|-------------------------------|---------------------|
| 24 | GPIO0 | GPIO0 | |
| 26 | GPIO1 | GPIO1 | |
| 28 | GPIO2 | GPIO2 | |
| 44 | | RESET_CONFIG | |
| 46 | GPIO17 | JUMPSTART | |
| 54 | GPIO4 | LED7/WAN LED, do not pull up. | LED |
| 53 | GPIO16 | LED6/LAN1 LED | |
| 8 | GPIO15 | LED5/LAN2 LED | |
| 6 | GPIO14 | LED4/LAN3 LED | |
| 40 | GPIO13 | LED1/SYSTEM LED | |
| 4 | GPIO11 | LED3/LAN4_LED | |
| 55 | GPIO12 | LED0/Wireless LED | |

WAN/LAN

SKW99 模块集成了 5 端口 10/100Mbps 的快速以太网交换机。

The SKW99 module integrates 5-port 10/100Mbps fast Ethernet switch.

6 模块性能 Module Specifications

| 硬件特性 Hardware Features | |
|------------------------|--|
| 型号 Model | SKW99 |
| 天线类型 Antenna Type | IPEX |
| 电源 Voltage | 3.3V±5% |
| 尺寸 Dimension(L×W×H) | 48.4mm*25.8mm*9.0mm |
| 无线特性 Wireless Features | |
| 无线标准 Wireless | IEEE 802.11b/g/n |
| 频率范围 Frequency | 2412GHz---2484MHz |
| 数据速率 Data Rates | IEEE 802.11b : 1,2,5.5,11Mbps |
| | IEEE 802.11g : 6,9,12,18,24,36,48,54Mbps |

| | |
|-------------------------------|---|
| | IEEE 802.11n : MCS0--MCS7 @ HT20 |
| | MCS0--MCS7 @ HT40 |
| 接收灵敏度 Receiver Sensitivity | HT40 MCS7 : -69dBm@10% PER(MCS7) |
| | HT20 MCS7 : -71dBm@10% PER(MCS7) |
| | 54M: -75dBm@10% PER |
| | 11M: -88dBm@ 8% PER |
| 调制技术 Modulation Technique | DSSS (DBPSK, DQPSK, CCK) |
| | OFDM (BPSK, QPSK, 16-QAM, 64-QAM) |
| 无线安全 Wireless Security | WPA/WPA2, WEP, TKIP and AES, WPS2.0, WAPI |
| 传输功率 Transmit Power | IEEE 802.11n: 13-16dBm @HT20/40 MCS7 |
| | IEEE 802.11g: 14-17dBm @54MHz |
| | IEEE 802.11b: 16-20dBm @11MHz |
| 工作模式 Work Mode | Bridge/Gateway/AP Client |
| 其他 Others | |
| 认证 Certification | ROHS |
| 环境 Environment | 工作温度 Operating Temperature: -20℃~55℃ |
| | 存储温度 Storage Temperature: -40℃~85℃ |
| | 工作湿度 Operating Humidity: 10%~90% non-condensing |
| | 存储湿度 Storage Humidity: 5%~90% non-condensing |

7 模块引脚定义 Module pin definition

模块引脚 Module Pinout

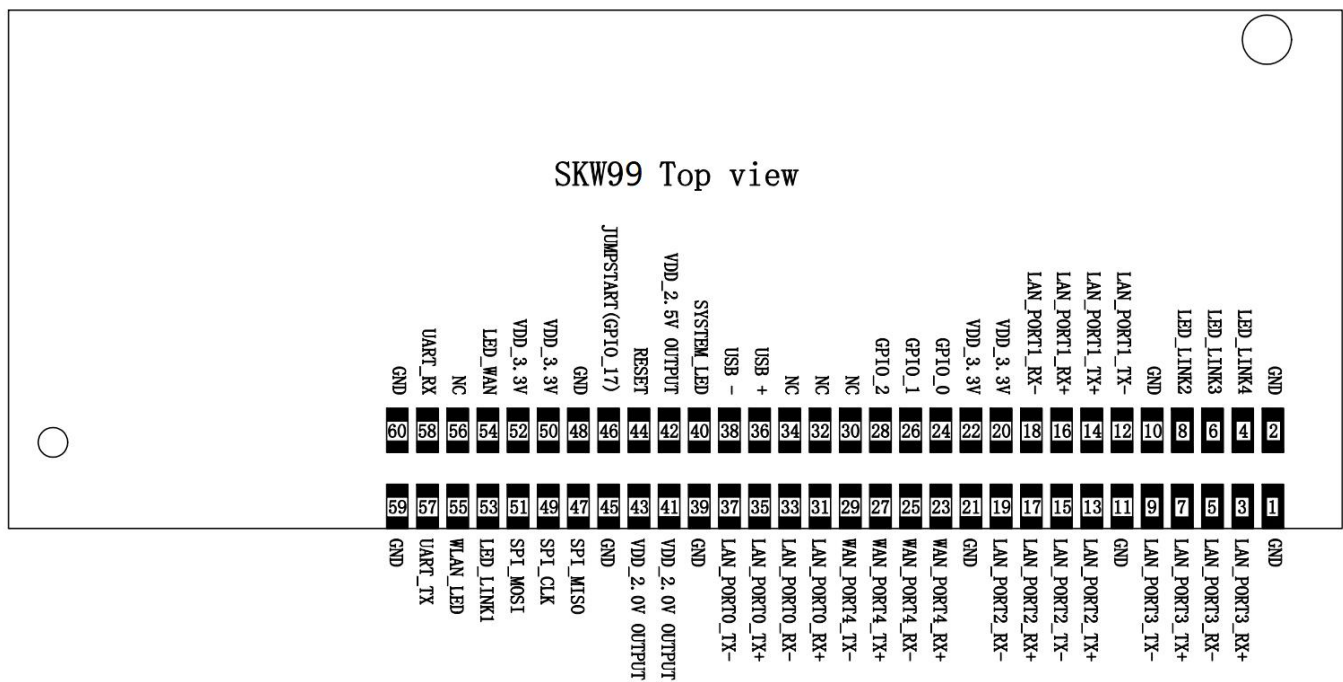

Figure 3: SKW99 引脚封装/ SKW99 Pin Package

引脚描述 Pin Description

| 序号/No. | 引脚名/Pin name | 描述/ Description |
|--------|---------------|-------------------------------|
| 1 | GND | Groud |
| 2 | GND | Groud |
| 3 | LAN_PORT3_RX+ | Ethernet port |
| 4 | LED_LINK4 | Port #3 activity LED, GPIO#11 |
| 5 | LAN_PORT3_RX- | Ethernet port |
| 6 | LED_LINK3 | Port #2 activity LED, GPIO#14 |
| 7 | LAN_PORT3_TX+ | Ethernet port |
| 8 | LED_LINK2 | Port #1 activity LED, GPIO#15 |
| 9 | LAN_PORT3_TX- | Ethernet port |
| 10 | GND | Groud |
| 11 | GND | Groud |

| | | |
|----|---------------|--|
| 12 | LAN_PORT1_TX- | Ethernet port |
| 13 | LAN_PORT2_TX+ | Ethernet port |
| 14 | LAN_PORT1_TX+ | Ethernet port |
| 15 | LAN_PORT2_TX- | Ethernet port |
| 16 | LAN_PORT1_RX+ | Ethernet port |
| 17 | LAN_PORT2_RX+ | Ethernet port |
| 18 | LAN_PORT1_RX- | Ethernet port |
| 19 | LAN_PORT2_RX- | Ethernet port |
| 20 | VDD_3.3V | 3.3V input 1000mA, recommended voltage 3.3V,Min2.97V, MAX |
| 21 | GND | Ground |
| 22 | VDD_3.3V | 3.3V input 1000mA, recommended voltage 3.3V,Min2.97V, MAX 3.63V |
| 23 | WAN_PORT4_RX+ | Ethernet Wan port |
| 24 | GPIO_0 | GPIO#0 |
| 25 | WAN_PORT4_RX- | Ethernet Wan port |
| 26 | GPIO_1 | GPIO#1 |
| 27 | WAN_PORT4_TX+ | Ethernet Wan port |
| 28 | GPIO_2 | GPIO#2 |
| 29 | WAN_PORT4_TX- | Ethernet Wan port |
| 30 | NC | No Connect |
| 31 | LAN_PORT0_RX+ | Ethernet port |
| 32 | NC | NC |
| 33 | LAN_PORT0_RX- | Ethernet port |
| 34 | NC | NC |
| 35 | LAN_PORT0_TX+ | Ethernet port |
| 36 | USB + | USB signal, carries USB data to and from the USB 2.0 PHY |
| 37 | LAN_PORT0_TX- | Ethernet port |
| 38 | USB - | USB signal, carries USB data to and from the USB 2.0 PHY |
| 39 | GND | Ground |
| 40 | SYSTEM_LED | System LED, GPIO#13 |

| | | |
|----|------------------------|--|
| 41 | VDD_2.0V OUTPUT | Power supply output for peripheral network transformer |
| 42 | VDD_2.5V OUTPUT | GPIO voltage output for LED |
| 43 | VDD_2.0V OUTPUT | Power supply output for peripheral network transformer |
| 44 | RESET | It has a internal 10k pull-up resistance, and trigger while Pulling down |
| 45 | GND | Ground |
| 46 | JUMPSTART (GPIO_17) | Resets the firmware to its default configuration, KEY_INPUT to start WPS function, it has a internal 10k pull-up resistance, and trigger |
| 47 | SPI_MISO | SPI serial interface |
| 48 | GND | Ground |
| 49 | SPI_CLK | SPI serial interface |
| 50 | VDD_3.3V | 3.3V input 1000mA, recommended voltage 3.3V, Min2.97V, MAX 3.63V |
| 51 | SPI_MOSI | SPI serial interface |
| 52 | VDD_3.3V | 3.3V input 1000mA, recommended voltage 3.3V, Min2.97V, MAX 3.63V |
| 53 | LED_LINK1 | Port #0 activity LED, GPIO#16 |
| 54 | LED_WAN | WAN LED, GPIO#4, do not pull up to VDD_3V3 |
| 55 | WLAN_LED | Wireless LED, GPIO#12 |
| 56 | NC | No Connect |
| 57 | UART_TX | Serial data out, GPIO#10 |
| 58 | UART_RX | Serial data in, GPIO#9 |
| 59 | GND | Ground |
| 60 | GND | Ground |

警告：GPIO4 不能被拉到 VDD_3V3。

WARNING: GPIO4 do not pull up to VDD_3V3.

8 PCB 封装和尺寸/ PCB Footprint and Dimensions

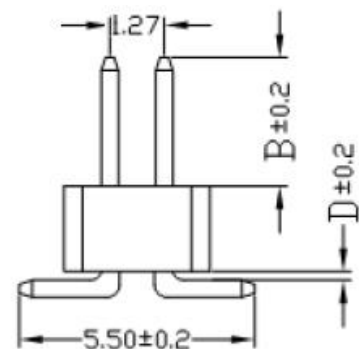
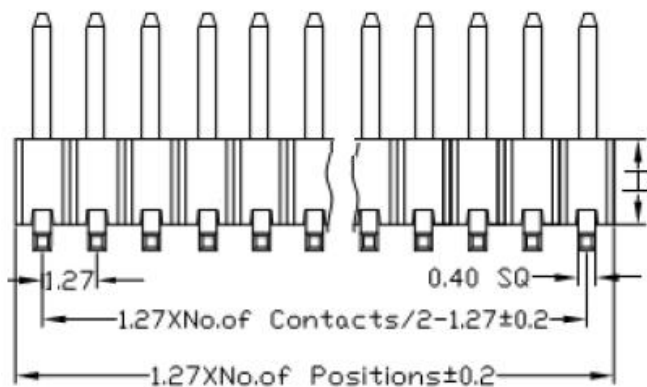
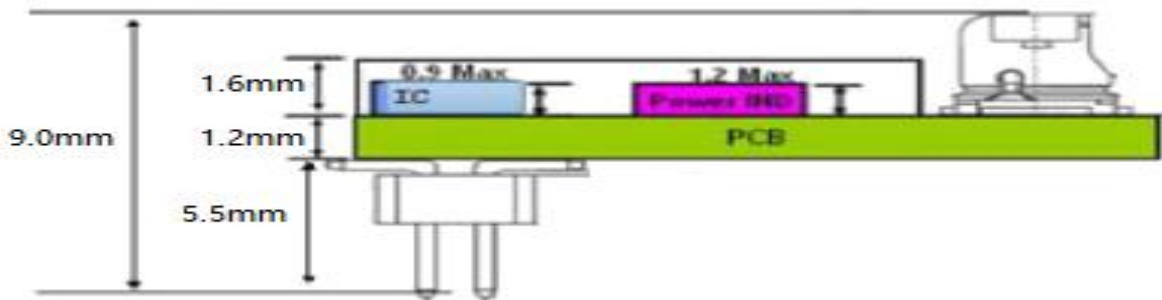
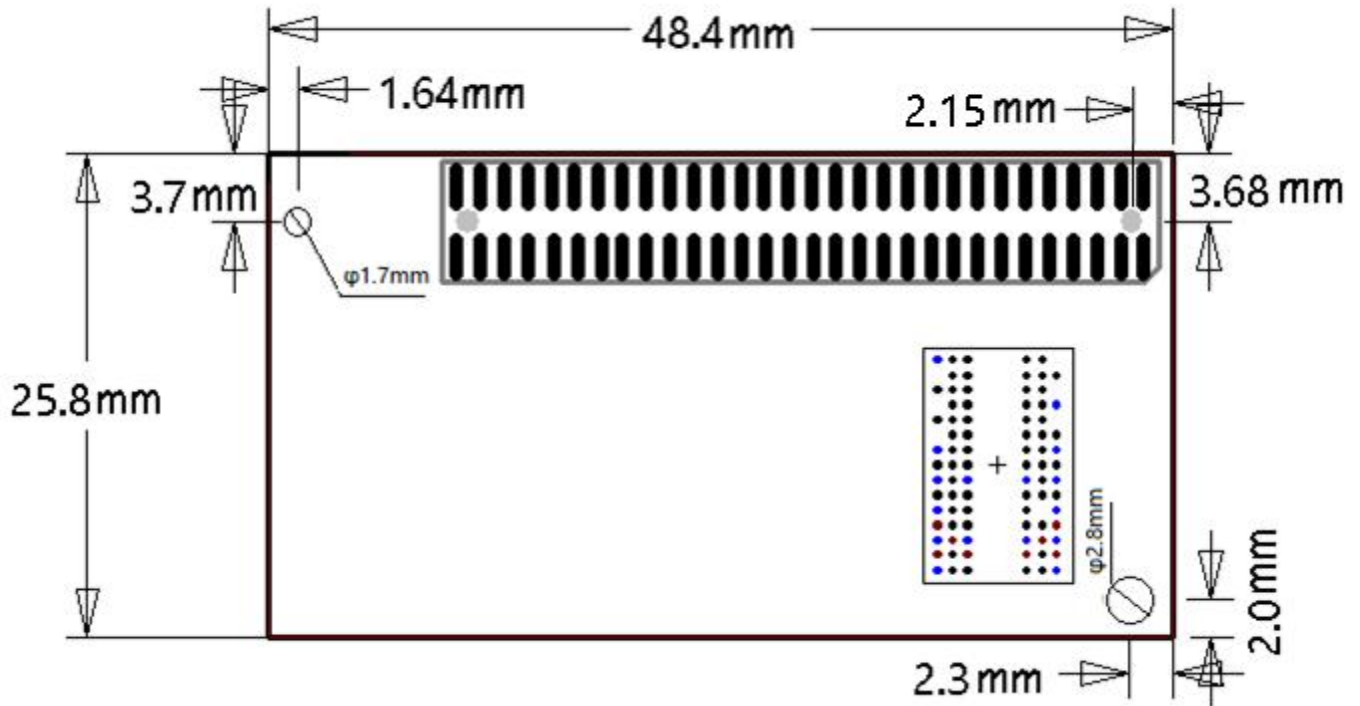

| Dimension antitheses list | | | |
|---------------------------|-----|-----|-----|
| ITEM | D | B | H |
| Standard | 0.4 | 4.0 | 1.0 |

Figure 4: SKW99 推荐 PCB 封装/ SKW99 Recommend PCB Footprint

9 电气特性 Electrical Characteristics

a) 绝对最大额定参数 Absolute Maximum Ratings

Table9-1: 绝对最大额定参数/ Absolute Maximum Ratings

| 参数/Parameter | 条件/Condition | 最小值 /Min | 典型值 Typ. | 最大值/Max. | 单位/ Unit |
|-----------------------------|--------------|-------------|-------------|----------|----------|
| 存储温度范围/Storage | | -40 | | 125 | °C |
| ESD 保护/ ESD Protection | VESD | / | | 2000 | V |
| 电源电压/ Supply voltage | VDD_3.3V | 0 | | 3.6 | V |
| I/O 脚电压/ Voltage on any I/O | | -0.3 | | 3.63 | V |



SKW99 系列模块是静电敏感设备，在处理时需要特殊的注意事项。

SKW99 series modules are Electrostatic Sensitive Devices and require special precautions while handling.

ESD 预防措施 ESD precautions

SKW99 模块包含高度敏感的电子电路，是静电敏感器件。处理 SKW99 模块时没有做好防静电保护，可能会导致 SKW99 模块永久损坏或毁坏它们。

The SKW99 module contain highly sensitive electronic circuitry and are Electrostatic Sensitive Devices (ESD).

Handling the SKW99 module without proper ESD protection may destroy or damage them permanently.

SKW99 模块属于静电敏感器件，需要针对静电敏感器件采取特殊的防静电措施。在包含 SKW99 模块的任何应用程序的整个加工、处理、运输和操作过程中，必须应用适当的防静电处理和包装程序。请勿用手触摸模块或使用非防静电烙铁焊接，以免损坏模块。

The SKW99 module are electrostatic sensitive devices (ESD) and require special ESD precautions typically applied to ESD sensitive components. Proper ESD handling and packaging procedures must be applied throughout the processing, handling, transportation and operation of any application that incorporates the SKW99 module. Don't touch the module by hand or solder with non-anti-static soldering iron to avoid damage to the module.

b) 推荐的工作条件 Recommended Operation Ratings

Table9-2: 工作条件/ Operating Conditions

| Parameter | Symbol | Minimum | Typical | Maximum | Unit |
|----------------------|----------|---------|---------|---------|------|
| Extended temp. range | TA | -20 | | 70 | °C |
| Power Supply | VDD_3.3V | 3.14 | 3.3 | 3.46 | V |
| Input Low Voltage | VIL | -0.3 | | 0.8 | V |
| Input High Voltage | VIH | 2 | | 3.63 | V |

c) 测量条件/ Measurement Conditions

Table9-3: 不同状态功耗/ Power Consumption in Different States

| 系统状态/ System state | 电流/Current (Typ.)@3.3V | 电流/Current (Max.)@3.3V |
|---|------------------------|------------------------|
| 待机/ Standby | 180mA | 210mA |
| Transmit (2.4g; +15dBm @ TX HT20 MCS7.) | 400mA | |
| Transmit (2.4g; +18dBm @ 11b 11Mbps.) | 580mA | 685mA |

10 包装规范 Packaging Specification

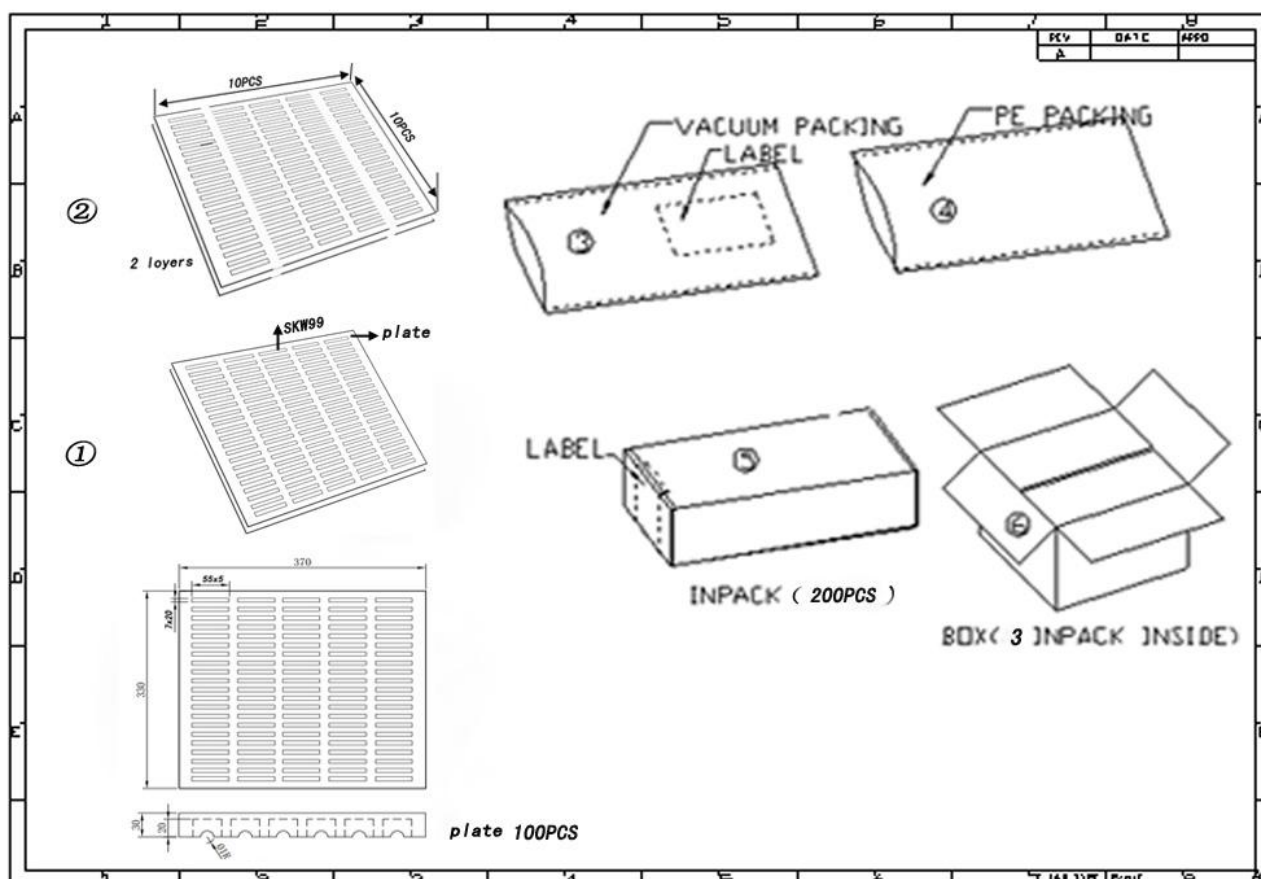

11 订购信息 Ordering Information

| 型号/Module No. | SPI Flash Size | DDR2 Size |
|---------------|----------------|-------------|
| SKW99_E85 | 8M Bytes | 512M bites |
| SKW99_E81 | 8M Bytes | 1024M bites |
| SKW99_E165 | 16M Bytes | 512M bites |
| SKW99_E161 | 16M Bytes | 1024M bites |
| SKW99_E325 | 32M Bytes | 512M bites |
| SKW99_E321 | 32M Bytes | 1024M bites |

12 联系信息 Contact Information

Skylab M&C Technology Co., Ltd.

深圳市天工测控技术有限公司

地址/ **Address:** 6 Floor, No.9 Building, Lijincheng Scientific & Technical park, Gongye East Road,
Longhua District, Shenzhen, Guangdong, China

电话/ **Phone:** 86-755 8340 8210 (Sales Support)

电话/ **Phone:** 86-755 8340 8510 (Technical Support)

传真/ **Fax:** 86-755-8340 8560

邮箱/ **E-Mail:** technicalsupport@skylab.com.cn

网址/ **Website:** www.skylab.com.cn www.skylabmodule.com